

ScanSnap S1500/S1500M Image Scanner Maintenance Manual



						TITLE	ScanSnap S1500/S1500-SR/S1500M MAINTENANCE MANUAL			
						DRAW. No.	P1PA03586-B00X/6		CUST.	
02	Jan. 23, 2009	K.Okada	T.Anzai	I.Fujioka	Refer to Revision Record on page 2.					
Rev	DATE	DESIG.	CHECK	APPR.	DESCRIPTION					
DESIG	Jan. 9, 2009	K.Okada	CHECK	T.Anzai		APPR.	I.Fujioka	PFU LIMITED	PAGE	1/140

Revision Record			
Edition	Date published	Revised contents	
		Pages	Contents
D01	November 28, 2008	Draft version released.	
01	January 9, 2009	First version released.	
02	January 23, 2009	17 (Section 1.6)	Multifeed Detection method and specification revised.

The contents of this manual are subject to change without prior notice.
 All rights Reserved. Copyright © PFU LIMITED, 2008-2009

						TITLE	ScanSnap S1500/S1500-SR/S1500M MAINTENANCE MANUAL	
						DRAW. No.	P1PA03586-B00X/6	CUST.
02	Jan. 23, 2009	K.Okada	T.Anzai	IFujioka	Refer to Revision Record on page 2.			
Rev	DATE	DESIG.	CHECK	APPR.	DESCRIPTION		PFU LIMITED	PAGE
DESIG	Jan. 9, 2009	K.Okada	CHECK	T.Anzai		APPR.		IFujioka

Preface

This manual provides the technical information such as maintenance, troubleshooting procedure and parts replacement procedure for Field Engineers on the ScanSnap S1500/S1500M Image Scanner.
This manual is not responsible if used for anything other than maintenance.

For information that is not contained in this manual, refer to the following manuals:

Item	Manuals	P/N	Remarks
1	ScanSnap S1500/S1500M Operator's Guide	P3PC-2432-xxENZO	Attached to the ScanSnap (DVD-ROM)
2	ScanSnap S1500/1500M Getting Started	P3PC-2412-xxEN	Attached to the ScanSnap (booklet)
3	Safety Precautions	P3PC-2452-xxEN	Attached to the ScanSnap (booklet)
4	S1500/S1500M Illustrated Parts Catalog	P4PA03586-B00X/6	---

* "xx" shows the revision number of the manuals.

Convention

Special information, such as warnings, cautions, are indicated as follows:

WARNING

This indication alerts operators to an operation that, if not strictly observed, may result in severe injury or death.

CAUTION

This indication alerts operators to an operation that, if not strictly observed, may result in safety hazards to personnel or damage to equipment.

NOTICE

NOTICE provides 'how-to' tips or suggestions to help you perform a procedure correctly.

						TITLE	ScanSnap S1500/S1500-SR/S1500M MAINTENANCE MANUAL				
						DRAW. No.	P1PA03586-B00X/6	CUST.			
02	Jan. 23, 2009	K.Okada	T.Anzai	IFujioka	Refer to Revision Record on page 2.						
Rev	DATE	DESIG.	CHECK	APPR.	DESCRIPTION						
DESIG	Jan. 9, 2009	K.Okada	CHECK	T.Anzai		APPR.	IFujioka	PFU LIMITED		PAGE	3/140

Trademarks

Microsoft, Windows, and Windows Vista are registered trademarks of Microsoft Corporation in the United States and/or other countries.

Apple, Apple logo, Mac and Mac OS are registered trademarks of Apple Inc.

ScanSnap and ScanSnap logo are the trademarks of PFU LIMITED.

Other product names are the trademarks or registered trademarks of the respective companies.

How Trademarks are Indicated in This Manual

The following abbreviated terms used in this manual are described.

Windows Vista: Microsoft® Windows Vista® Home Basic operating system, English Version
 Microsoft® Windows Vista® Home Premium operating system, English Version
 Microsoft® Windows Vista® Business operating system, English Version
 Microsoft® Windows Vista® Enterprise operating system, English Version
 Microsoft® Windows Vista® Ultimate operating system, English Version

Windows XP: Microsoft® Windows® XP Professional operating system, English Version

Microsoft® Windows® XP Home Edition operating system, English Version

Windows 2000: Microsoft® Windows® 2000 Professional operating system, English Version

Windows: Windows Vista, Windows XP, and Windows 2000

Mac OS: Mac OS X v10.5 and Mac OS X v10.4

S1500: Color Image Scanner ScanSnap S1500

S1500M: Color Image Scanner ScanSnap S1500M

ScanSnap: S1500 and S1500M

						TITLE	ScanSnap S1500/S1500-SR/S1500M MAINTENANCE MANUAL		
						DRAW. No.	P1PA03586-B00X/6	CUST.	
02	Jan. 23, 2009	K.Okada	T.Anzai	IFujioka	Refer to Revision Record on page 2.				
Rev	DATE	DESIG.	CHECK	APPR.	DESCRIPTION	PFU LIMITED		PAGE	4/140
DESIG	Jan. 9, 2009	K.Okada	CHECK	T.Anzai		APPR.	IFujioka		

Contents

Chapter 1 Overview	8
1.1 ScanSnap Overview	8
1.1.1 Features	8
1.1.2 Product List.....	8
1.1.3 ScanSnap Specifications	9
1.1.4 Environmental Specifications.....	10
1.1.5 Appearance	11
1.2 Document Specification.....	13
1.2.1 Without Using the Carrier Sheet	13
1.2.2 With Using the Carrier Sheet.....	14
1.3 ADF Unit.....	15
1.3.1 ADF.....	15
1.3.2 Paper Separation.....	15
1.3.3 Drive Unit	15
1.4 Reading Section	16
1.5 Controller.....	17
1.5.1 Control PCA	17
1.5.2 Analog PCA.....	17
1.5.3 Panel PCA.....	17
1.6 Multifeed Detection Condition	17
1.7 Circuit Block Diagram.....	18
1.8 Consumables	18
Chapter 2 Installation	19
2.1 Unpacking the ScanSnap.....	19
2.2 Installing the ScanSnap	19
2.2.1 For Safety Installation.....	19
2.2.2 Installation	20
Chapter 3 Maintenance Parts.....	21
3.1 Maintenance Parts List	21
3.2 Maintenance Parts Specifications / Appearance	22
3.2.1 Revolve Unit.....	22
3.2.2 Lamp	22
3.2.3 Inverter.....	23
3.2.4 Optical Unit	23
3.2.5 Panel PCA.....	24
3.2.6 US Sensor RV.....	24
3.2.7 Sensor ASSY B3	25
3.2.8 Top Cover ASSY.....	25
3.2.9 Fixed Unit	26
3.2.10 Fix Sub Unit.....	26
3.2.11 Motor.....	27
3.2.12 Pick Shaft ASSY	27
3.2.13 US Sensor F.....	27
3.2.14 Feed Roller.....	28
3.2.15 Exit Roller.....	28
3.2.16 Control PCA	29
3.2.17 Analog PCA.....	29
3.2.18 Guide P ASSY	29
3.2.19 LIDCOV ASSY.....	30
3.2.20 Torque-Dumper	30
3.2.21 Guide A.....	31

						TITLE	ScanSnap S1500/S1500-SR/S1500M MAINTENANCE MANUAL			
						DRAW. No.	P1PA03586-B00X/6		CUST.	
02	Jan. 23, 2009	K.Okada	T.Anzai	I.Fujioka	Refer to Revision Record on page 2.					
Rev	DATE	DESIG.	CHECK	APPR.	DESCRIPTION				PAGE	5/140
DESIG	Jan. 9, 2009	K.Okada	CHECK	T.Anzai	APPR.	PFU LIMITED		PAGE	5/140	
						I.Fujioka				

3.2.22 Chute ASSY 31
 3.2.23 Stacker ASSY 32
 3.2.24 AC Adapter 32
 3.2.25 AC Cables 33
 3.2.26 USB Cable 33
 3.2.27 ~ 30 (Reserved) 33
 3.2.31 HK Ring 33

Chapter 4 Troubleshooting 34

4.1 Error Detection Algorithm 34
 4.2 Temporary Error Detection Algorithm..... 35
 4.3 Alarm Detection Algorithm 36
 4.4 Troubleshooting 38
 4.4.1 Scanner does not Turn ON (No LED blinking on the operator Panel) 39
 4.4.2 Scanning Does not Start..... 40
 4.4.3 Scanned Image is Distorted 41
 4.4.4 Too Much Jitter on Scanned Image when Scanning from the ADF 42
 4.4.5 Offset or Image Size is incorrect..... 43
 4.4.6 Vertical Streaks Appear in Scanned Image 44
 4.4.7 Frequent Document Jam Error 44
 4.4.8 No Paper on the ADF Paper Chute 45
 4.4.9 ADF Cover Open..... 45
 4.4.10 Multi Feed..... 46
 4.4.11 Optical Alarm (ADF Front Side or ADF Back Side)..... 46
 4.4.12 Motor Fuse Blown..... 47
 4.4.13 Operator Panel Alarm 47
 4.4.14 EEPROM Alarm..... 47
 4.4.15 Image Memory Alarm, RAM Alarm, USB Control Chip Alarm..... 47
 4.4.16 Data Transfer Error Occurred..... 47
 4.4.17 US Sensor Alarm..... 48

Chapter 5 Maintenance Procedure..... 49

5.1 For Safety Operation..... 49
 5.2 Preventive Maintenance 49
 5.3 Cleaning Maintenance Parts..... 50
 5.3.1 Optical Unit 50
 5.4 Maintenance Tool 51
 5.5 Non-disassembly Parts 52
 5.6 Replacing LIDCOV ASSY / Guide P ASSY / Stacker ASSY / Chute ASSY..... 53
 5.6.1 LIDCOV ASSY..... 53
 5.6.2 Guide P ASSY 54
 5.6.3 Stacker ASSY..... 55
 5.6.4 Chute ASSY..... 56
 5.7 Replacing Control PCA / Analog PCA 57
 5.8 Replacing Guide A..... 59
 5.9 Removing Base Cover ASSY and Replacing Torque-Dumper 60
 5.10 Replacing the Parts inside of Fixed Unit..... 62
 5.10.1 Exit Roller / HK Ring 62
 5.10.2 Optical Unit (for front side scanning) 64
 5.10.3 Motor..... 67
 5.10.4 Lamp (for front side scanning) 69
 5.10.5 Inverter (for front side scanning)..... 72
 5.10.6 Pick Shaft ASSY 73
 5.10.7 US Sensor F 74
 5.10.8 Feed Roller..... 75
 5.10.9 Fix Sub Unit..... 79
 5.11 Replacing the Parts inside of Revolve Unit 80

						TITLE	ScanSnap S1500/S1500-SR/S1500M MAINTENANCE MANUAL			
						DRAW. No.	P1PA03586-B00X/6	CUST.		
02	Jan. 23, 2009	K.Okada	T.Anzai	IFujioka	Refer to Revision Record on page 2.					
Rev	DATE	DESIG.	CHECK	APPR.	DESCRIPTION			PFU LIMITED	PAGE	6/140
DESIG	Jan. 9, 2009	K.Okada	CHECK	T.Anzai		APPR.	IFujioka			

5.11.1 Top Cover ASSY 80

5.11.2 Panel PCA..... 81

5.11.3 Optical Unit (for backside scanning) 82

5.11.4 Lamp (for backside scanning) 83

5.11.5 Inverter (for backside scanning)..... 86

5.11.6 Sensor ASSY B3 87

5.11.7 US Sensor RV..... 95

5.12 Replacing the Fixed Unit / Revolve Unit..... 96

5.13 Adjusting Belt Tension..... 99

 5.13.1 Adjusting Belt A..... 100

 5.13.2 Adjusting Belt B..... 101

5.14 Notes on Installing the Cables and Clamps..... 102

 5.14.1 Wiring the Shield Plate Section and Clamps..... 102

 5.14.2 Wiring Cables at PCB-UNIT Section 106

Chapter 6 Test Program..... 108

6.1 System Environment of Test Program..... 108

6.2 Work Flow of Unit Inspection and Unit Repair..... 109

6.3 How to Save EEPROM Data 110

6.4 How to Restore the EEPROM Data..... 113

6.5 How to Refer to the EEPROM Data..... 115

6.6 How to Use the TP-TOWER..... 117

Chapter 7 Operation and Daily Maintenance..... 124

7.1 Basic Operation..... 124

 7.1.1 Power ON/OFF..... 124

 7.1.2 Opening/Closing the ADF 125

 7.1.3 Loading Documents 126

7.2. Daily Care 129

 7.2.1 Cleaning Materials 129

 7.2.2 Cleaning the ScanSnap Exterior..... 129

 7.2.3 Cleaning the Inside of the ScanSnap..... 130

 7.2.4 Cleaning Carrier Sheet 132

7.3 Consumables and Replacement 133

 7.3.1 Consumables..... 133

 7.3.2 Confirming and Resetting the Consumable Counter [Windows]..... 134

 7.3.3 Confirming and Resetting the Consumable Counter [Mac] 135

 7.3.4 Replacing the Pick Roller 136

 7.3.5 Replacing the Pad ASSY 140

						TITLE	ScanSnap S1500/S1500-SR/S1500M MAINTENANCE MANUAL			
						DRAW. No.	P1PA03586-B00X/6	CUST.		
02	Jan. 23, 2009	K.Okada	T.Anzai	IFujioka	Refer to Revision Record on page 2.					
Rev	DATE	DESIG.	CHECK	APPR.	DESCRIPTION			PFU LIMITED	PAGE	7/140
DESIG	Jan. 9, 2009	K.Okada	CHECK	T.Anzai		APPR.	IFujioka			

Chapter 1 Overview

1.1 ScanSnap Overview

The ScanSnap S1500/S1500M, image scanner offers color/monochrome scanning of various size documents with 600dpi optical resolution. This scanner has a USB 2.0 interface and image input is available via the included exclusive driver.



1.1.1 Features

This section describes the functions of the ScanSnap S1500/S1500M.

- Document conversion
Converts documents into PDF files or JPEG files to make users display, edit administrate, and save the files on the PC. You do not need to configure the color mode for each document as the ScanSnap scans document by automatically discriminate color/gray/black-and-white.
- Accurate scanning speed
Duplex-scans 20 sheets of A4 color documents per minute. (When “Scan mode: Auto”, “Color mode: Auto” “Compression ratio: 3” and other settings are default)
But the scanning speed of documents in black-and-white mode may deteriorate (because the image scanned as color is converted into black and white).
- Small footprint
The ScanSnap is smaller than A4-size documents. You can place it on your desk.
- Easy operation (Quick Menu)
When the **Scan** button is pressed, documents are scanned, and then Quick Menu appears. All you have to do is to select a desired operation (when Quick Menu is being used).

1.1.2 Product List

<Scanner>

Items	Remarks
ScanSnap S1500	Exclusive for Windows
ScanSnap S1500M	Exclusive for Mac

						TITLE	ScanSnap S1500/S1500-SR/S1500M MAINTENANCE MANUAL			
						DRAW. No.	P1PA03586-B00X/6	CUST.		
02	Jan. 23, 2009	K.Okada	T.Anzai	IFujioka	Refer to Revision Record on page 2.					
Rev	DATE	DESIG.	CHECK	APPR.	DESCRIPTION			PFU LIMITED	PAGE	8/140
DESIG	Jan. 9, 2009	K.Okada	CHECK	T.Anzai		APPR.	IFujioka			

1.1.3 ScanSnap Specifications

No.	Items	Specifications		
1	Scanning method	Color CCD (Charge-coupled device) x 2		
2	Operating method	Sheet Feeder (ADF), Duplex scan		
3	Scan mode	Color		
4	Light source	White-cold cathode discharge lamp (both front and back, two tubes per scanner)		
5	Optical resolution	600 dpi x 600 dpi (main scanning x sub-scanning)		
6	Output resolution	Monochrome	Equivalent to 300, 400, 600, 1200 dpi	
		Gray	150, 200, 300, 600 dpi	
		Color	150, 200, 300, 600 dpi	
7	Document size		Width	Length
		Minimum	50.8 mm (2 in.)	50.8mm (2 in.)
		Maximum	216 mm (8.5 in.)	355.6 mm (14 in.)
		Long page scanning: 216 x 863 mm (8.5 x 34 inch) at maximum		
8	ADF capacity	50 sheets (80g/m ² , 20 lb)		
9	Paper weight	52 to 127 g/m ² (14 to 34 lb.)		
10	Sheet setting	Front side down (Default), Front side up (by driver setting-S1500 only)		
11	File format	PDF, High Compression PDF, JPEG (Color / Gray)		
12	Background color	White		
13	Stacker	Retractable		
14	Interface	USB 2.0 B-Type x 1 (Rear side) (*1)		
15	Image processing function	Deskew, Auto-cropping, Auto orientation, Blank page deletion		
16	Scanning speed (transfer time excluded) (*2)	Scan mode/Resolution		Process speed
		Auto mode (*3)	Fine or Super fine	20 sheets / min.
			Normal	Color / Gray (150 dpi)
		Fine mode		B/W (equivalent to 300 dpi)
			Super fine mode	Color / Gray (200 dpi)
		Excellent mode		B/W (equivalent to 400 dpi)
			B/W (equivalent to 600 dpi)	Color / Gray (300 dpi)
		B/W (equivalent to 1200 dpi)		B/W (equivalent to 600 dpi)
			Color / Gray (600 dpi)	
		B/W (equivalent to 1200 dpi)		5 sheets / min.

*1: USB 1.1 is also supported.

*2: A4 Portrait

*3: Fine/Superfine is switched depending on page length in Auto mode.

						TITLE	ScanSnap S1500/S1500-SR/S1500M MAINTENANCE MANUAL			
						DRAW. No.	P1PA03586-B00X/6		CUST.	
02	Jan. 23, 2009	K.Okada	T.Anzai	IFujioka	Refer to Revision Record on page 2.					
Rev	DATE	DESIG.	CHECK	APPR.	DESCRIPTION				PAGE	9/140
DESIG	Jan. 9, 2009	K.Okada	CHECK	T.Anzai		APPR.	IFujioka	PFU LIMITED		

1.1.4 Environmental Specifications

No.	Items		Specifications
1	Dimensions (*2)	Minimum	292 (W) x 159 (D) x 158 (H) mm (11.5 (W) x 6.3 (D) x 6.2 (H) inches)
		Maximum	292 (W) x 475 (D) x 286 (H) mm (11.5 (W) x 18.7 (D) x 11.3 (H) inches)
2	Weight		3.0 kg (6.62 lb) or less
3	Input power		AC adapter: AC 100V~240V ± 10% (*1) Frequency: 50/60Hz
4	Power consumption	During operation	35 W or less
		Not operating	4.5 W or less (During standby)
5	Ambient temperature		During operation: 5~35°C (41~95°F), During standby: -20~60°C (-4~140°F), During storage/transportation: -20~60°C (-4~140°F)
6	Ambient humidity		During operation: 20~80% During standby: 8~95% During storage/transportation: 8~95%

*1: Input power to AC adapter

*2: Overall size

[Minimum (Chute ASSY and Stacker stored)]

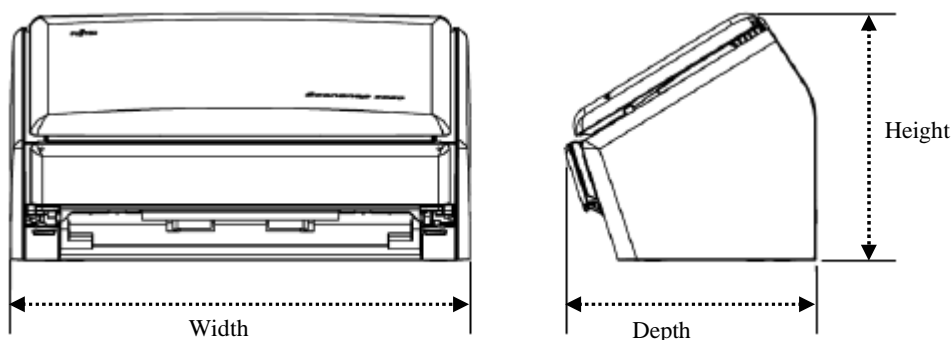

[Maximum (Chute ASSY and Stacker opened)]

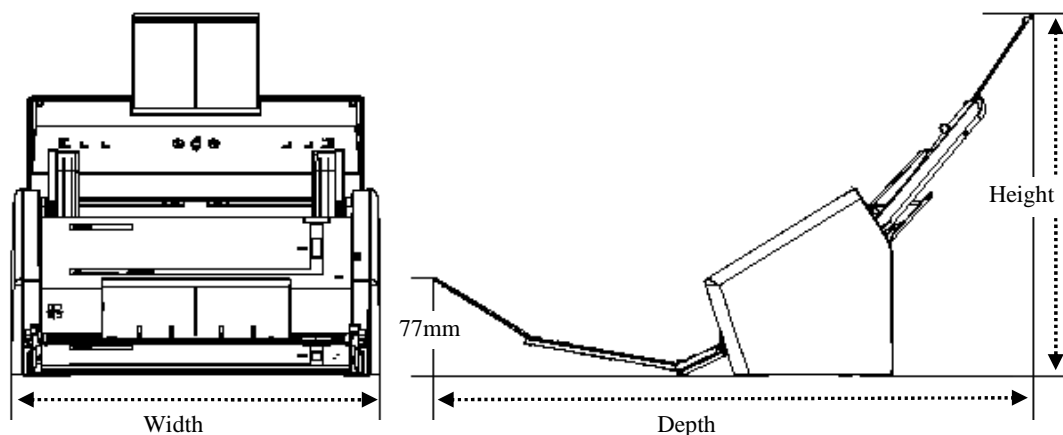

						TITLE	ScanSnap S1500/S1500-SR/S1500M MAINTENANCE MANUAL				
						DRAW. No.	P1PA03586-B00X/6		CUST.		
02	Jan. 23, 2009	K.Okada	T.Anzai	IFujioka	Refer to Revision Record on page 2.						
Rev	DATE	DESIG.	CHECK	APPR.	DESCRIPTION				PFU LIMITED	PAGE	10/140
DESIG	Jan. 9, 2009	K.Okada	CHECK	T.Anzai		APPR.	IFujioka				

1.1.5 Appearance

< Front of the ScanSnap >

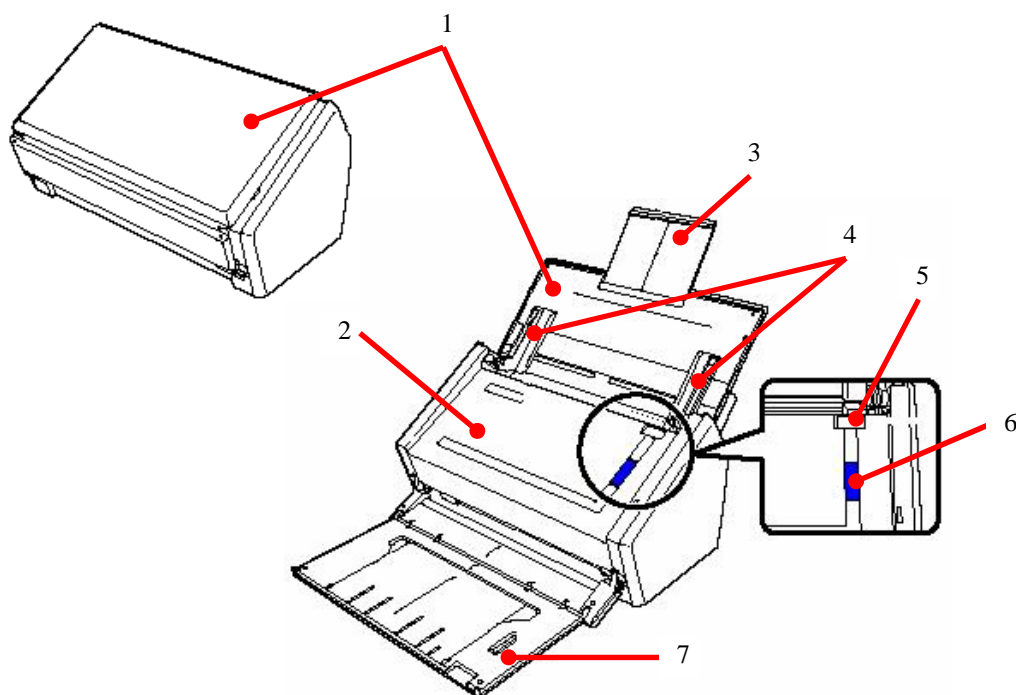

No.	Parts name	Function
1	ADF Paper chute (Chute ASSY)	Open this cover before using the ScanSnap. Opening the cover turns on the power. Load the document here.
2	ADF Top Section	Open when removing the jammed documents, replacing the Pad ASSY or Pick Roller, and cleaning inside of the ScanSnap.
3	Extension	Extend the Extension when scanning the long documents.
4	Side guide	Adjust the Side Guides to the width of documents to prevent scanned images from being skewed.
5	ADF Release Catch	To open the ADF, pull this lever toward you.
6	[Scan] Button / Power Indicator	<ul style="list-style-type: none"> - Indicates scanner status (Power ON/OFF, abnormal) - Scans the documents loaded on the ScanSnap. - Pressing this button (for 3 seconds or over) switches to long page scanning mode (Blue LED flashing). [Indicator and Status] Power ON: Blue lighting During scanning: Blue flashing Abnormal status: Orange flashing
7	Stacker	Open the Stacker to load the ejected documents here.

						TITLE	ScanSnap S1500/S1500-SR/S1500M MAINTENANCE MANUAL		
						DRAW. No.	P1PA03586-B00X/6	CUST.	
02	Jan. 23, 2009	K.Okada	T.Anzai	IFujioka	Refer to Revision Record on page 2.				
Rev	DATE	DESIG.	CHECK	APPR.	DESCRIPTION	PFU LIMITED		PAGE	11/140
DESIG	Jan. 9, 2009	K.Okada	CHECK	T.Anzai	APPR.	IFujioka			

<Rear of the ScanSnap>

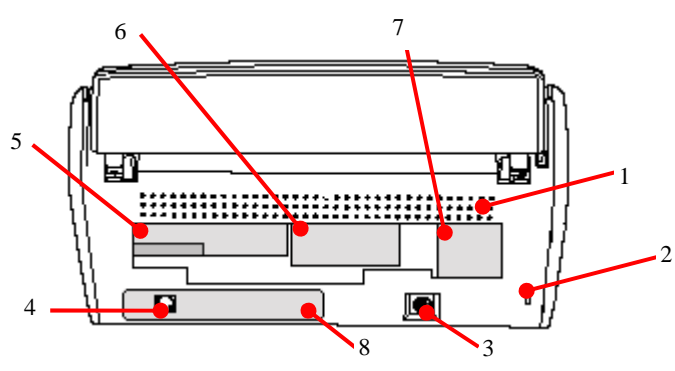

No.	Parts name	Function
1	Ventilation ports	These openings ventilate the interior of the ScanSnap.
2	Security cable slot	Insert a commercially available security cable into this slot (anti-theft).
3	Power connector	Connects the Power cable.
4	USB connector	Connects the USB interface cable from the host system.
5	Manufacturing label	
6	Specification label	
7	Book label	
8	USB label (Tape seal)	<p>After installing the software, remove this tape seal.</p>

						TITLE	ScanSnap S1500/S1500-SR/S1500M MAINTENANCE MANUAL		
						DRAW. No.	P1PA03586-B00X/6		CUST.
02	Jan. 23, 2009	K.Okada	T.Anzai	IFujioka	Refer to Revision Record on page 2.				
Rev	DATE	DESIG.	CHECK	APPR.	DESCRIPTION		PFU LIMITED		PAGE 12/140
DESIG	Jan. 9, 2009	K.Okada	CHECK	T.Anzai		APPR.	IFujioka		

1.2 Document Specification

Paper sizes of documents to be scanned are as follows:

1.2.1 Without Using the Carrier Sheet

Paper type	Standard office paper, post cards, business cards
Weight	52 ~ 127g/m ² (14 ~ 34 lb)
Size	Width: 50.8 ~ 216mm (2 ~ 8.5 in.) Length: 50.8 ~ 360mm (2 ~ 14.17 in.) Maximum of long page scanning (*1) 216 x 863mm (8.5 x 34 in.)

*1: Long page scanning is available only when the [Scan] button is pressed for three seconds. If “Excellent” is selected for image quality, long page document scanning is not available.

Note 1: Do not scan the following types of documents:

- Documents with paper clips or staples (Remove clips and staples to scan these documents.)
- Documents before ink dries (Scan the documents after the ink dries)
- Documents larger than 216 x 863 mm (8.5 x 34 in.)
- Materials other than paper such as fabric, metal foil, or transparencies, or plastic card

Note 2: Scanning the following types of documents without using the Carrier Sheet can result in the documents being damaged or scanned incorrectly. It is recommended that you use the Carrier Sheet.

- Documents smaller than 50.8 x 50.8 mm (2 x 2 in.)
- Documents thinner than 52 g/m² (14 lb)
- Documents of non-uniform thickness (e.g. envelopes and paper sheets with other paper sheets affixed)
- Wrinkled or curled documents
- Documents written with a pencil
- Folded or torn documents
- Tracing paper
- Coated paper
- Photographs (printing paper)
- Perforated or punched documents
- Documents of not-square (or not-rectangular) shaped paper
- Documents including different widths
- Carbonless paper
- Carbon paper or thermal paper
- Documents with photographs or sticky notes affixed.

Allowable curling range

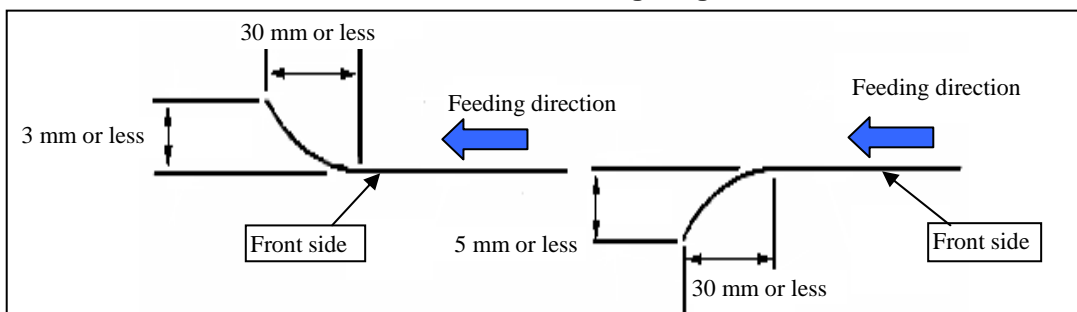

						TITLE	ScanSnap S1500/S1500-SR/S1500M MAINTENANCE MANUAL		
						DRAW. No.	P1PA03586-B00X/6	CUST.	
02	Jan. 23, 2009	K.Okada	T.Anzai	IFujioka	Refer to Revision Record on page 2.				
Rev	DATE	DESIG.	CHECK	APPR.	DESCRIPTION				
DESIG	Jan. 9, 2009	K.Okada	CHECK	T.Anzai		APPR.	IFujioka	PFU LIMITED	PAGE 13/140

1.2.2 With Using the Carrier Sheet

Paper type	Standard office paper, post cards, business cards, photographs, clipping
Weight	Up to 127g/m ² (Up to 34 lb) Up to 63.5 g/m ² (Up to 17 lb) *when scanning paper folded in half
Size	Carrier Sheet Size (216 × 297 mm) Letter (8.5 × 11 in (216 × 279.4 mm)) 11 × 17 in (279.4 × 431.8 mm) (*) A3 (297 × 420 mm) (*) A4 (210 × 297 mm) A5 (148 × 210 mm) A6 (105 × 148 mm) B4 (JIS) (257 × 364 mm) (*) B5 (JIS) (182 × 257 mm) B6 (JIS) (128 × 182 mm) Post card (100 × 148 mm) Business card (90 × 55 mm, 55 × 90 mm) Custom Width: 50.8 to 216 mm (2 to 8.5 in) Length: 50.8 to 297 mm (2 to 11.69 in)

* Fold in half when scanning.

Notes when using the Carrier Sheet

- Do not write on, color, stain, or cut the portion striped in black and white on the Carrier Sheet. Doing so may prevent the document from being correctly scanned with the Carrier Sheet.
- Do not place the Carrier Sheet upside-down on the ScanSnap. Doing so can cause a paper jam, or damage the Carrier Sheet.
- Do not leave a document on the Carrier Sheet for an extended period of time. The ink on the document might be transferred onto the Carrier Sheet.
- Do not leave the Carrier Sheet in locations that are exposed to elevated temperatures; for example, locations exposed to direct sunlight or near a heating apparatus, for an extended period of time. Do not use the Carrier Sheet under high-temperature conditions. If used under such a condition, it may be deformed.
- Do not bend or forcefully pull the Carrier Sheet.
- Do not use a damaged Carrier Sheet. Doing so can damage the ScanSnap or cause a malfunction.
- To avoid deformation of the Carrier Sheet, do not put anything heavy on it and keep it on a level surface when not in use.
- Be careful not to cut your fingers when touching the edge of the Carrier Sheet.
- Do not insert more than one small-size material such as pictures and post cards in the Carrier Sheet per scan. Doing so can cause a paper jam. It is recommended to scan small-size materials one at a time.
- If a paper jam occurs frequently, feed about 50 sheets of Plain Paper Copier (PPC) or recycled paper, and then scan the document by using the Carrier Sheet. You can use either unused or used PPC/recycled paper.

						TITLE	ScanSnap S1500/S1500-SR/S1500M MAINTENANCE MANUAL				
						DRAW. No.	P1PA03586-B00X/6		CUST.		
02	Jan. 23, 2009	K.Okada	T.Anzai	IFujioka	Refer to Revision Record on page 2.						
Rev	DATE	DESIG.	CHECK	APPR.	DESCRIPTION				PFU LIMITED	PAGE	14/140
DESIG	Jan. 9, 2009	K.Okada	CHECK	T.Anzai		APPR.	IFujioka				

1.3 ADF Unit

1.3.1 ADF

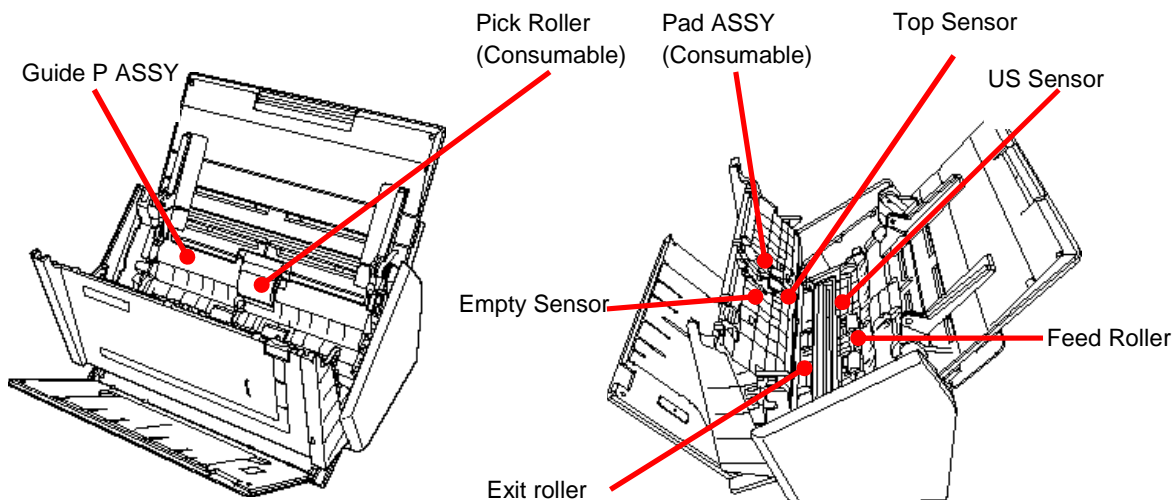

1.3.2 Paper Separation

Documents that are set on the ADF Paper chute are separated respectively by the Pick Roller and the Pad ASSY. The Top sensor detects the leading edge of the sheet and also detects paper jams. The documents are transported by the Feed roller at the speed that corresponds to the specified scanning resolution until they are stacked on the stacker by the Exit roller. The Empty sensor, Top sensor, Chute open sensor and Cover open sensor are installed in the ScanSnap.

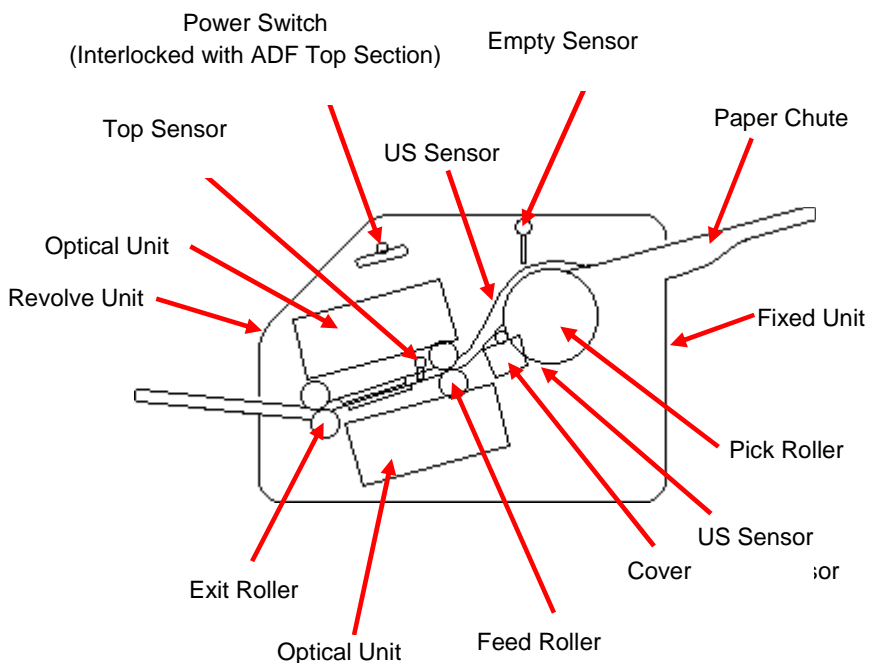

1.3.3 Drive Unit

The Pick roller, Feed roller and Exit roller are driven by the Feed motor. The ADF drive circuit and the motor fuse are located in the Analog PCA. If abnormal electric current runs through the ADF drive circuit, the current is cut off by the motor fuse in the Control PCA.

						TITLE	ScanSnap S1500/S1500-SR/S1500M MAINTENANCE MANUAL			
						DRAW. No.	P1PA03586-B00X/6	CUST.		
02	Jan. 23, 2009	K.Okada	T.Anzai	IFujioka	Refer to Revision Record on page 2.					
Rev	DATE	DESIG.	CHECK	APPR.	DESCRIPTION					
DESIG	Jan. 9, 2009	K.Okada	CHECK	T.Anzai	APPR. IFujioka			PFU LIMITED	PAGE	15/140

1.4 Reading Section

(1) Optical system

Documents are set in the ADF Paper chute, with front side face down. The front side of the document is read by the Optical Unit in the Fixed Unit, and the backside of the document is read by the Optical Unit in the Revolve Unit. These two Optical Units are identical (same part number).

The image on the document is projected to the color CCD through a lens and mirror system, and converted into image signals that are 10 bit per pixel at 600 dpi resolution.

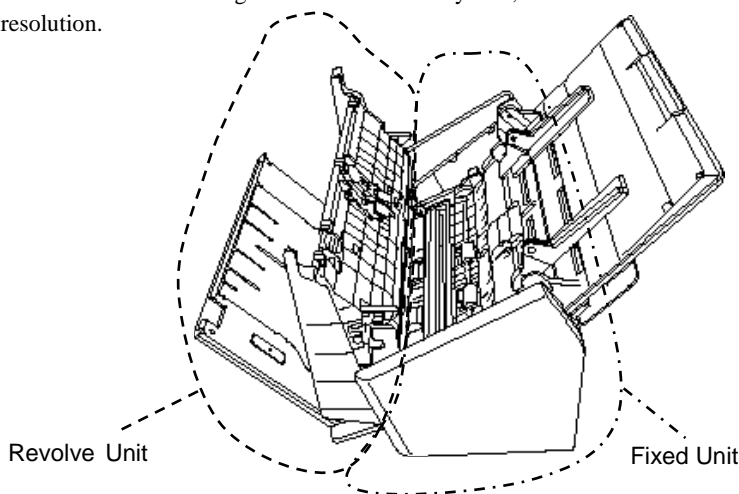

(2) Light source

The ScanSnap uses Lamps (white cold-cathode discharge lamp) that illuminate the areas of the document scanned by the Optical Units in order to get sufficient output. The lamp is turned ON/OFF by the Inverter that is controlled by the Control PCA.

(3) Scan controller

Before scanning a document, the ScanSnap reads the white background at the scanning section and adjusts the gain of the CCD amplifier. If the CCD output does not reach a reference level after the gain adjustment, an Optical alarm is issued.

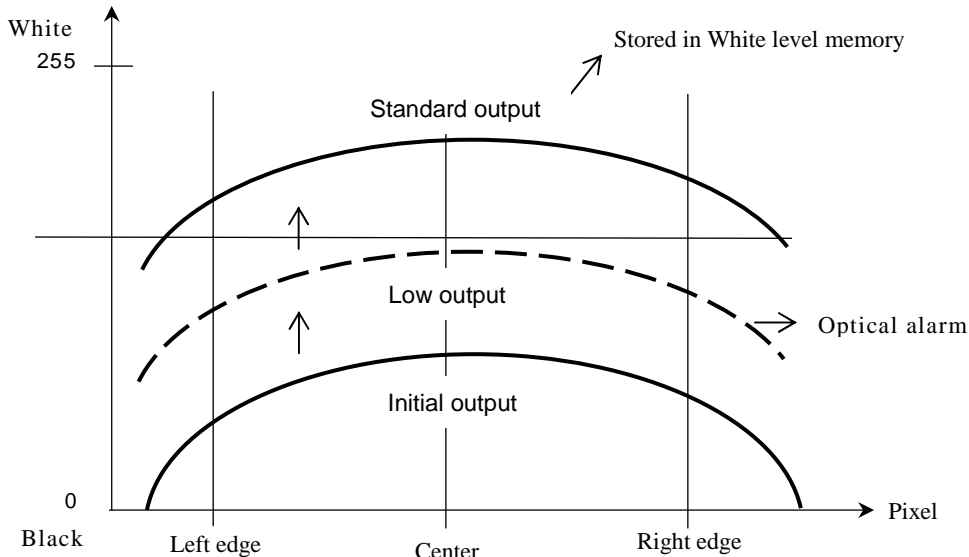

Figure 1.4 AGC (Automatic Gain Control)

When the gain adjustment is completed successfully, the ScanSnap feeds the document to the reading position at the speed that corresponds to the specified scanning resolution. The leading edge of the document is detected by the Top sensor in front of the scanning section. When the document is fed from the Top sensor by some defined length for front and back side scanning (the length which determines sub-scanning offset), the scanning image starts.

						TITLE	ScanSnap S1500/S1500-SR/S1500M MAINTENANCE MANUAL				
						DRAW. No.	P1PA03586-B00X/6	CUST.			
02	Jan. 23, 2009	K.Okada	T.Anzai	I.Fujioka	Refer to Revision Record on page 2.						
Rev	DATE	DESIG.	CHECK	APPR.	DESCRIPTION				PFU LIMITED	PAGE	16/140
DESIG	Jan. 9, 2009	K.Okada	CHECK	T.Anzai	APPR.	I.Fujioka					

1.5 Controller

1.5.1 Control PCA

The Control PCA controls units by the firmware.

The Control PCA includes the following connectors. (Refer to in Section 1.1.5 <Rear of the ScanSnap>)

- USB connector (one)
- DC voltage input connector

The firmware can be updated via USB interface from the PC.

1.5.2 Analog PCA

The Analog PCA includes a mechanical control circuit and a motor drive circuit such as fuses.

1.5.3 Panel PCA

The Panel PCA on the operator panel includes EEPROM that records the information below. When replacing the Panel PCA, you need to move all the data stored in the EEPROM to the Control PCA temporarily, and then restore the data from the Control PCA to the new Panel PCA (maintenance part). Refer to Sections 6.3 and 6.4 for details.

- Offset correction value for ADF main/sub-scanning direction
- Offset correction value for ADF back main/sub-scanning direction
- Thermistor temperature value
- Scanned sheets counter
- Duplex scanned sheets counter
- ADF consumables (Pad counter / Pick roller) counter
- First date of the scanner operation
- Shipping date
- Error codes in the past
- Serial number

1.6 Multifeed Detection Condition

02

One of the following two methods of multi feed detection is selected by ScanSnap Manager.

The following condition is required for each selection:

1) Check overlapping

- Paper weight: 0.065 ~ 0.15 mm thick, 52 ~ 127 g/m² (14 ~ 34 lb)
- Punched holes are not allowed within 50 mm (2.0 in) of the vertical centerline of the document.
- Other paper shall not be glued within 50 mm (2.0 in) of the vertical centerline of the document.

Note: When the overlapping check is specified, the paper which contacts closely each other, such as glued paper or electro-statically charged paper, may result in the miss-detection of multi feed.

2) Check length

- Document length deviation: 1 % or less
(only when the document size is specified)
- Punched holes are not allowed within 35 mm (1.4 in) of the vertical centerline of the document.

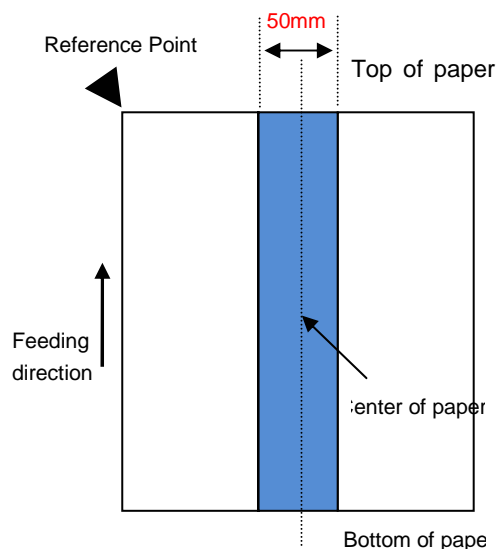

Note: The sensor exists in the center. If there is a hole at 35mm including the center line, multifeed may not be detected. If the rollers are slipped, multifeed is detected even though no multifeed actually occurs.

						TITLE	ScanSnap S1500/S1500-SR/S1500M MAINTENANCE MANUAL		
						DRAW. No.	P1PA03586-B00X/6	CUST.	
02	Jan. 23, 2009	K.Okada	T.Anzai	IFujioka	Refer to Revision Record on page 2.				
Rev	DATE	DESIG.	CHECK	APPR.	DESCRIPTION			PFU LIMITED	PAGE 17/140
DESIG	Jan. 9, 2009	K.Okada	CHECK	T.Anzai		APPR.	IFujioka		

1.7 Circuit Block Diagram

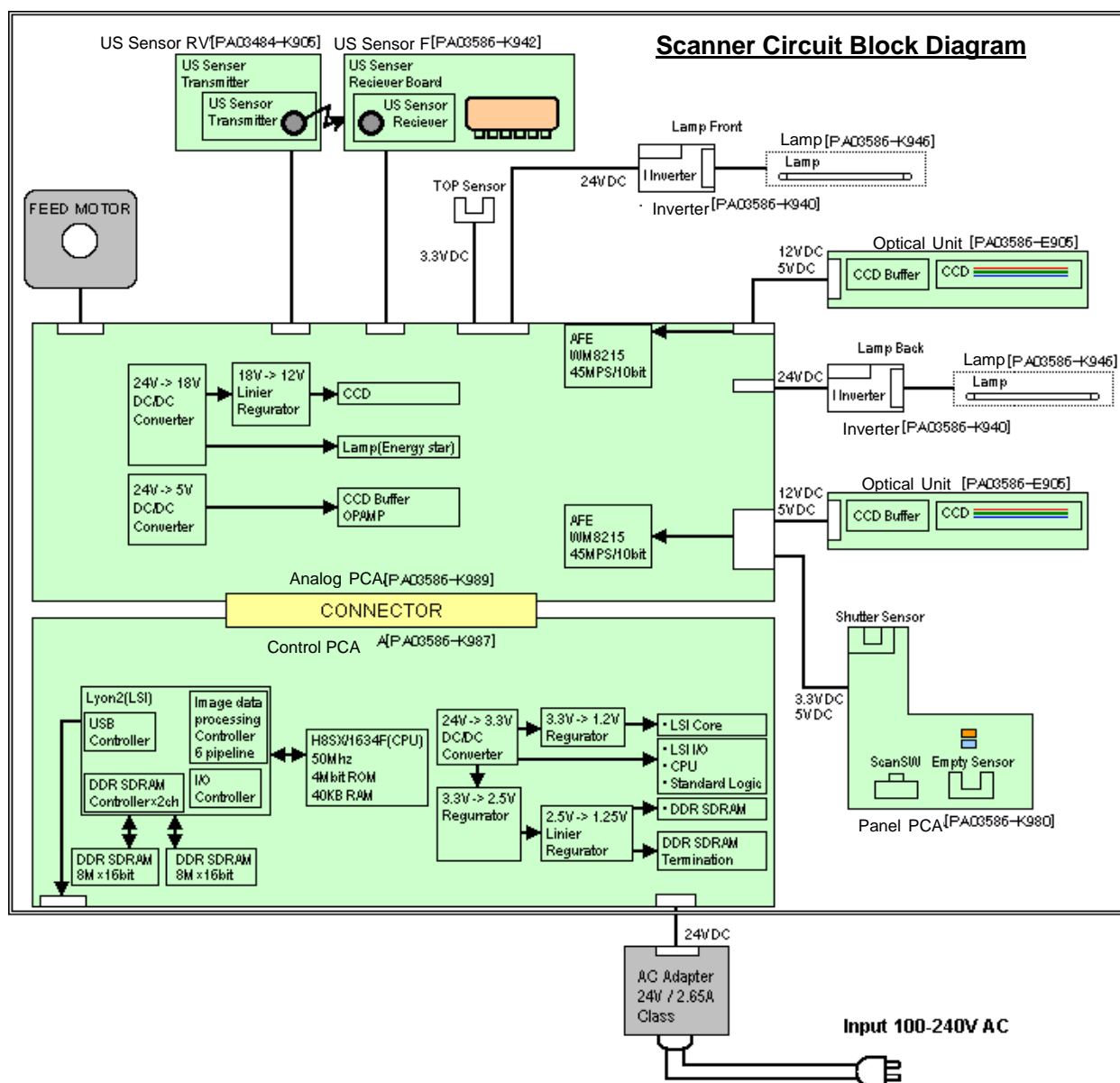

1.8 Consumables

The Pad ASSY and Pick Roller, the ScanSnap's consumables, can be replaced by users.

Consumable counters (Pad counter and Pick counter) are built in the ScanSnap in order to count the number of sheets each consumable feeds. Users can check the counter on ScanSnap Manager.

Service engineers can check / reset the counter with the Test Program. (Resetting the counter is required after the consumable replacement).

No.	Part name	Specifications	Standard replacement cycle *
1	Pick roller	PA03586-0001	100,000 sheets or one year
2	Pad ASSY	PA03586-0002	50,000 sheets or one year

See Section 7.3.2 for how to reset the counter and replace the consumables.

						TITLE	ScanSnap S1500/S1500-SR/S1500M MAINTENANCE MANUAL			
						DRAW. No.	P1PA03586-B00X/6		CUST.	
Rev	DATE	DESIG.	CHECK	APPR.	DESCRIPTION	PFU LIMITED			PAGE	18/140
02	Jan. 23, 2009	K.Okada	T.Anzai	IFujioka	Refer to Revision Record on page 2.					
DESIG	Jan. 9, 2009	K.Okada	CHECK	T.Anzai	APPR.	IFujioka				

Chapter 2 Installation

2.1 Unpacking the ScanSnap

Follow the procedure below to unpack the ScanSnap. Make sure that all the accessories are included in the package.

1. Open the package box.
2. Remove the AC adapter.
3. Remove the AC plate and cushions TL and TR.
4. Remove the ScanSnap from the package box and then from the polyethylene bag. Peel off the protective tapes.
5. Remove the accessory tray and the Carrier Sheet.

The following table is the packaging configuration.

No.	Items	Quantity
1	Package box	1
2	Carrier Sheet	1
3	Accessory Tray	1
4	ScanSnap	1
5	AC Adapter	
6	Cushion (BR)	1
7	Cushion (BL)	1
8	Cushion (TR)	1
9	Cushion (TL)	1
10	AC plate	1

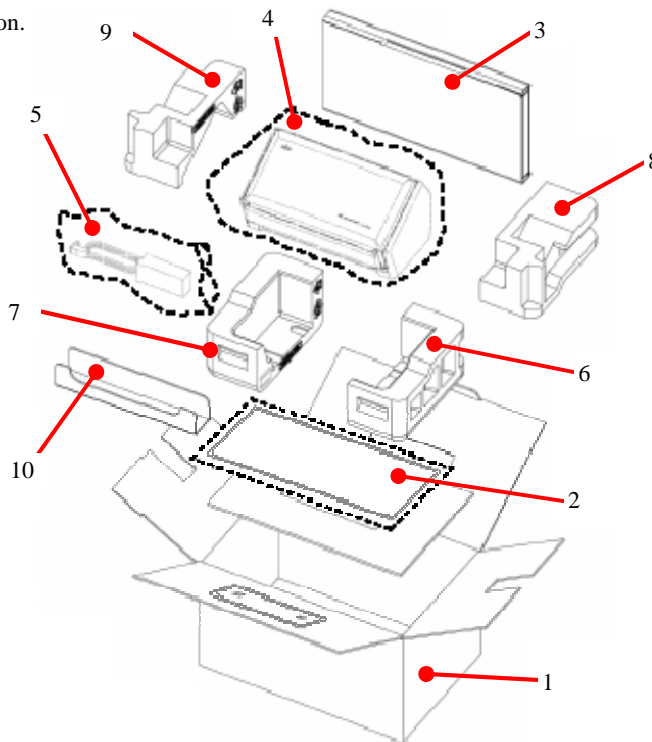

2.2 Installing the ScanSnap

2.2.1 For Safety Installation

Before installing the ScanSnap, read the following cautions carefully to avoid scanner trouble.

Refer to Section 1.1.4 “Environmental Specifications” for information of input power and scanner dimensions.

- Install the ScanSnap away from strong magnetic fields and other sources of noise.
- Do not install the ScanSnap near heating apparatus or in the direct sunlight.
- Install the ScanSnap in a location that is level and subject to minimal vibration.
- Do not install the ScanSnap in locations subject to humidity and dust.
- Do not block the ventilation ports.
- Protect the ScanSnap from static electricity.
- Use proper AC voltage.
- Make sure the rubber pads on the bottom of the ScanSnap are level on the table or desk.

						TITLE	ScanSnap S1500/S1500-SR/S1500M MAINTENANCE MANUAL				
						DRAW. No.	P1PA03586-B00X/6	CUST.			
02	Jan. 23, 2009	K.Okada	T.Anzai	IFujioka	Refer to Revision Record on page 2.						
Rev	DATE	DESIG.	CHECK	APPR.	DESCRIPTION				PFU LIMITED	PAGE	19/140
DESIG	Jan. 9, 2009	K.Okada	CHECK	T.Anzai		APPR.	IFujioka				

2.2.2 Installation

NOTICE

Install ScanSnap Manager before connecting the ScanSnap and the computer.

- (1) Install the necessary software. After rebooting the PC, connect the ScanSnap and PC in the following procedure.
- (2) Connect the AC cable to the AC adapter (collectively called the "Power cable").
- (3) Plug the power cable into the power connector at the back of the ScanSnap, and the other end to and AC outlet.

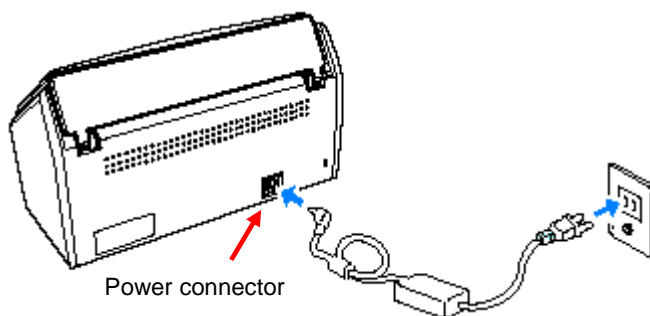
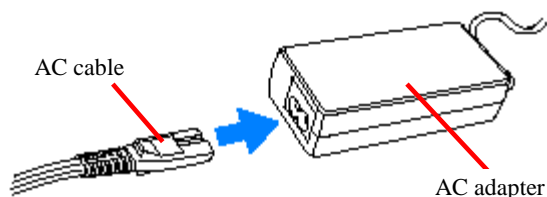

- (4) Remove the tape covering the USB connector of the ScanSnap, and connect the USB cable to the ScanSnap and the computer.

Notes on USB

- Be sure to use the supplied USB cable.
- When connecting to a USB hub, be sure to connect the ScanSnap to the hub nearest to your computer (first stage). If you connect it to a USB hub from the second stage onwards, the ScanSnap may not work properly.
- When connecting with a USB 2.0 cable, make sure that the USB port to connect to and hub must be USB 2.0-compliant. Note that if connected with a USB 1.1 cable, the scanning speed may become slow. When a USB 2.0-compliant port is available, it is recommended that the USB 2.0-compliant port be used.

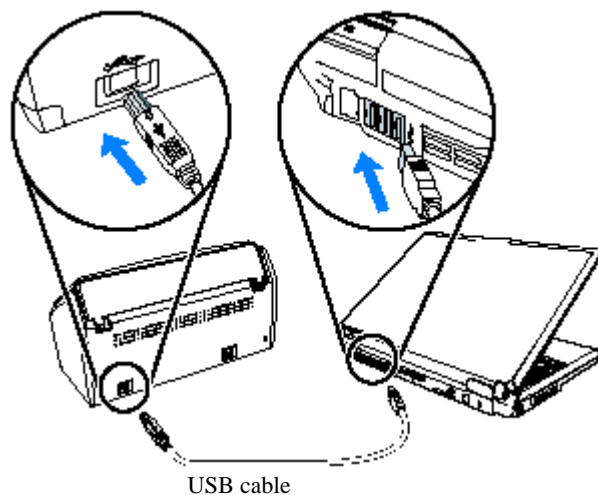

- (5) Opening the ADF Paper Chute of the ScanSnap turns the power on. The ScanSnap is automatically detected.

NOTICE

If the ScanSnap is not detected, check the procedures above again (installation and connection procedures).

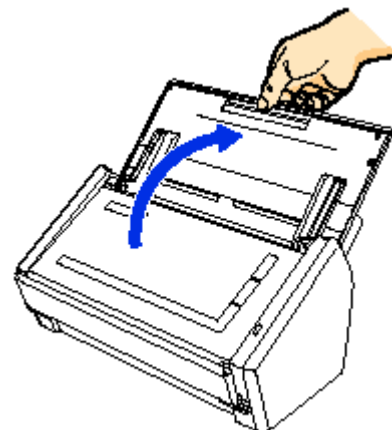

						TITLE	ScanSnap S1500/S1500-SR/S1500M MAINTENANCE MANUAL		
						DRAW. No.	P1PA03586-B00X/6	CUST.	
02	Jan. 23, 2009	K.Okada	T.Anzai	IFujioka	Refer to Revision Record on page 2.				
Rev	DATE	DESIG.	CHECK	APPR.	DESCRIPTION				
DESIG	Jan. 9, 2009	K.Okada	CHECK	T.Anzai		APPR.	IFujioka	PFU LIMITED	PAGE 20/140

Chapter 3 Maintenance Parts

3.1 Maintenance Parts List

POS	Description	Part number	Quantity				Appearance	Replacing Procedure
			S1500		S1500M			
1	REVOLVE UNIT	PA03586-D991	1				3.2.1	5.12
		PA03586-D995			1			
2	LAMP	PA03586-K946		1		1	3.2.2	5.10.4, 5.11.4
3	INVERTER	PA03586-K940		1		1	3.2.3	5.10.5, 5.11.5
4	OPTICAL UNIT	PA03586-E905		1		1	3.2.4	5.10.2, 5.11.3
5	PANEL PCA	PA03586-K980		1		1	3.2.5	5.11.2
6	US SENSOR RV	PA03484-K905		1		1	3.2.6	5.11.7
7	SENSOR ASSY B3	PA03586-F917		1		1	3.2.7	5.11.6
8	TOP COVER ASSY	PA03586-D981		1			3.2.8	5.11.1
		PA03586-D985				1		
9	FIXED UNIT	PA03586-D971	1			1	3.2.9	5.12
10	FIX SUB UNIT	PA03586-E901		1		1	3.2.10	5.10.9
11	MOTOR	PA03586-K981		1		1	3.2.11	5.10.3
12	PICK SHAFT ASSY	PA03586-K943		1		1	3.2.12	5.10.6
13	US SENSOR F	PA03586-K942		1		1	3.2.13	5.10.7
14	FEED ROLLER	PA03586-K984		1		1	3.2.14	5.10.8
15	EXIT ROLLER	PA03586-K983		1		1	3.2.15	5.10.1
16	CONTROL PCA	PA03586-K987	1			1	3.2.16	5.7
17	ANALOG PCA	PA03586-K989	1			1	3.2.17	5.7
18	GUIDE P ASSY	PA03586-E981	1				3.2.18	5.6.2
		PA03586-E985				1		
19	LIDCOV ASSY	PA03586-E971	1				3.2.19	5.6.1
		PA03586-E975				1		
20	Torque-Dumper	PA03586-K982	1			1	3.2.20	5.9
21	GUIDE A	PA03586-E961	1				3.2.21	5.8
		PA03586-E965				1		
22	CHUTE ASSY	PA03586-E951	1				3.2.22	5.6.4
		PA03586-E955				1		
23	STACKER ASSY	PA03586-E941	1				3.2.23	5.6.3
		PA03586-E945				1		
24	AC ADATER	PA03586-K931	1				3.2.24	-
		PA03586-K935				1		
25	AC CABLE E	PA63112-2001	1				3.2.25	-
		PA63117-2001				1		
	AC CABLE UK	PA63118-2001	1					
		PA63119-2001				1		
	AC CABLE U	PA63113-2001	1					
		PA63116-2001				1		
AC CABLE C	PA63115-1831	1						
	PA63143-1831				1			
26	USB CABLE	PA61001-0169	1				3.2.26	-
		PA61001-0170				1		
27	HK RING	PA03360-K941		1		1	3.2.31	5.10.1

						TITLE	ScanSnap S1500/S1500-SR/S1500M MAINTENANCE MANUAL			
						DRAW. No.	P1PA03586-B00X/6		CUST.	
02	Jan. 23, 2009	K.Okada	T.Anzai	IFujioka	Refer to Revision Record on page 2.					
Rev	DATE	DESIG.	CHECK	APPR.	DESCRIPTION				PAGE	21/140
DESIG	Jan. 9, 2009	K.Okada	CHECK	T.Anzai	APPR.	IFujioka			PFU LIMITED	

3.2 Maintenance Parts Specifications / Appearance

3.2.1 Revolve Unit

Description	Part number		Remarks
REVOLVE UNIT	PA03586-D991	For S1500	Includes: - Inverter - Lamp - Optical Unit - Panel PCA - Sensor ASSY B3 - US Sensor RV - Top Cover ASSY * *For S1500: Black Top Cover ASSY For S1500: White Top Cover ASSY
	PA03586-D995	For S1500M	

<For S1500>

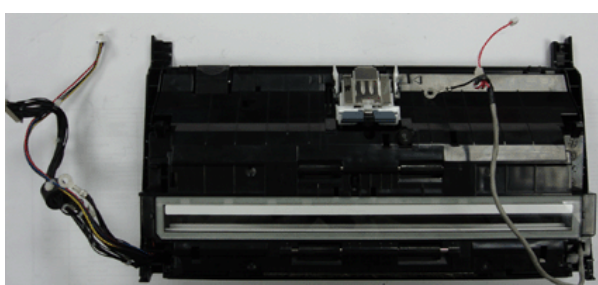

<For S1500M>

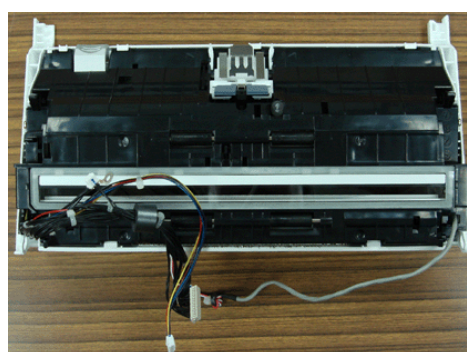

3.2.2 Lamp

Description	Part number	Remarks
LAMP	PA03586-K946	The Revolve Unit and the Fixed Unit include the Identical lamp.



						TITLE	ScanSnap S1500/S1500-SR/S1500M MAINTENANCE MANUAL		
						DRAW. No.	P1PA03586-B00X/6	CUST.	
02	Jan. 23, 2009	K.Okada	T.Anzai	IFujioka	Refer to Revision Record on page 2.		PFU LIMITED	PAGE	22/140
Rev	DATE	DESIG.	CHECK	APPR.	DESCRIPTION				
DESIG	Jan. 9, 2009	K.Okada	CHECK	T.Anzai		APPR.	IFujioka		

3.2.3 Inverter

Description	Part number	Remarks
INVERTER	PA03586-K940	The Revolve Unit and the Fixed Unit include the identical Inverter.

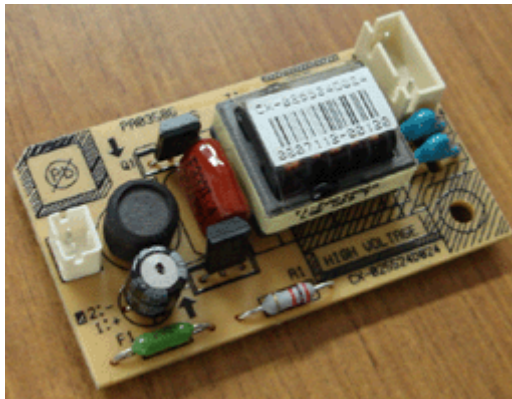

3.2.4 Optical Unit

Description	Part number	Remarks
OPTICAL UNIT	PA03586-E905	The Revolve Unit and the Fixed Unit include the identical Optical Unit.

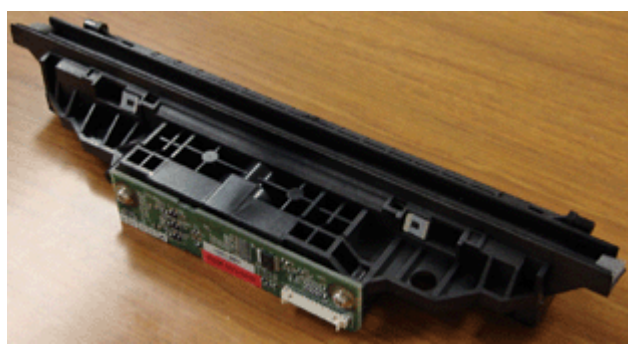

						TITLE	ScanSnap S1500/S1500-SR/S1500M MAINTENANCE MANUAL		
						DRAW. No.	P1PA03586-B00X/6	CUST.	
02	Jan. 23, 2009	K.Okada	T.Anzai	IFujioka	Refer to Revision Record on page 2.	PFU LIMITED		PAGE	23/140
Rev	DATE	DESIG.	CHECK	APPR.	DESCRIPTION				
DESIG	Jan. 9, 2009	K.Okada	CHECK	T.Anzai		APPR.	IFujioka		

3.2.5 Panel PCA

Description	Part number	Remarks
PANEL PCA	PA03586-K980	EEPROM data must be saved and restored before and after replaing the Panel PCA. Saving the data: Sectrion 6.3 Restoring the data: Section 6.4

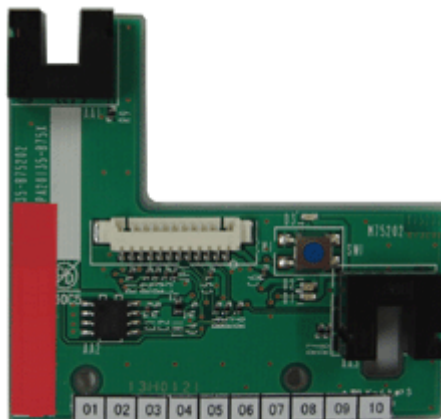

3.2.6 US Sensor RV

Description	Part number	Remarks
US SENSOR RV	PA03484-K905	

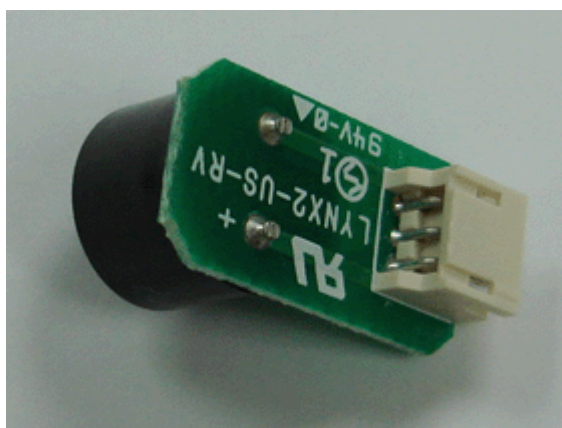

						TITLE	ScanSnap S1500/S1500-SR/S1500M MAINTENANCE MANUAL	
						DRAW. No.	P1PA03586-B00X/6	CUST.
02	Jan. 23, 2009	K.Okada	T.Anzai	IFujioka	Refer to Revision Record on page 2.		PFU LIMITED	PAGE 24/140
Rev	DATE	DESIG.	CHECK	APPR.	DESCRIPTION			
DESIG	Jan. 9, 2009	K.Okada	CHECK	T.Anzai	APPR.	IFujioka		

3.2.7 Sensor ASSY B3

Description	Part number	Remarks
SENSOR ASSY B3	PA03586-F917	

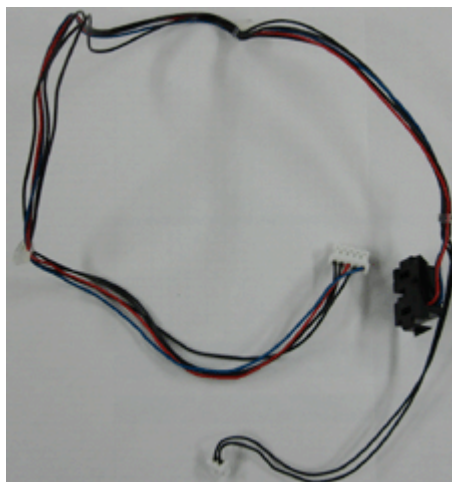

3.2.8 Top Cover ASSY

Description	Part number		Remarks
TOP COVER ASSY	PA03586-D981	For S1500	Black
	PA03586-D985	For S1500M	White

<For S1500>



<For S1500M>



						TITLE	ScanSnap S1500/S1500-SR/S1500M MAINTENANCE MANUAL			
						DRAW. No.	P1PA03586-B00X/6		CUST.	
02	Jan. 23, 2009	K.Okada	T.Anzai	IFujioka	Refer to Revision Record on page 2.					
Rev	DATE	DESIG.	CHECK	APPR.	DESCRIPTION			PFU LIMITED	PAGE	25/140
DESIG	Jan. 9, 2009	K.Okada	CHECK	T.Anzai		APPR.	IFujioka			

3.2.9 Fixed Unit

Description	Part number	Remarks
FIXED UNIT	PA03586-D971	Includes: - Inverter - Lamp - Optical Unit - Fix Sub Unit - Motor - Pick Shaft ASSY - Feed Roller - Exit Roller

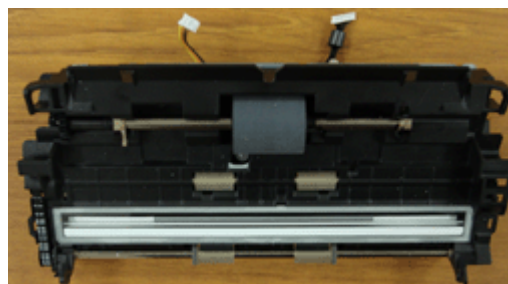

3.2.10 Fix Sub Unit

Description	Part number	Remarks
FIX SUB UNIT	PA03586-E901	Includes: - Motor - Feed Roller - Exit Roller.

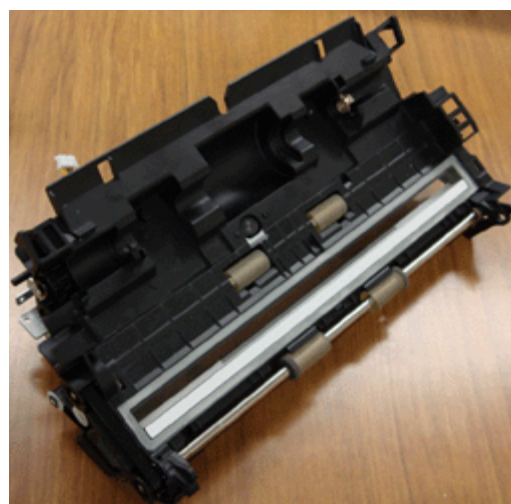

						TITLE	ScanSnap S1500/S1500-SR/S1500M MAINTENANCE MANUAL			
						DRAW. No.	P1PA03586-B00X/6		CUST.	
02	Jan. 23, 2009	K.Okada	T.Anzai	IFujioka	Refer to Revision Record on page 2.		PFU LIMITED		PAGE	26/140
Rev	DATE	DESIG.	CHECK	APPR.	DESCRIPTION		PFU LIMITED		PAGE	26/140
DESIG	Jan. 9, 2009	K.Okada	CHECK	T.Anzai		APPR.	IFujioka			

3.2.11 Motor

Description	Part number	Remarks
MOTOR	PA03586-K981	Adjust the belt tension after replacing the Motor. Refer to Section 5.13.



3.2.12 Pick Shaft ASSY

Description	Part number	Remarks
PICK SHAFT ASSY	PA03586-K943	The Pick Roller not included.

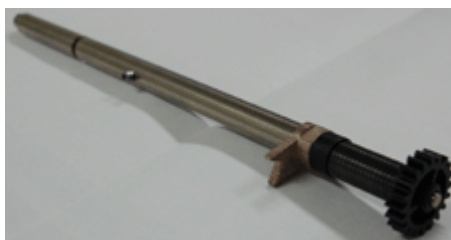

3.2.13 US Sensor F

Description	Part number	Remarks
US SENSOR F	PA03586-K942	

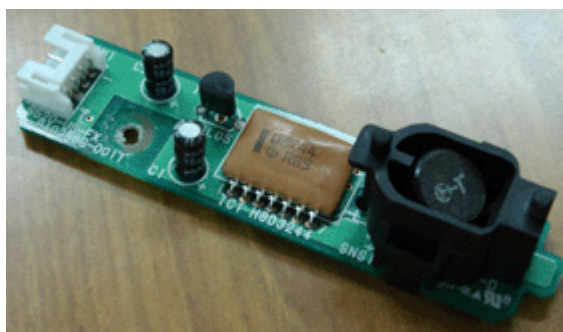

						TITLE	ScanSnap S1500/S1500-SR/S1500M MAINTENANCE MANUAL		
						DRAW. No.	P1PA03586-B00X/6	CUST.	
02	Jan. 23, 2009	K.Okada	T.Anzai	IFujioka	Refer to Revision Record on page 2.		PFU LIMITED	PAGE	27/140
Rev	DATE	DESIG.	CHECK	APPR.	DESCRIPTION				
DESIG	Jan. 9, 2009	K.Okada	CHECK	T.Anzai		APPR.	IFujioka		

3.2.14 Feed Roller

Description	Part number	Remarks
FEED ROLLER	PA03586-K984	Adjust the belt tension after replacing the Feed Roller. Refer to Section 5.13.



3.2.15 Exit Roller

Description	Part number	Remarks
EXIT ROLLER	PA03586-K983	Includes two HK Rings. Adjust the belt tension after replacing the Exit Roller. Refer to Section 5.13.

Exit Roller



HK Ring



						TITLE	ScanSnap S1500/S1500-SR/S1500M MAINTENANCE MANUAL		
						DRAW. No.	P1PA03586-B00X/6	CUST.	
02	Jan. 23, 2009	K.Okada	T.Anzai	IFujioka	Refer to Revision Record on page 2.		PFU LIMITED		PAGE 28/140
Rev	DATE	DESIG.	CHECK	APPR.	DESCRIPTION				
DESIG	Jan. 9, 2009	K.Okada	CHECK	T.Anzai		APPR.	IFujioka		

3.2.16 Control PCA

Description	Part number	Remarks
CONTROL PCA	PA03586-K987	



3.2.17 Analog PCA

Description	Part number	Remarks
ANALOG PCA	PA03586-K989	



3.2.18 Guide P ASSY

Description	Part number		Remarks
	GUIDE P ASSY	PA03586-E981	
PA03586-E985		For S1500M	White

<For S1500>

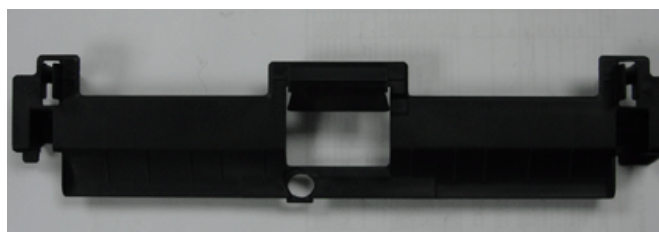

<For S1500M>

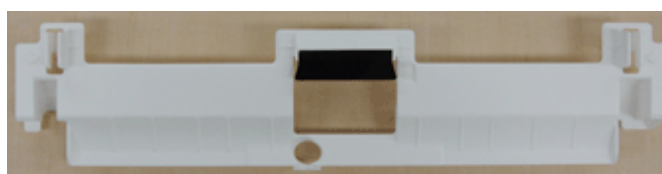

						TITLE	ScanSnap S1500/S1500-SR/S1500M MAINTENANCE MANUAL	
						DRAW. No.	P1PA03586-B00X/6	CUST.
02	Jan. 23, 2009	K.Okada	T.Anzai	IFujioka	Refer to Revision Record on page 2.			
Rev	DATE	DESIG.	CHECK	APPR.	DESCRIPTION		PFU LIMITED	PAGE
DESIG	Jan. 9, 2009	K.Okada	CHECK	T.Anzai		APPR.		IFujioka

3.2.19 LIDCOV ASSY

Description	Part number		Remarks
LIDCOV ASSY	PA03586-E971	For S1500	Front side: Silver Back side: Black
	PA03586-E975	For S1500M	Front side: Silver Back side: White



3.2.20 Torque-Dumper

Description	Part number	Remarks
Torque-Dumper	PA03586-K982	



						TITLE	ScanSnap S1500/S1500-SR/S1500M MAINTENANCE MANUAL	
						DRAW. No.	P1PA03586-B00X/6	CUST.
02	Jan. 23, 2009	K.Okada	T.Anzai	IFujioka	Refer to Revision Record on page 2.			
Rev	DATE	DESIG.	CHECK	APPR.	DESCRIPTION			
DESIG	Jan. 9, 2009	K.Okada	CHECK	T.Anzai		APPR.	IFujioka	
							PFU LIMITED	PAGE 30/140

3.2.21 Guide A

Description	Part number		Remarks
GUIDE A	PA03586-E961	For S1500	Black
	PA03586-E965	For S1500M	White

<For S1500>

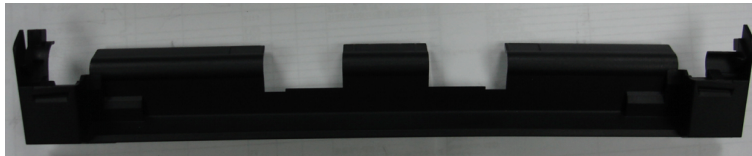

<For S1500M>



3.2.22 Chute ASSY

Description	Part number		Remarks
CHUTE ASSY	PA03586-E951	For S1500	Front side: Silver Back side: Black
	PA03586-E955	For S1500M	Front side: Silver Back side: White

<For S1500>



<For S1500M>

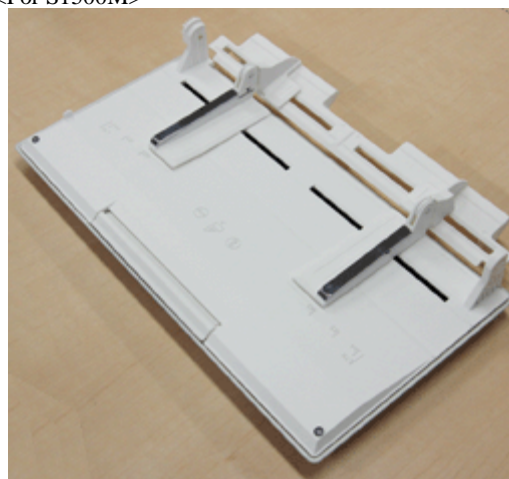

						TITLE	ScanSnap S1500/S1500-SR/S1500M MAINTENANCE MANUAL		
						DRAW. No.	P1PA03586-B00X/6	CUST.	
02	Jan. 23, 2009	K.Okada	T.Anzai	IFujioka	Refer to Revision Record on page 2.		PFU LIMITED	PAGE	31/140
Rev	DATE	DESIG.	CHECK	APPR.	DESCRIPTION				
DESIG	Jan. 9, 2009	K.Okada	CHECK	T.Anzai		APPR.	IFujioka		

3.2.23 Stacker ASSY

Description	Part number		Remarks
STACKER ASSY	PA03586-E941	For S1500	Black
	PA03586-E945	For S1500M	White

<For S1500>



<For S1500M>

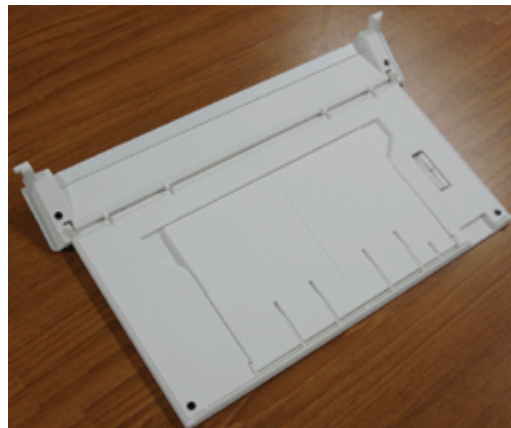

3.2.24 AC Adapter

Description	Part number		Remarks
AC ADAPTER	PA03586-K931	For S1500	Black
	PA03586-K935	For S1500M	White

<For S1500>



<For S1500M>



						TITLE	ScanSnap S1500/S1500-SR/S1500M MAINTENANCE MANUAL		
						DRAW. No.	P1PA03586-B00X/6		CUST.
02	Jan. 23, 2009	K.Okada	T.Anzai	IFujioka	Refer to Revision Record on page 2.		PFU LIMITED	PAGE	32/140
Rev	DATE	DESIG.	CHECK	APPR.	DESCRIPTION				
DESIG	Jan. 9, 2009	K.Okada	CHECK	T.Anzai		APPR.	IFujioka		

3.2.25 AC Cables

Description	Part number		Remarks	
AC CABLE E	PA63112-2001	For S1500	Black	For Europe
	PA63117-2001	For S5100M	White	
AC CABLE UK	PA63118-2001	For S1500	Black	For Europe (UK)
	PA63119-2001	For S5100M	White	
AC CABLE U	PA63113-2001	For S1500	Black	For North America
	PA63116-2001	For S5100M	White	
AC CABLE C	PA63115-1831	For S1500	Black	For China
	PA63143-1831	For S5100M	White	

<For S1500>

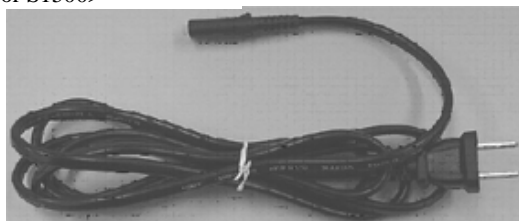

<For S1500M>

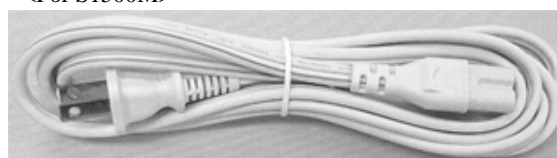

3.2.26 USB Cable

Description	Part number		Remarks
USB CABLE	PA61001-0169	For S1500	Black (Shared with S500/S510)
	PA61001-0170	For S5100M	White

<For S1500>



<For S1500M>



3.2.27 ~ 30 (Reserved)

3.2.31 HK Ring

Description	Part number	Remarks
HK Ring	PA03360-K941	Two pieces per set Shared with S500/S510



						TITLE	ScanSnap S1500/S1500-SR/S1500M MAINTENANCE MANUAL			
						DRAW. No.	P1PA03586-B00X/6	CUST.		
02	Jan. 23, 2009	K.Okada	T.Anzai	IFujioka	Refer to Revision Record on page 2.					
Rev	DATE	DESIG.	CHECK	APPR.	DESCRIPTION		PFU LIMITED		PAGE	33/140
DESIG	Jan. 9, 2009	K.Okada	CHECK	T.Anzai		APPR.	IFujioka			

Chapter 4 Troubleshooting

This section describes temporary errors and detection algorithm, and how to troubleshoot them.

4.1 Error Detection Algorithm

The ScanSnap has a function to indicate temporary errors and scanner alarms.

Temporary errors occur during scanning operation and can be remedied by the operator. They are displayed on the PC screen through the driver.

Scanner alarms may be displayed on a PC screen through the driver and/or on the Operator Panel (LED).

When an alarm occurs, the Operator Panel (LED) changes from blue to orange, and blinks several times according to the error type. The number of times the LED blinks is as shown in the table below.

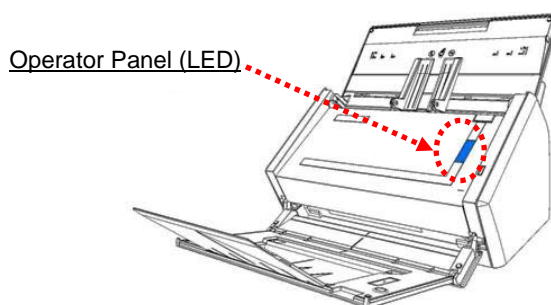

When an alarm occurs, the scanner displayed the following on the Operator Panel.

LED Display	Color	Description (supplement)
The number of times the LED blinks determines the Alarm	Orange	On → Off → On ... Off → Back to the beginning 0.5sec 0.5sec 0.5sec 2sec

When the **Scan** button is pressed while the LED is blinking, the scanner returns to the "Ready" status (Blue LED).

The following table is the Alarm display list.

Refer to the alarm detection algorithm (Section 4.3) for details.

Number of times LED blinks	Error Name	Description (supplement)
2	Optical alarm (ADF front)	Indicates when any scanning parts (Lamps, Inverters, Optical Units or cables) for the front or backside are defective.
3	Optical alarm (ADF back)	
4	Motor fuse blown	These are indicated three times during the initial processing immediately after power-on.
5	Operator Panel alarm	
6	EEPROM alarm	
7	Image memory alarm	
8	RAM alarm	
9	Control Chip for USB alarm	Loop down.
10	US Sensor alarm	These are indicated three times during the initial processing immediately after power-on.

						TITLE	ScanSnap S1500/S1500-SR/S1500M MAINTENANCE MANUAL		
						DRAW. No.	P1PA03586-B00X/6	CUST.	
02	Jan. 23, 2009	K.Okada	T.Anzai	I.Fujioka	Refer to Revision Record on page 2.		PFU LIMITED	PAGE	34/140
Rev	DATE	DESIG.	CHECK	APPR.	DESCRIPTION				
DESIG	Jan. 9, 2009	K.Okada	CHECK	T.Anzai		APPR.	I.Fujioka		

4.2 Temporary Error Detection Algorithm

No	Error Display		Detection algorithm and action to recover						
	Scanner Display	ScanSnap Manager Display							
1	None	“Paper jam occurred.”	<p>Name: Paper Jam</p> <p>Detection method: The error is detected when one of the followings occurs:</p> <ol style="list-style-type: none"> 1) A document does not reach the Top sensor while the ScanSnap has transported the document about 250 mm to pick. (The ScanSnap performs retry operation.) 2) The trailing edge of a document does not reach the Top sensor after the ScanSnap transports the document by the length (L) below. (The document may have slipped on the rollers.) <table border="1"> <tr> <td>Scan condition</td> <td>Transported length (L) after the leading edge</td> </tr> <tr> <td>Fixed size document scanning</td> <td>Approximately 450 mm</td> </tr> <tr> <td>Long page scanning</td> <td>1.2 times of the specified value</td> </tr> </table> <p>How to recover: Remove the jammed document and close the ADF. If the error persists, the Top Sensor (Replacing Sensor ASSY B3: Section 5.11.6) or Control PCA (Section 5.7) may be defect.</p>	Scan condition	Transported length (L) after the leading edge	Fixed size document scanning	Approximately 450 mm	Long page scanning	1.2 times of the specified value
Scan condition	Transported length (L) after the leading edge								
Fixed size document scanning	Approximately 450 mm								
Long page scanning	1.2 times of the specified value								
2	None	“There is not paper in the scanner.”	<p>Name: No paper on the Paper Chute</p> <p>Detection method: This error occurs when the Hopper empty sensor detects no paper loaded on the ADF Paper Chute at the receipt of Feed command.</p> <p>How to recover: Load documents on the ADF Paper Chute. If the error persists, the Empty Sensor may be defect. (Replacing Revolve Unit: Section 5.12)</p>						
3	None	“ADF Cover is open.”	<p>Name: ADF Cover Open</p> <p>Detection method: This error occurs when the Cover Open sensor detects that the ADF is not closed at the receipt of Feed command.</p> <p>How to recover: Close the ADF Top Section. If the error persists, the ADF Cover Open Sensor may be defect. (Replacing Fixed unit: Section 5.12)</p>						

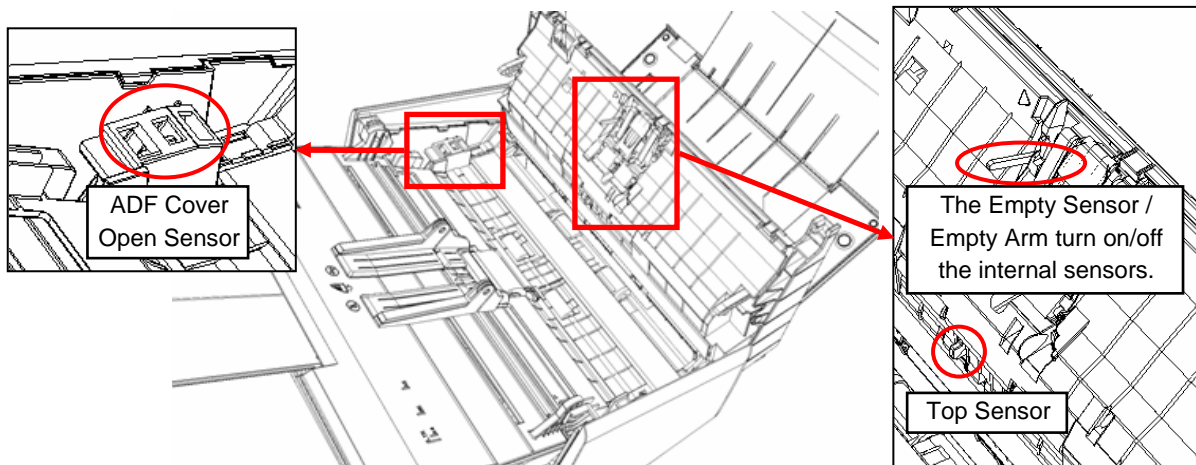

						TITLE	ScanSnap S1500/S1500-SR/S1500M MAINTENANCE MANUAL			
						DRAW. No.	P1PA03586-B00X/6	CUST.		
02	Jan. 23, 2009	K.Okada	T.Anzai	IFujioka	Refer to Revision Record on page 2.					
Rev	DATE	DESIG.	CHECK	APPR.	DESCRIPTION		PFU LIMITED		PAGE	35/140
DESIG	Jan. 9, 2009	K.Okada	CHECK	T.Anzai	APPR.	IFujioka				

4.3 Alarm Detection Algorithm

The alarm requires maintenance by an authorized service person. The following table shows the display and detection algorithm for the scanner errors. The errors are displayed on a PC screen and/or on the Operator panel (LED).

Scanner errors and their detection algorithms

No	Error Display		Detection algorithm and action to recover	Related Section
	Scanner Display	ScanSnap Manager Display		
1	LED blinks twice in Orange	“Error in optical system” “Error in optical system.”	<p>Name: Optical Alarm (ADF front) Detection method: This error occurs when READ command for the first document is received or white reference level is checked (Background scanning) during scanning. (Refer to (3) in Section 1.4 for details.)</p> <p>Probable causes:</p> <ul style="list-style-type: none"> - White reference is dirty (White area of the Background at the Revolve Unit side) - Lamp, Optical Unit, or inside of the Optical systems is dirty. (Fixed Unit side) - Optical Unit, Lamp or Inverter at Fixed Unit is defect - Connector disconnected 	4.4.11
2	LED blinks three times in Orange		<p>Name: Optical Alarm (ADF back) Detection method: Same as above</p> <p>Probable causes:</p> <ul style="list-style-type: none"> - White reference is dirty (White area of the Background at the Fixed Unit side) - Lamp, Optical Unit, or inside of the Optical systems is dirty. (Revolve Unit side) - Optical Unit, Lamp or Inverter at Revolve Unit side is defect. - Connector disconnected 	
3	LED blinks four times in Orange	None	<p>Name: Motor Fuse blown Detection method: This error occurs immediately after the monitor fuse is blown. For maintenance, Analog PCA needs replacing because the fuse is soldered to the Analog PCA.</p> <p>Probable causes:</p> <ul style="list-style-type: none"> - Bits of metal dropped on the Analog PCA - Insulating material of motor cable damaged - Insulation corrupted inside the motor - Defective Control PCA 	4.4.12
4	LED blinks five times in Orange	None	<p>Name: Operator Panel Alarm Detection method: Before the Panel PCA is replaced, EEPROM data in Panel PCA must be temporarily saved onto the Control PCA, and the information that this Panel PCA no longer has the EEPROM data is written. Operator panel alarm occurs if no EEPROM data existence on the Panel PCA is detected during the initial processing immediately after power-on.</p> <p>Probable causes:</p> <ul style="list-style-type: none"> - Old Panel PCA that has EEPROM data stored was mounted when replaced. - Defective Panel PCA 	4.4.13

						TITLE	ScanSnap S1500/S1500-SR/S1500M MAINTENANCE MANUAL		
						DRAW. No.	P1PA03586-B00X/6	CUST.	
02	Jan. 23, 2009	K.Okada	T.Anzai	IFujioka	Refer to Revision Record on page 2.				
Rev	DATE	DESIG.	CHECK	APPR.	DESCRIPTION	PFU LIMITED		PAGE	36/140
DESIG	Jan. 9, 2009	K.Okada	CHECK	T.Anzai		APPR.	IFujioka		

No	Error Display		Detection algorithm and action to recover	Related Section
	Scanner Display	ScanSnap Manager Display		
5	LED blinks six time in Orange Note 1	None	Name: EEPROM alarm Detection method: This error is detected by comparing data in EEPROM during the initial processing immediately after power-on. Probable cause: - Damaged EEPROM in Panel PCA - Defective Panel PCA	4.4.14
6	LED blinks seven time in Orange Note 1	None	Name: Image Memory Alarm Detection method: This error is detected by read/write diagnostics and bus diagnostics during initial processing immediately after power-on. Probable cause: Defective Control PCA (defective memory)	4.4.15
7	LED blinks eight time in Orange Note 1	None	Name: RAM Alarm Detection Method Detection method: This error is detected by read/write diagnostics and bus diagnostics. Probable cause: Defective Control PCA	4.4.15
8	LED blinks nine time in Orange Note 1	None	Name: USB Control Chip Alarm Detection method: This error is detected by read/write diagnostics and bus diagnostics. Probable cause: Defective Control PCA	4.4.15
9	None	"Data transfer error occurred."	Name: Data Transfer Alarm Detection method: This error is detected during image transfer when the LSI could not generate the image. Probable cause: Defective Control PCA	4.4.16
10	LED blinks ten times in Orange	None	Name: US Sensor Alarm Detection method: This error is detected when the US Sensor signal could not be received. Probable causes: - Defective US Sensor - Defective Analog PCA	4.4.17

Note 1: The errors No.4 to 6 and 10 are displayed 3 times during the initial processing immediately power-on. When more than one of these errors occurs simultaneously, they are displayed in the order of the priority described below:

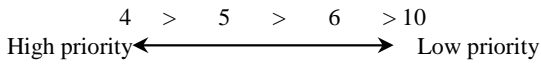

The ScanSnap can perform a scan operation even if these errors occur, but the operation might not be proper.

- For instance, when EEPROM is damaged, the document is scanned by default settings, which means the magnification, offset and white level settings may not be at the optimum value for the document to be scanned.
- When the image memory is damaged, irregular image may appear which can be easily detected by a visual check.

						TITLE	ScanSnap S1500/S1500-SR/S1500M MAINTENANCE MANUAL			
						DRAW. No.	P1PA03586-B00X/6	CUST.		
02	Jan. 23, 2009	K.Okada	T.Anzai	IFujioka	Refer to Revision Record on page 2.					
Rev	DATE	DESIG.	CHECK	APPR.	DESCRIPTION		PFU LIMITED		PAGE	37/140
DESIG	Jan. 9, 2009	K.Okada	CHECK	T.Anzai		APPR.	IFujioka			

4.4 Troubleshooting

When a Temporary error or an Alarm occurs, find the troubleshooting procedure from the list in this section for maintenance. Before starting the troubleshooting, get the following information from your customer to understand whether the error is scanner-related or system-related.

- Is the ScanSnap operated correctly?
- Are the fault symptoms reproducible or persistent?
(Check if the target ScanSnap causes the same error connected to the other computer systems.)

NOTICE How to troubleshoot

The troubleshooting should be conducted from item number 1 to the last item number in each table. Continue the troubleshooting until the error is corrected.

The following table lists the errors to troubleshoot and their related sections.

Error category	Error description	Related section	Remarks
Device	Scanner does not turn ON. (LED does not light on the operator panel)	4.4.1	
	Scanning does not start.	4.4.2	
Image	Scanned image is distorted.	4.4.3	
	Too much jitter on scanned image.	4.4.4	
	Offset or image size is incorrect.	4.4.5	
	Vertical streaks appear in scanned image	4.4.6	
Temporary error	Frequent paper jam	4.4.7	
	No paper on the ADF Paper Chute	4.4.8	
	ADF cover open	4.4.9	
	Multi feed	4.4.10	
Alarm	Optical alarm (ADF front side or ADF backside)	4.4.11	
	Motor fuse blown	4.4.12	
	Operator panel alarm	4.4.13	
	EEPROM alarm	4.4.14	
	Image memory alarm	4.4.15	
	RAM alarm	4.4.15	
	USB Control chip alarm	4.4.15	
	Data transfer error	4.4.16	
	US Sensor alarm	4.4.17	

Rev	DATE	DESIG.	CHECK	APPR.	DESCRIPTION	TITLE	DRAW. No.		CUST.
02	Jan. 23, 2009	K.Okada	T.Anzai	IFujioka	Refer to Revision Record on page 2.	ScanSnap S1500/S1500-SR/S1500M MAINTENANCE MANUAL	P1PA03586-B00X/6		
							PFU LIMITED	PAGE	38/140
DESIG	Jan. 9, 2009	K.Okada	CHECK	T.Anzai			APPR.	IFujioka	

4.4.1 Scanner does not Turn ON (No LED blinking on the operator Panel)

Item No.	Check items	Answer	How/where to check
1	Check to see if the AC cable and the AC adapter are connected properly. (Measure the output voltage with a tester.) 	Yes	Proceed to No.2. Confirm the following: Rated voltage: 24V Output voltage: 22.8 ~ 26.6V
		No	Replace the AC Cable or AC Adapter.
2	Turn off the PC power then turn it on again. Is the power on?	Yes	End.
		No	Proceed to No.3.
3	Close the ADF Paper Chute to turn off the power. After two seconds or more, open the ADF Paper Chute to turn on the power. Is the power on?	Yes	The Panel PCA seems operating properly, but the power is not turned on. Confirm if the error recurs after replacing the Control PCA and the Analog PCA (See Section 5.7).
		No	The Panel PCA, Control PCA, or Analog PCA might be defective. Replace them in the order above and see if the problem is resolved. Panel PCA: Section 5.11.2 Control PCA, Analog PCA: Section 5.7

						TITLE	ScanSnap S1500/S1500-SR/S1500M MAINTENANCE MANUAL		
						DRAW. No.	P1PA03586-B00X/6	CUST.	
02	Jan. 23, 2009	K.Okada	T.Anzai	IFujioka	Refer to Revision Record on page 2.		PFU LIMITED	PAGE	39/140
Rev	DATE	DESIG.	CHECK	APPR.	DESCRIPTION				
DESIG	Jan. 9, 2009	K.Okada	CHECK	T.Anzai		APPR.		IFujioka	

4.4.2 Scanning Does not Start

Item No.	Check items	Answer	How/where to check
1	Does the LED on the Control panel light?	Yes	If a Temporary error or an Alarm is displayed on the Control panel, follow the corresponding troubleshooting. If there is no error or alarm, proceed to No.2.
		No	Check the ScanSnap referring to Section 4.3.1.
2	Does ScanSnap Manager operate properly? (If the icon changes to  , ScanSnap Manager is not operating properly.)	Yes	Proceed to No.6.
		No	Proceed to No.3.
3	Close the ADF Paper Chute to turn off the power. After two seconds or more, open the ADF Paper Chute to turn on the power. Is the problem solved?	Yes	End.
		No	Proceed to No.4.
4	Check if the USB cable is connected properly. If you use a USB hub, connect the ScanSnap directly to the PC. Is the problem solved?	Yes	End.
		No	Proceed to No.5.
5	Restart the computer. Is the problem solved?	Yes	End.
		No	Re-install ScanSnap Manager.
6	If the "Scan and Save Setting" window is still displayed, close the window and restart to scan the document. Is the problem solved?	Yes	End.
		No	Replace the Control PCA and the Analog PCA (Refer to Section 5.7).

						TITLE	ScanSnap S1500/S1500-SR/S1500M MAINTENANCE MANUAL			
						DRAW. No.	P1PA03586-B00X/6		CUST.	
02	Jan. 23, 2009	K.Okada	T.Anzai	IFujioka	Refer to Revision Record on page 2.					
Rev	DATE	DESIG.	CHECK	APPR.	DESCRIPTION			PFU LIMITED	PAGE	40/140
DESIG	Jan. 9, 2009	K.Okada	CHECK	T.Anzai		APPR.	IFujioka			

4.4.3 Scanned Image is Distorted

Due to loose connectors, damaged wires in cable harnesses, or defective parts, scanned images may have regular or random patterns of distortion on them. This kind of distorted image can be trouble-shot with the following procedure.

Item No.	Check items	Answer	How/where to check
1	Is the USB cable connected properly?	Yes	Proceed to No.2.
		No	Connect the USB cable properly.
2	Is a Temporary error or an Alarm displayed on the LED?	Yes	Follow the corresponding troubleshooting.
		No	Proceed to No.3.
3	Which side of the image is distorted, front side or backside?	Front side	Proceed to No.4.
		Backside	Proceed to No.6.
4	Check to see if the cable between the Control PCA and Optical Unit (for front side scanning) is not damaged and the connector is properly connected. (Refer to Section 5.10.2.)	Yes	Proceed to No.5.
		No	Connect it without fail.
5	Replace the Optical Unit (for front side scanning). (Refer to Section 5.10.1) Is the problem solved?	Yes	End.
		No	Replace the Control PCA and Analog PCA. (Refer to Section 5.7)
6	Check to see if the cable between the Control PCA and Optical Unit (for backside scanning) is not damaged and the connector is properly connected. (Refer to Section 5.11.3.)	Yes	Proceed to No.7.
		No	Connect it without fail.
7	Replace the Optical unit (for backside scanning). (Refer to Section 5.11.3). Is the problem solved?	Yes	End.
		No	Replace the Control PCA and Analog PCA. (Refer to Section 5.7)

						TITLE	ScanSnap S1500/S1500-SR/S1500M MAINTENANCE MANUAL			
						DRAW. No.	P1PA03586-B00X/6		CUST.	
02	Jan. 23, 2009	K.Okada	T.Anzai	IFujioka	Refer to Revision Record on page 2.					
Rev	DATE	DESIG.	CHECK	APPR.	DESCRIPTION		PFU LIMITED		PAGE	41/140
DESIG	Jan. 9, 2009	K.Okada	CHECK	T.Anzai		APPR.	IFujioka			

4.4.4 Too Much Jitter on Scanned Image when Scanning from the ADF

The following picture shows a sample of a scanned image where “Jitter” error occurred. This error occurs when the ADF feed rollers do not transport the document smoothly.

Scanned image with jitter

A B C D E F G

Normal scanned image

A B C D E F G

Item No.	Check items	Answer	How/where to check
1	Does the document being scanned meet the paper specification? (Refer to Section 1.2).	Yes	Proceed to No.2.
		No	Remove the unspecified paper if any.
2	Clean the Feed rollers, Plastic rollers and Exit rollers. (Refer to Section 7.2.3) Is the problem solved?	Yes	End.
		No	Proceed to No.3.
3	Replace the Pick roller and Pad ASSY. (Refer to Section 7.3.4 or 7.3.5.) Is the problem solved?	Yes	End.
		No	Proceed to No.4.
4	Is the belt tension adjusted properly? Is the Motor installed properly? (Refer to Section 5.10.3.)	Yes	End.
		No	Proceed to No.5.
5	Check to see if the cable between the Analog PCA and the Motor is properly connected. (Refer to Section 5.7.5)	Yes	Proceed to No.6.
		No	Connect it without fail.
6	Replace the Motor. (Refer to Section 5.10.3.) Is the problem solved?	Yes	End.
		No	Proceed to No.7.
7	Replace the Fixed Unit. (Refer to Section 5.12.) Is the problem solved?	Yes	End.
		No	Replace the Control PCA and the Analog PCA. (Refer to Section 5.7.)

						TITLE	ScanSnap S1500/S1500-SR/S1500M MAINTENANCE MANUAL		
						DRAW. No.	P1PA03586-B00X/6	CUST.	
02	Jan. 23, 2009	K.Okada	T.Anzai	IFujioka	Refer to Revision Record on page 2.	PFU LIMITED		PAGE	42/140
Rev	DATE	DESIG.	CHECK	APPR.	DESCRIPTION				
DESIG	Jan. 9, 2009	K.Okada	CHECK	T.Anzai		APPR.	IFujioka		

4.4.5 Offset or Image Size is incorrect

Offset: Indicates the distance from the top or left edge of the image data to the document image.

Image size: Indicates the document image size corresponding to the actual document dimensions (length and width)

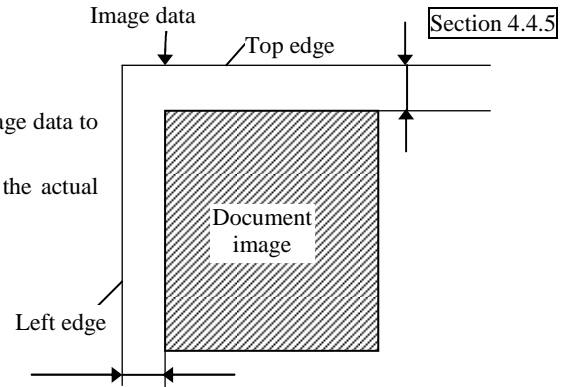

Item No.	Check items	Answer	How/where to check
1	Does the document being scanned meet the paper specification? (Refer to Section 1.2.)	Yes	Proceed to No.2.
		No	Use a specified paper.
2	Clean the Feed rollers, Plastic rollers and Exit rollers. (Refer to Section 7.2.3.) Is the problem solved?	Yes	End.
		No	Proceed to No.3.
3	Replace the Pick roller and Pad ASSY. (Refer to Section 7.3.4 or 7.3.5.) Is the problem solved?	Yes	End.
		No	Proceed to No.4.
4	Adjust the images using Test program. (Refer to Section 6.6.) Is the problem solved?	Yes	The ScanSnap satisfies the specification. Check Item No.1 ~ No.3 again.
		No	Proceed to No.5.
5	Is the Sensor ASSY B3 installed properly and working properly? (Refer to Section 5.11.6)	Yes	Proceed to No.6.
		No	Install the Sensor ASSY B3 properly or replace it.
6	Is the belt tension adjusted properly? Is the Motor installed properly? (Refer to Section 5.10.3.) Is the problem solved?	Yes	End.
		No	Proceed to No.7.
7	Check to see if the cable between the Control PCA and Motor is not damaged and the connector is properly connected. (Refer to Section 5.10.3.)	Yes	Proceed to No.8.
		No	Connect it without fail.
8	Replace the Motor. (Refer to Section 5.10.3.) Is the problem solved?	Yes	End.
		No	Proceed to No.9.
9	Check to see if the Optical Unit which scanned the image incorrectly is installed properly. Front side image: Refer to Section 5.10.2. Backside image: Refer to Section 5.11.3.	Yes	Proceed to No.10.
		No	Reinstall the Optical Unit.
10	Replace the Revolve unit. (Refer to Section 5.12.) Is the problem solved?	Yes	End.
		No	Proceed to No.11.
11	Replace the Fixed unit. (Refer to Section 5.12.) Is the problem solved?	Yes	End.
		No	Replace the Control PCA and Analog PCA. (Refer to Section 5.7.)

						TITLE	ScanSnap S1500/S1500-SR/S1500M MAINTENANCE MANUAL		
						DRAW. No.	P1PA03586-B00X/6	CUST.	
02	Jan. 23, 2009	K.Okada	T.Anzai	IFujioka	Refer to Revision Record on page 2.				
Rev	DATE	DESIG.	CHECK	APPR.	DESCRIPTION	PFU LIMITED		PAGE	43/140
DESIG	Jan. 9, 2009	K.Okada	CHECK	T.Anzai	APPR.	IFujioka			

4.4.6 Vertical Streaks Appear in Scanned Image

Item No.	Check items	Answer	How/where to check
1	Clean the glass, Pick roller, Pad ASSY and Feed rollers. (Refer to Section 7.2.3) Is the problem solved?	Yes	End.
		No	Proceed to No.2.
2	Adjust the image by Test program with a clean test sheet (Refer to Section 6.6). Is the problem solved?	Yes	End.
		No	Proceed to No.3.
3	Clean the Optical Unit on the side where vertical streaks appear. (Refer to Section 5.3.1.) Is the problem solved?	Yes	End
		No	Proceed to No.4.
4	Check to see if the cable between the Control PCA and the Optical Unit on the side where vertical streaks appear is not damaged and the connector of above cable is connected. Front side image: Section 5.10.2 Backside image: Section 5.11.3	Yes	Proceed to No.5.
		No	Connect it without fail.
5	Replace the Optical Unit on the side where vertical streaks appear. Front side image: Section 5.10.2. Backside image: Section 5.11.3. Is the problem solved?	Yes	End.
		No	Replace the Control PCA and the Analog PCA. (Refer to Section 5.7.)

4.4.7 Frequent Document Jam Error

Item No.	Check items	Answer	How/where to check
1	Does the document being scanned meet the paper specification? (Refer to Section 1.2.)	Yes	Proceed to No.2.
		No	Use a specified paper.
2	Are the edges of the document aligned? • Align the edge of documents for stable paper feeding. • Remove documents with creases or dog-ear corners. • Scanning different widths of documents may cause skew and result in paper jam.	Yes	Proceed to No.3.
		No	Align the document edges.
3	Clean the Feed Rollers, Exit rollers and Plastic Rollers. (Refer to Section 7.2.3.) Is the problem solved?	Yes	End.
		No	Proceed to No.4.
4	Check the consumable counter from the ScanSnap Manager or Test program (Section 6.5). When the counter exceeds the values shown in Section 7.3.1, replace the Pick roller or Pad ASSY. (Refer to Section 7.3.4 or 7.3.5.) Is the problem solved?	Yes	End.
		No	Proceed to No.5.
5	Replace the Pick Shaft ASSY (pick roller shaft). (Refer to Section 5.10.6.) Is the problem solved?	Yes	End.
		No	Proceed to No.6.
6	Replace the Sensor ASSY B3. (Refer to Section 5.11.6.) Is the problem solved?	Yes	End.
		No	Proceed to No.7.
7	Replace the Revolve Unit. (Refer to Section 5.12.) Is the problem solved?	Yes	End.
		No	Proceed to No.8.
8	Replace the Fixed Unit. (Refer to Section 5.12.) Is the problem solved?	Yes	End.
		No	Replace the Control PCA and the Analog PCA. (Refer to Section 5.7.)

						TITLE	ScanSnap S1500/S1500-SR/S1500M MAINTENANCE MANUAL			
						DRAW. No.	P1PA03586-B00X/6	CUST.		
02	Jan. 23, 2009	K.Okada	T.Anzai	IFujioka	Refer to Revision Record on page 2.					
Rev	DATE	DESIG.	CHECK	APPR.	DESCRIPTION			PFU LIMITED	PAGE	44/140
DESIG	Jan. 9, 2009	K.Okada	CHECK	T.Anzai		APPR.	IFujioka			

4.4.8 No Paper on the ADF Paper Chute

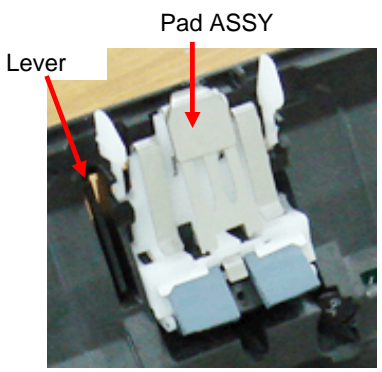
Item No.	Check items	Answer	How/where to check
1	Does the document being scanned meet the paper specification? (Refer to Section 1.2.)	Yes	Proceed to No.2.
		No	Use a specified paper.
2	Do any paper strips remain around the Empty sensor lever? Is the problem solved? <div style="text-align: center;">  </div>	Yes	End.
		No	Proceed to No.3.
3	Replace the Panel PCA. (Refer to Section 5.11.2.) Is the problem solved?	Yes	End.
		No	Replace the Control PCA and the Analog PCA. (Refer to Section 5.7.)

4.4.9 ADF Cover Open

Item No.	Check items	Answer	How/where to check
1	Close the ADF Paper Chute to turn the scanner OFF. After two seconds or more, open the ADF Paper Chute to turn the scanner ON. Is the problem solved?	Yes	End.
		No	Proceed to No.2.
2	Are any paper strips remaining around the Cover open sensor (See photo below)? Is the problem solved? <div style="text-align: center;">  </div>	Yes	Proceed to No.3.
		No	Remove paper strips.
3	Replace the Revolve unit. (Refer to Section 5.12.) Is the problem solved?	Yes	End.
		No	Replace the Control PCA and the Analog PCA. (Refer to Section 5.7.)

						TITLE	ScanSnap S1500/S1500-SR/S1500M MAINTENANCE MANUAL			
						DRAW. No.	P1PA03586-B00X/6	CUST.		
02	Jan. 23, 2009	K.Okada	T.Anzai	IFujioka	Refer to Revision Record on page 2.					
Rev	DATE	DESIG.	CHECK	APPR.	DESCRIPTION			PFU LIMITED	PAGE	45/140
DESIG	Jan. 9, 2009	K.Okada	CHECK	T.Anzai	APPR.	IFujioka				

4.4.10 Multi Feed

Item No.	Check items	Answer	How/where to check
1	Are the edges of the document aligned? <ul style="list-style-type: none"> • Align the edge of documents for stable paper feeding. • Remove documents with crease or dog-ear. • Scanning different widths of documents may cause skew and result in multi feed. 	Yes	Proceed to No.2.
		No	Align the document edges.
2	Clean the rollers at the ADF section. (Refer to Section 7.2.3.) Is the problem solved?	Yes	End.
		No	Proceed to No.3.
3	Check the consumable counter from ScanSnap Manager or Test program. (Refer to Section 6.5.) When the counter exceeds the values shown in Section 7.3.1, replace the Pick roller or Pad ASSY. (Refer to Sections 7.3.4, 7.3.5.) Is the problem solved?	Yes	End.
		No	Proceed to No.4.
4	Replace the Revolve unit. (Refer to Section 5.12.) Is the problem solved?	Yes	End.
		No	Proceed to No.5.
5	Replace the Fixed unit. (Refer to Section 5.12.) Is the problem solved?	Yes	End.
		No	Replace the Control PCA and the Panel PCA. (Refer to Section 5.7.)

4.4.11 Optical Alarm (ADF Front Side or ADF Back Side)

Item No.	Check items	Answer	How/where to check
1	Close the ADF Paper Chute to turn the scanner OFF. After two seconds or more, open the ADF Paper Chute to turn the scanner ON. Is the problem solved?	Yes	End.
		No	Proceed to No.2.
2	Clean the glass surface of the white background (white reference sheet) in the scanning area. (Refer to Section 7.2.3.) Is the problem solved?	Yes	End.
		No	Proceed to No.3.
3	Check to see if the LED at the side where the alarm occurs is on. Open the ADF and press the Cover open sensor to see if the LED lights up. If the lamp does not light up, the error may be caused by the defective LED. Is the LED ON?	Yes	Proceed to No.4.
		No	Replace the defective Lamp that does not light. <ul style="list-style-type: none"> • Front side optical alarm: Section 5.10.4 • Backside optical alarm: Section 5.11.4
4	Clean the Optical Unit at the side where the alarm occurs. (Refer to Section 5.3.1.)	Yes	End.
		No	Proceed to No.5.
5	Check to see if the cable between the Optical Unit and the Analog PCA is not damaged and the connector is connected.	Yes	Replace the defective Optical Unit. <ul style="list-style-type: none"> • Front side optical alarm: Section 5.10.2 • Backside optical alarm: Section 5.11.3
		No	Connect it without fail.

						TITLE	ScanSnap S1500/S1500-SR/S1500M MAINTENANCE MANUAL			
						DRAW. No.	P1PA03586-B00X/6	CUST.		
02	Jan. 23, 2009	K.Okada	T.Anzai	IFujioka	Refer to Revision Record on page 2.					
Rev	DATE	DESIG.	CHECK	APPR.	DESCRIPTION		PFU LIMITED		PAGE	46/140
DESIG	Jan. 9, 2009	K.Okada	CHECK	T.Anzai		APPR.	IFujioka			

4.4.12 Motor Fuse Blown

Item No.	Check items	Answer	How/where to check
1	Unplug the AC cable and plug it again. Is the problem solved?	Yes	End.
		No	Proceed to No.2.
2	Check to see if there is conductive substance in the Analog PCA (Refer to Section 5.8). Is there any foreign substances?	Yes	Proceed to No.3.
		No	Remove the foreign substance. Then replace the Analog PCA. (Refer to Section 5.7.)
3	Check to see if the cable between the Analog PCA and the Motor is not damaged. Check to see if the connector of above cable is connected properly (Refer to Section 5.7.5). Is the problem solved?	Yes	Proceed to No.4.
		No	Connect it without fail. If necessary, replace the Motor. (Refer to Section 5.10.3.)
4	Replace the Motor (Refer to Section 5.7.5). Is the problem solved?	Yes	End
		No	Replace the Analog PCA (Refer to Section 5.7.)

4.4.13 Operator Panel Alarm

Item No.	Check items	Answer	How/where to check
1	Unplug the Power cable and plug it again. Is the problem solved?	Yes	End.
		No	The Panel PCA does not have EEPROM data. This Panel PCA has been used before (not brand-new one) and might be replaced due to Operator Panel Alarm. Install a new Panel PCA. (Refer to Section 5.11.2.)

4.4.14 EEPROM Alarm

Item No.	Check items	Answer	How/where to check
1	Unplug the Power cable and plug it again. Is the problem solved?	Yes	End.
		No	Proceed to No.2.
2	Replace the Panel PCA and check to see if the problem is solved.	Yes	End.
		No	Replace the Control PCA and the Analog PCA. (Refer to Section 5.7.)

4.4.15 Image Memory Alarm, RAM Alarm, USB Control Chip Alarm

Item No.	Check items	Answer	How/where to check
1	Unplug the Power cable and plug it again. Is the problem solved?	Yes	End.
		No	Replace the Control PCA and the Analog PCA. (Refer to Section 5.7.)

4.4.16 Data Transfer Error Occurred

Item No.	Check items	Answer	How/where to check
1	Close the ADF Paper Chute to turn the scanner OFF. After two seconds or more, open the ADF Paper Chute to turn the scanner ON and scan the documents. Is the problem solved?	Yes	End.
		No	Replace the Control PCA and the Analog PCA. (Refer to Section 5.7.)

						TITLE	ScanSnap S1500/S1500-SR/S1500M MAINTENANCE MANUAL			
						DRAW. No.	P1PA03586-B00X/6		CUST.	
02	Jan. 23, 2009	K.Okada	T.Anzai	IFujioka	Refer to Revision Record on page 2.					
Rev	DATE	DESIG.	CHECK	APPR.	DESCRIPTION			PFU LIMITED	PAGE	47/140
DESIG	Jan. 9, 2009	K.Okada	CHECK	T.Anzai		APPR.	IFujioka			

4.4.17 US Sensor Alarm

Item No.	Check items	Answer	How/where to check
1	Unplug the Power cable and plug it again. Is the problem solved?	Yes	End.
		No	Proceed to No.2.
2	Check to see if the cable between the Analog PCA and the US Sensor F is not damaged and the connector of above cable is connected properly. (Refer to Section 5.10.7.)	Yes	Proceed to No.3.
		No	Connect it without fail.
3	Replace the Analog PCA and check to see if the problem is solved. (Refer to Section 5.7.)	Yes	End.
		No	Replace the US Sensor F. (Refer to Section 5.10.7.)

						TITLE	ScanSnap S1500/S1500-SR/S1500M MAINTENANCE MANUAL		
						DRAW. No.	P1PA03586-B00X/6	CUST.	
02	Jan. 23, 2009	K.Okada	T.Anzai	IFujioka	Refer to Revision Record on page 2.	PFU LIMITED		PAGE	48/140
Rev	DATE	DESIG.	CHECK	APPR.	DESCRIPTION				
DESIG	Jan. 9, 2009	K.Okada	CHECK	T.Anzai		APPR.	IFujioka		

Chapter 5 Maintenance Procedure

This chapter describes how to replace maintenance parts, and how to clean assemblies that end users cannot clean. When assembling the maintenance parts, conduct necessary cleaning when instructed.

The replacement procedures in this Chapter are explained with the ScanSnap S1500M.

The colors of some parts for S1500 are not the same with those for S1500M.

5.1 For Safety Operation

Please read this page carefully before disassembling or assembling.



Electric shock

Before disassembling or assembling, turn the power switch off, and unplug the Power cable from the outlet.

Otherwise, an electric shock may occur.



Injury

Be careful not to get your fingers, hair, clothes or accessories caught in a moving part.

It may cause injury.

Machine damage

Static Electricity may cause the damage to the ScanSnap.

When repairing the ScanSnap, wear a wrist strap to avoid ESD.

Notes when cleaning

When cleaning the ScanSnap, be careful not to allow foreign matter, such as dried ink and toner, to fall inside the ScanSnap.

How to unlock plastic hooks

Many parts of the ScanSnap are held in place with plastic hooks.

When removing parts that are held in place with these hooks, be very careful not to break the hooks.

Pull out the hook to unlock, and then pull up on the assembly to remove.



Do not use excessive force when removing parts held in place with these hooks.

5.2 Preventive Maintenance

Preventive maintenance is recommended on the ScanSnap at the following intervals.

Item	Maintenance cycle
Periodic maintenance	Every 12 months

During maintenance, clean the following areas if they are dirty.

- ADF (Refer to Section 7.2.3.)
- Optical Unit (Refer to Section 5.3.1.)

						TITLE	ScanSnap S1500/S1500-SR/S1500M MAINTENANCE MANUAL			
						DRAW. No.	P1PA03586-B00X/6		CUST.	
Rev	DATE	DESIG.	CHECK	APPR.	DESCRIPTION	PFU LIMITED			PAGE	49/140
02	Jan. 23, 2009	K.Okada	T.Anzai	IFujioka	Refer to Revision Record on page 2.					
DESIG	Jan. 9, 2009	K.Okada	CHECK	T.Anzai		APPR.	IFujioka			

5.3 Cleaning Maintenance Parts

This section describes how to clean the following maintenance part.

5.3.1 Optical Unit

- (1) Remove the Optical Unit by referring to Section 5.10.2 (for front side scanning) or Section 5.11.3 (for backside scanning)
- (2) Clean the mirrors inside of the Optical Unit with soft dry lint-free cloth or blow brush. Be sure that no fabric from the cloth remains on the mirrors.



- (3) Assemble the Optical Unit by following the procedure in reverse.

NOTICE

1. Be sure to use blow brush or dry lint-free cloth. Wiping the mirrors with alcohol may leave residue.
2. Reflective surface of the mirror (aluminum evaporated surface) is inside of the Optical Unit.
3. Cleaning should be done at where there is less dust.
4. Never remove the mirror section from the Optical Unit.

						TITLE	ScanSnap S1500/S1500-SR/S1500M MAINTENANCE MANUAL		
						DRAW. No.	P1PA03586-B00X/6		CUST.
02	Jan. 23, 2009	K.Okada	T.Anzai	IFujioka	Refer to Revision Record on page 2.				
Rev	DATE	DESIG.	CHECK	APPR.	DESCRIPTION	PFU LIMITED		PAGE	50/140
DESIG	Jan. 9, 2009	K.Okada	CHECK	T.Anzai		APPR.	IFujioka		

5.4 Maintenance Tool

Special tools to maintain this ScanSnap are shown in table 5.4.

Table 5.4: Maintenance Tool List

No.	Tools	When to use	Remarks
1	Philips screwdriver		For M3 screws
2	Alcohol	Cleaning	Isopropyl alcohol
3	Blow brush	Cleaning mirrors	
4	Small flat-blade screwdriver	Removing sensors and connectors	
5	Test chart No.42	Used to adjust or confirm the image in Section 6.6.	Part number: PA03277-Y120 Purchase this sheet prior to maintenance. Refer to figure 1. (Note 1)
6	Test sheet (W)	Used to adjust or confirm the image in Section 6.6.	Part number: PA03277-Y123 Purchase this sheet prior to maintenance. Refer to figure 2. (Note 1, 2)
7	Tester	Measuring voltage Checking conduction	
8	Spring gauge	Adjusting belt tension	

Note 1: Replace with the new one if used more than approximately 200 times for adjustments, or if adjustment errors frequently occur because of smear.

Note 2: Avoid direct sunlight when storing.

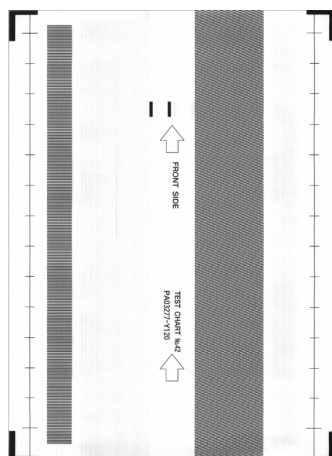

Figure 1 Test chart No.42



Figure 2 Test sheet (W)

						TITLE	ScanSnap S1500/S1500-SR/S1500M MAINTENANCE MANUAL			
						DRAW. No.	P1PA03586-B00X/6	CUST.		
02	Jan. 23, 2009	K.Okada	T.Anzai	IFujioka	Refer to Revision Record on page 2.					
Rev	DATE	DESIG.	CHECK	APPR.	DESCRIPTION			PFU LIMITED	PAGE	51/140
DESIG	Jan. 9, 2009	K.Okada	CHECK	T.Anzai	APPR.	IFujioka				

5.5 Non-disassembly Parts

⚠ CAUTION

The following screws are adjusted and secured at the factory. Do NOT attempt to disassemble or loosen them to avoid critical damage in the image.

- (1) Optical Unit
 - CCD board fixing screws
 - Mirror section

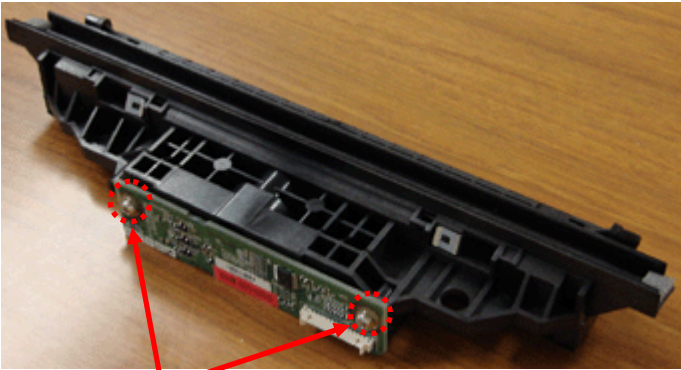

CCD board fixing screw (x2)

						TITLE	ScanSnap S1500/S1500-SR/S1500M MAINTENANCE MANUAL		
						DRAW. No.	P1PA03586-B00X/6		CUST.
02	Jan. 23, 2009	K.Okada	T.Anzai	IFujioka	Refer to Revision Record on page 2.				
Rev	DATE	DESIG.	CHECK	APPR.	DESCRIPTION			PFU LIMITED	PAGE 52/140
DESIG	Jan. 9, 2009	K.Okada	CHECK	T.Anzai		APPR.	IFujioka		

5.6 Replacing LIDCOV ASSY / Guide P ASSY / Stacker ASSY / Chute ASSY

5.6.1 LIDCOV ASSY

NOTICE

Refer to Section 3.2.19 for the part number of the LIDCOV ASSY.

<Removal>

Unlatch the left and right joints (circles below) of the LIDCOV ASSY by bowing the center of the LIDCOV ASSY, and remove the LIDCOV ASSY.

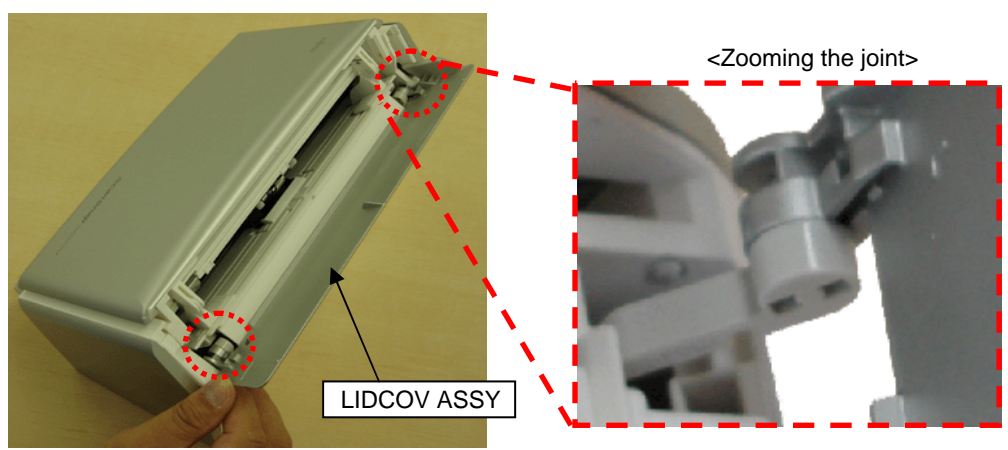

<Installation>

Follow the above procedure in reverse order.

						TITLE	ScanSnap S1500/S1500-SR/S1500M MAINTENANCE MANUAL		
						DRAW. No.	P1PA03586-B00X/6		CUST.
02	Jan. 23, 2009	K.Okada	T.Anzai	IFujioka	Refer to Revision Record on page 2.				
Rev	DATE	DESIG.	CHECK	APPR.	DESCRIPTION			PFU LIMITED	PAGE 53/140
DESIG	Jan. 9, 2009	K.Okada	CHECK	T.Anzai		APPR.	IFujioka		

5.6.2 Guide P ASSY

NOTICE

Refer to Section 3.2.18 for the part number of the Guide P ASSY.

<Removal>

- (1) Open the ADF Top Section. (Refer to Section 7.1.2.)
- (2) Adjust the side guides to the "A5" size.

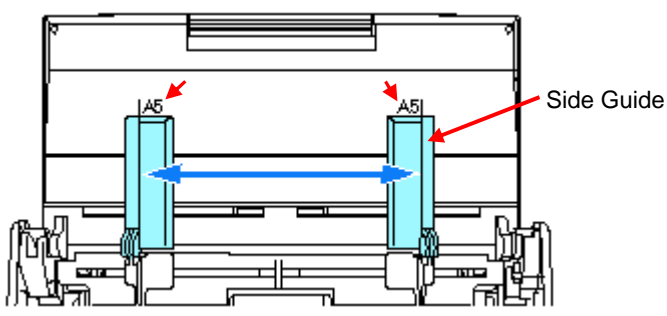

- (3) Hold the pickup tabs on the Guide P ASSY between the thumb and index finger, and then pull up the Guide P ASSY to remove.

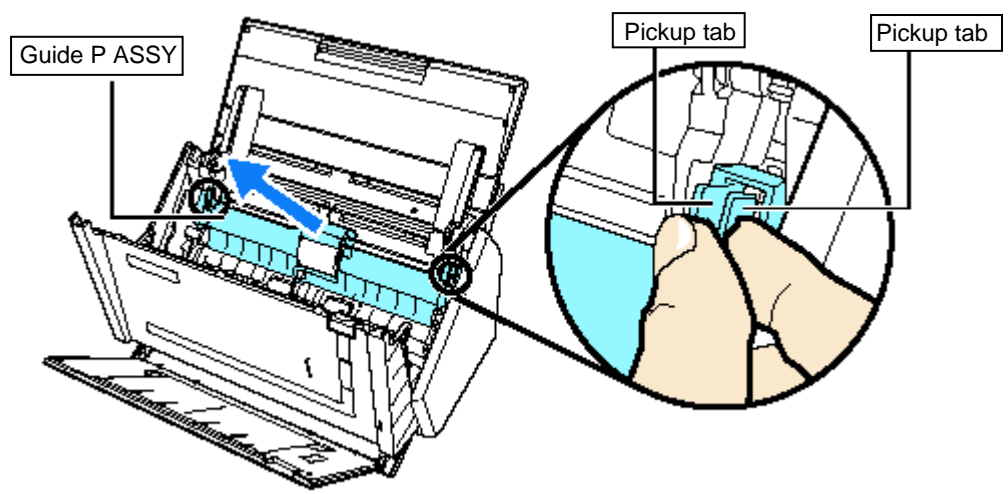

<Installation>

Follow the above procedure in reverse order.

						TITLE	ScanSnap S1500/S1500-SR/S1500M MAINTENANCE MANUAL		
						DRAW. No.	P1PA03586-B00X/6	CUST.	
02	Jan. 23, 2009	K.Okada	T.Anzai	IFujioka	Refer to Revision Record on page 2.				
Rev	DATE	DESIG.	CHECK	APPR.	DESCRIPTION				
DESIG	Jan. 9, 2009	K.Okada	CHECK	T.Anzai	APPR.	IFujioka	PFU LIMITED		PAGE 54/140

5.6.3 Stacker ASSY

NOTICE

Refer to Section 3.2.23 for the part number of Stacker ASSY.

<Removal>

- (1) Open the ADF Paper Chute, then the Stacker.

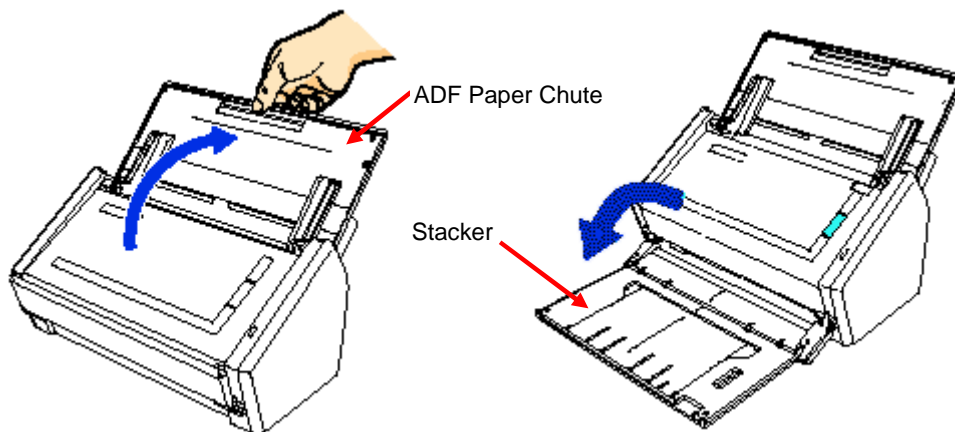

- (2) Bowing the center of the Stacker ASSY, pull the pin at the right side of the Stacker ASSY out of the mounting hole to remove the Stacker ASSY.

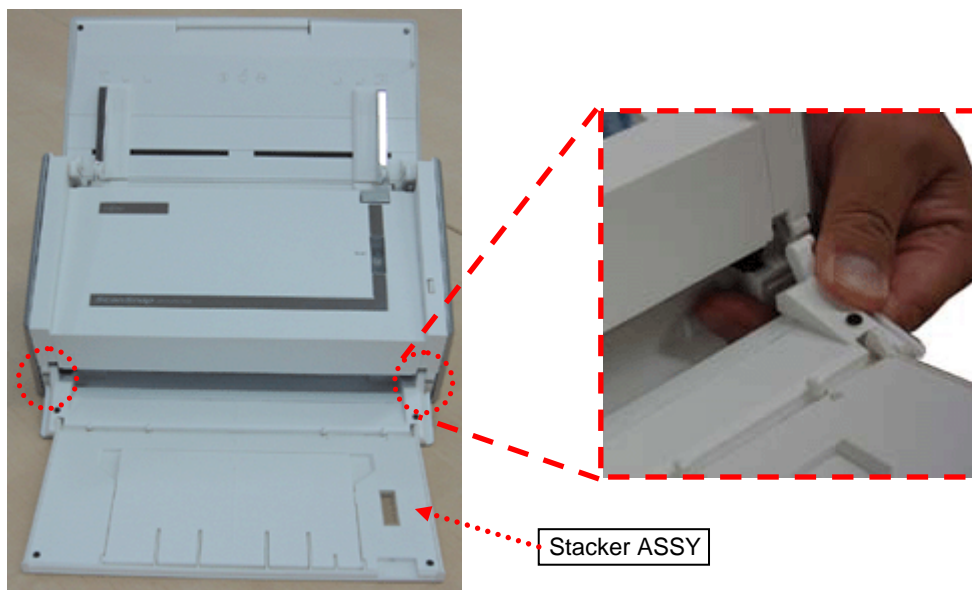

<Installation>

Follow the above procedure in reverse order.

						TITLE	ScanSnap S1500/S1500-SR/S1500M MAINTENANCE MANUAL		
						DRAW. No.	P1PA03586-B00X/6	CUST.	
02	Jan. 23, 2009	K.Okada	T.Anzai	IFujioka	Refer to Revision Record on page 2.				
Rev	DATE	DESIG.	CHECK	APPR.	DESCRIPTION			PFU LIMITED	
DESIG	Jan. 9, 2009	K.Okada	CHECK	T.Anzai	APPR.	IFujioka	PAGE	55/140	

5.6.4 Chute ASSY

NOTICE

Refer to Section 3.2.22 for the part number of the Chute ASSY.

<Removal>

- (1) Remove the LIDCOV ASSY. (Refer to Section 5.6.1.)
- (2) Open the ADF Top Section. (Refer to Section 7.1.2.)
- (3) Remove the Guide P ASSY. (Refer to Section 5.6.2.)
- (4) Unlatch two claws at right and left sides of the Chute ASSY from the rear of the ScanSnap to open the part A in the photo below.

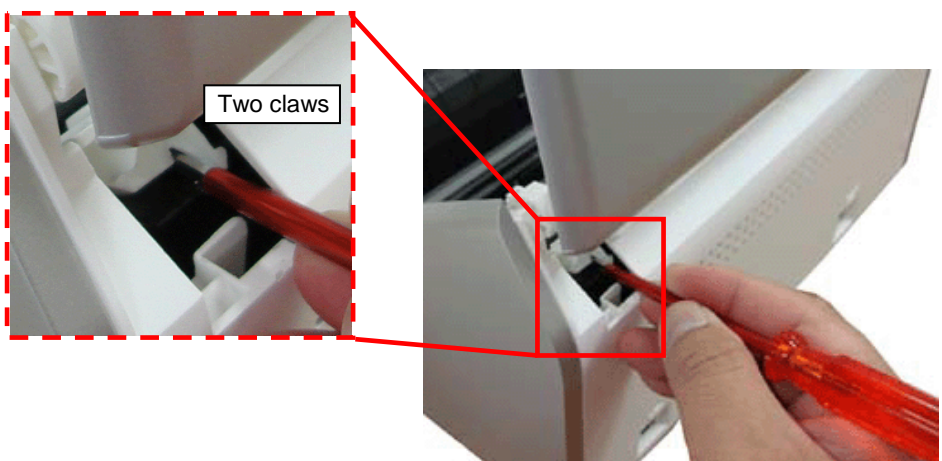

- (5) Remove the right and left pivots of the Chute ASSY one by one by opening the Base Cover ASSY a bit. 

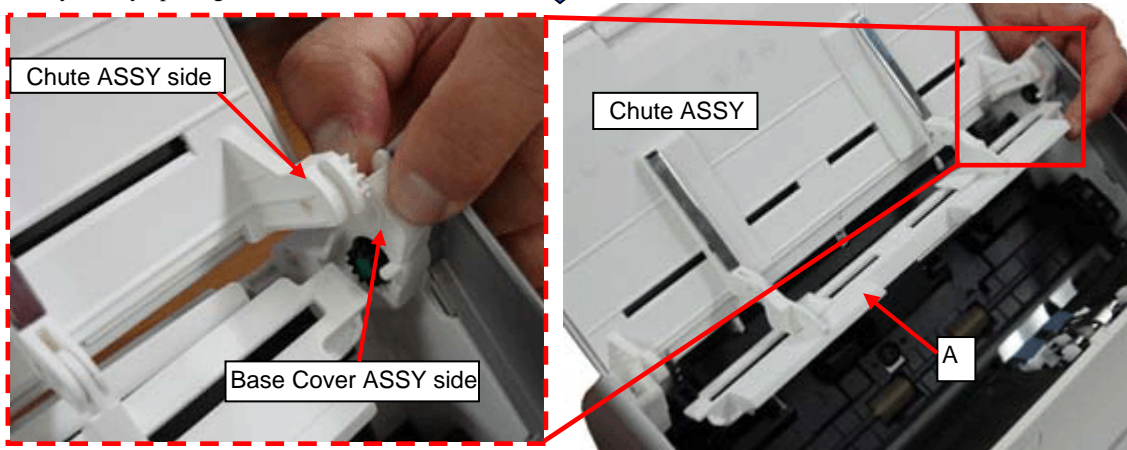

<Installation>

Follow the above procedure in reverse order.

						TITLE	ScanSnap S1500/S1500-SR/S1500M MAINTENANCE MANUAL		
						DRAW. No.	P1PA03586-B00X/6	CUST.	
02	Jan. 23, 2009	K.Okada	T.Anzai	IFujioka	Refer to Revision Record on page 2.				
Rev	DATE	DESIG.	CHECK	APPR.	DESCRIPTION	PFU LIMITED		PAGE	56/140
DESIG	Jan. 9, 2009	K.Okada	CHECK	T.Anzai	APPR.	IFujioka			

- (4) Remove three screws A and one screw B that secure the Control PCA and the Analog PCA, and remove two PCA's from the PCA Cover.

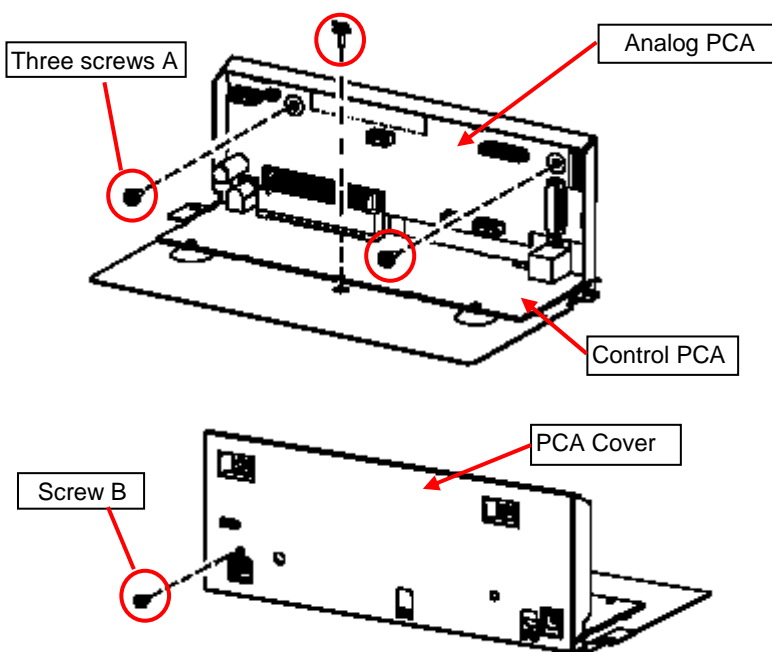

- (5) Disconnect the connector that joins the two PCA's, and separate the Control PCA and the Panel PCA.

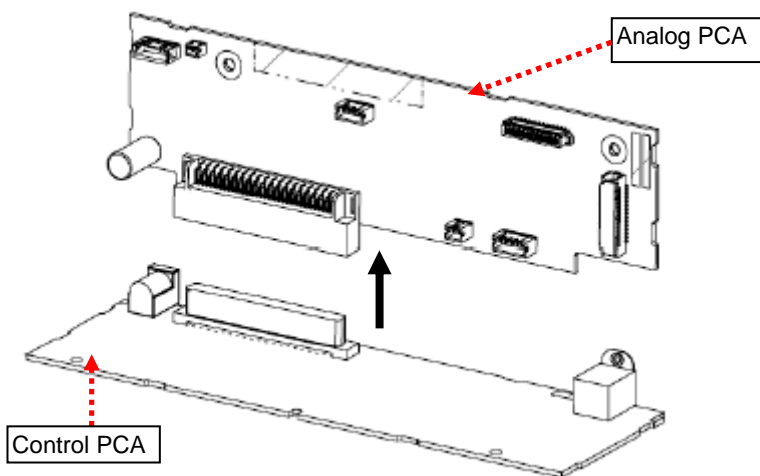

<Installation>

Follow the above procedure in reverse order.

NOTICE

- Check that the connectors are securely connected.
- There are two types of screws. Do not attach the wrong screw.
- When installing the PCB-UNIT, if a wrong cable is connected, radio wave specification may not be satisfied. By referring to Section 5.14.2, be sure to connect the cables properly.

						TITLE	ScanSnap S1500/S1500-SR/S1500M MAINTENANCE MANUAL		
						DRAW. No.	P1PA03586-B00X/6	CUST.	
02	Jan. 23, 2009	K.Okada	T.Anzai	IFujioka	Refer to Revision Record on page 2.				
Rev	DATE	DESIG.	CHECK	APPR.	DESCRIPTION		PFU LIMITED	PAGE	58/140
DESIG	Jan. 9, 2009	K.Okada	CHECK	T.Anzai		APPR. IFujioka			

5.8 Replacing Guide A

NOTICE

Refer to Section 3.2.21 for the part number of the Guide A.

<Removal>

- (1) Remove the following parts.
 - PCA Unit: Steps (1) ~ (3) in Section 5.7
 - Guide P ASSY: Section 5.6.2
 - LIDCOV ASSY: Section 5.6.1
 - Chute ASSY: Section 5.6.4
 - Base Cover ASSY: Step (2) in Section 5.9
 - Stacker ASSY: Section 5.6.3
 - Top Cover ASSY: Steps (2) ~ (3) in Section 5.11.1

- (2) Unlatch the two claws at the right and left sides of the Guide A to remove the Guide A.

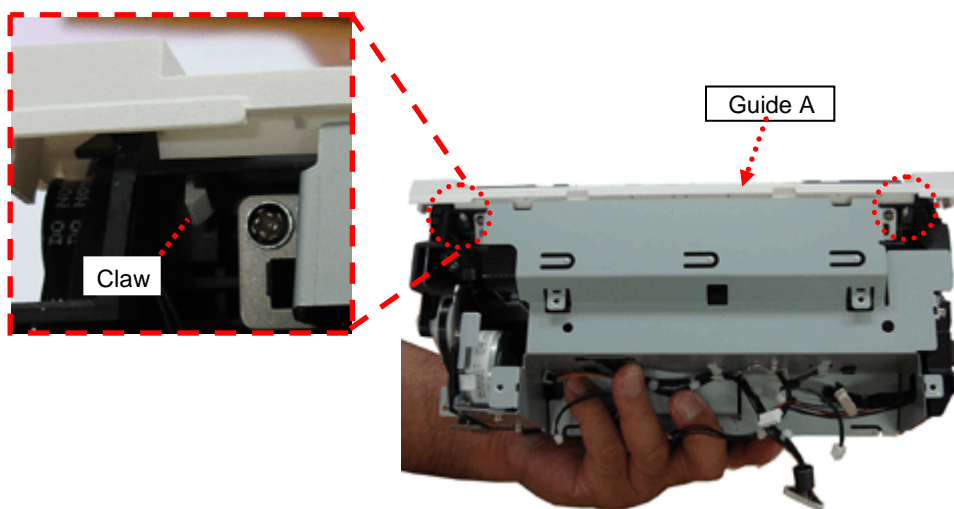

<Installation>

Follow the above procedure in reverse order.

- **When installing the PCB-UNIT, if a wrong cable is connected, radio wave specification may not be satisfied. By referring to Section 5.14.2, be sure to connect the cables properly.**

						TITLE	ScanSnap S1500/S1500-SR/S1500M MAINTENANCE MANUAL		
						DRAW. No.	P1PA03586-B00X/6	CUST.	
02	Jan. 23, 2009	K.Okada	T.Anzai	IFujioka	Refer to Revision Record on page 2.				
Rev	DATE	DESIG.	CHECK	APPR.	DESCRIPTION	PFU LIMITED		PAGE	59/140
DESIG	Jan. 9, 2009	K.Okada	CHECK	T.Anzai		APPR.	IFujioka		

5.9 Removing Base Cover ASSY and Replacing Torque-Dumper

NOTICE

The Base Cover ASSY is not a maintenance parts.
Refer to Section 3.2.20 for the part number of the Torque-Dumper.

<Removal>

- (1) Remove the following parts.
 - Guide P ASSY: Section 5.6.2
 - LIDCOV ASSY: Section 5.6.1
 - Chute ASSY: Section 5.6.4

- (2) Unlatch the two claws. Pull out the Base Cover ASSY backwards to remove.

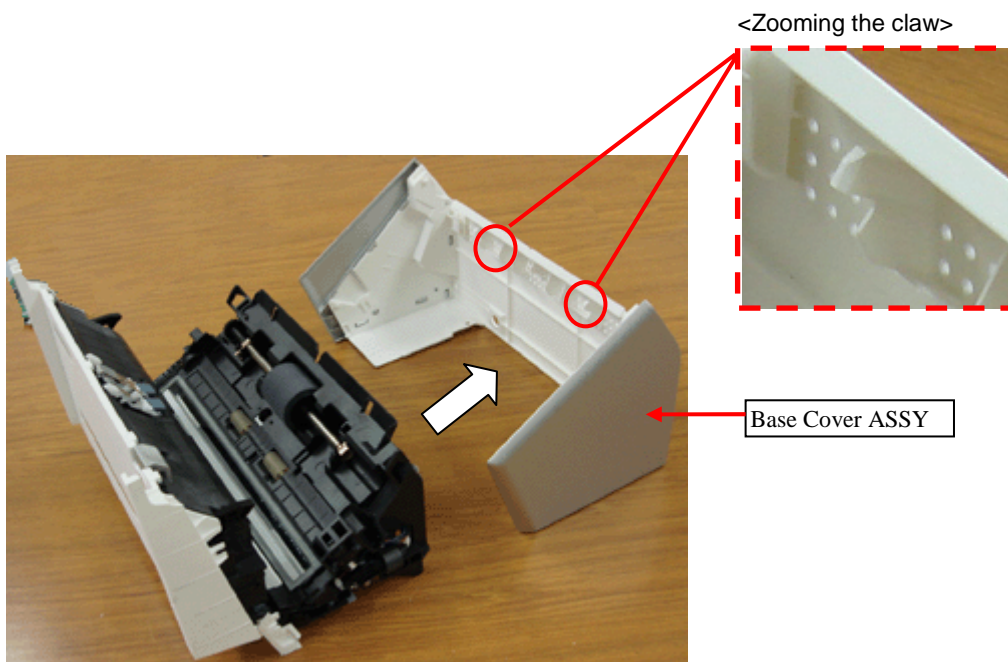

- (3) Remove the side cover (right) from the Base Cover ASSY.
Unlatch the four claws, and then remove the side cover (right) from the three hooks.

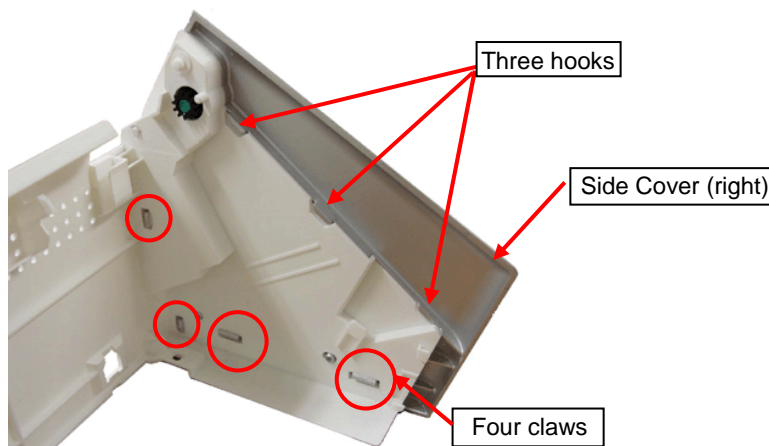

						TITLE	ScanSnap S1500/S1500-SR/S1500M MAINTENANCE MANUAL			
						DRAW. No.	P1PA03586-B00X/6	CUST.		
02	Jan. 23, 2009	K.Okada	T.Anzai	IFujioka	Refer to Revision Record on page 2.					
Rev	DATE	DESIG.	CHECK	APPR.	DESCRIPTION				PAGE	60/140
DESIG	Jan. 9, 2009	K.Okada	CHECK	T.Anzai	APPR.	IFujioka	PFU LIMITED			

(4) Remove two tapping screws to remove the Torque-Dumper.

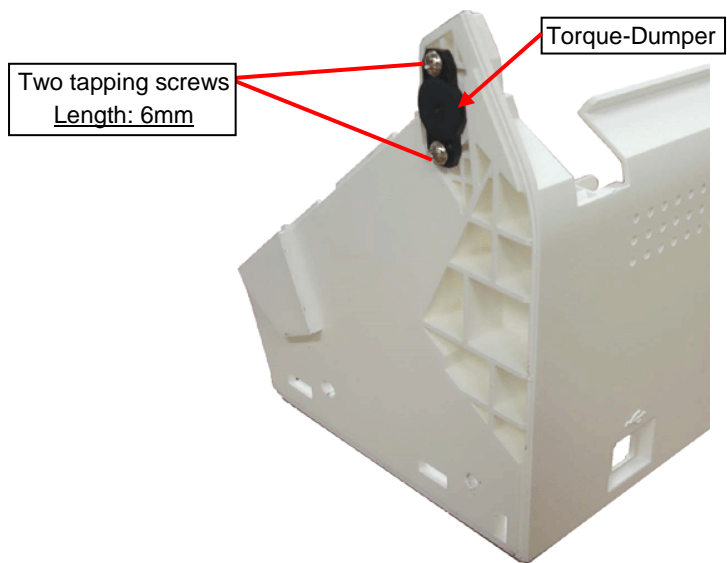

<Installation>

Follow the above procedure in reverse order.

NOTICE

- **When installing the PCB-UNIT, if a wrong cable is connected, radio wave specification may not be satisfied. By referring to Section 5.14.2, be sure to connect the cables properly.**

- When installing the Side Cover (right), latch the three upper hooks first, and then latch the four lower claws.

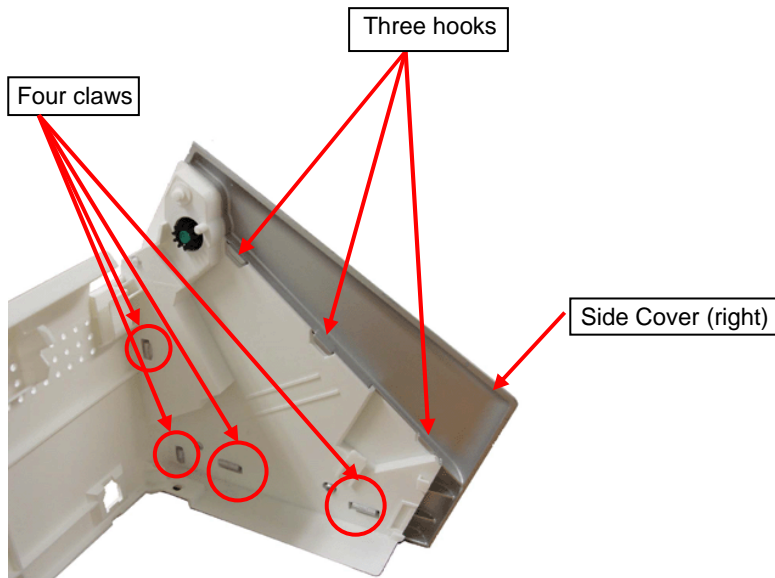

- Make sure that the two claws are securely inserted into the holes when installing the Base Cover ASSY.

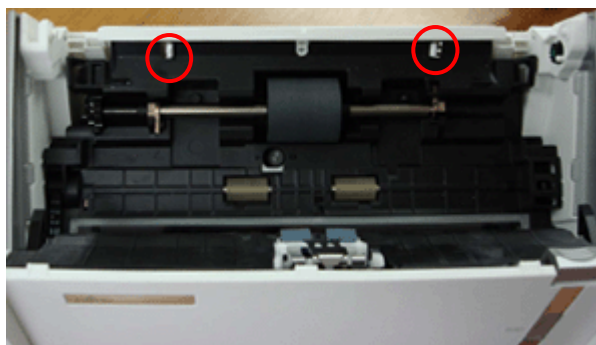

						TITLE	ScanSnap S1500/S1500-SR/S1500M MAINTENANCE MANUAL			
						DRAW. No.	P1PA03586-B00X/6	CUST.		
02	Jan. 23, 2009	K.Okada	T.Anzai	IFujioka	Refer to Revision Record on page 2.		PFU LIMITED		PAGE	61/140
Rev	DATE	DESIG.	CHECK	APPR.	DESCRIPTION		PFU LIMITED		PAGE	61/140
DESIG	Jan. 9, 2009	K.Okada	CHECK	T.Anzai		APPR.	IFujioka			

5.10 Replacing the Parts inside of Fixed Unit

5.10.1 Exit Roller / HK Ring

NOTICE

- Refer to the following Sections for the part number of the following maintenance parts:
Exit Roller: Section 3.2.15
HK Ring: Section 3.2.31
- Two HK Rings are mounted on the Exit Roller. Ignore step (7).

<Removal>

- (1) Remove the following parts.
 - PCA Unit: Steps (1) ~ (3) in Section 5.7
 - Guide P ASSY: Section 5.6.2
 - LIDCOV ASSY: Section 5.6.1
 - Chute ASSY: Section 5.6.4
 - Base Cover ASSY: Step (2) in Section 5.9
 - Stacker ASSY: Section 5.6.3
 - Top Cover ASSY: Steps (2) ~ (3) in Section 5.11.1
 - Guide A: Step (2) in Section 5.8
- (2) Loosen the adjusting screw, and then remove the Belt.

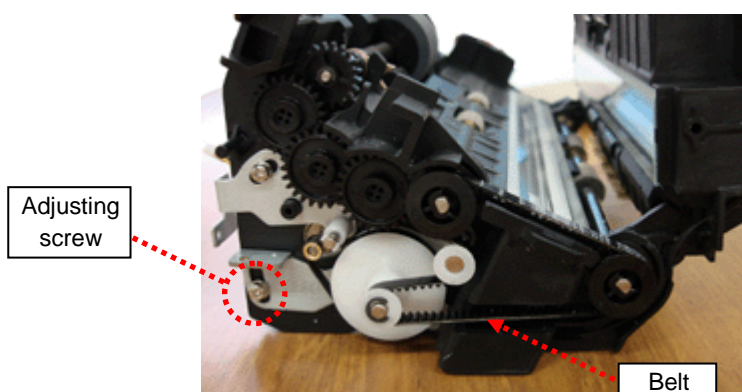

- (3) Unlatch the claw with a small flat-blade screwdriver, and then pull the pulley out of the Exit Roller shaft.

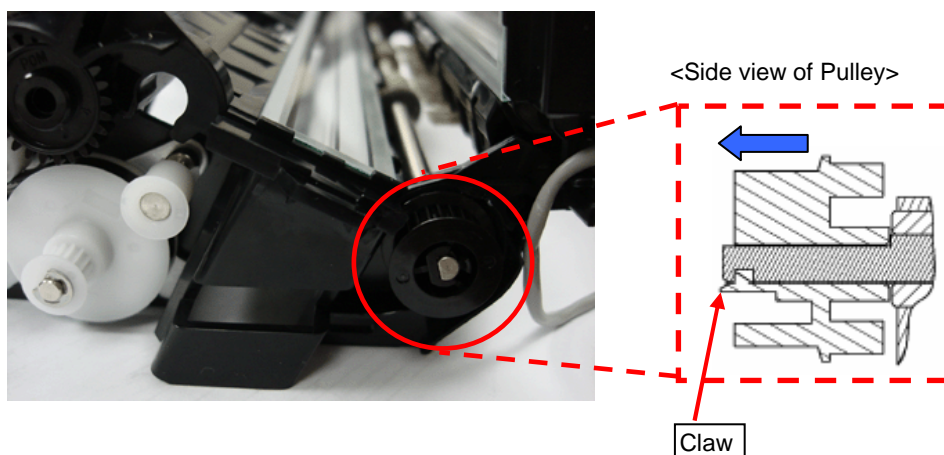

						TITLE	ScanSnap S1500/S1500-SR/S1500M MAINTENANCE MANUAL		
						DRAW. No.	P1PA03586-B00X/6	CUST.	
02	Jan. 23, 2009	K.Okada	T.Anzai	IFujioka	Refer to Revision Record on page 2.				
Rev	DATE	DESIG.	CHECK	APPR.	DESCRIPTION	PFU LIMITED		PAGE	62/140
DESIG	Jan. 9, 2009	K.Okada	CHECK	T.Anzai	APPR.	IFujioka			

(4) Remove the right and left bushings with a flat-blade screwdriver.

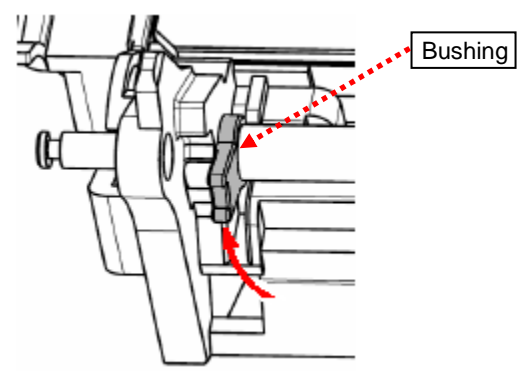

(5) Pull out the Exit Roller, and then remove the bushings at the both sides.

(6) When the Exit Roller is pulled out, remove the bushing.

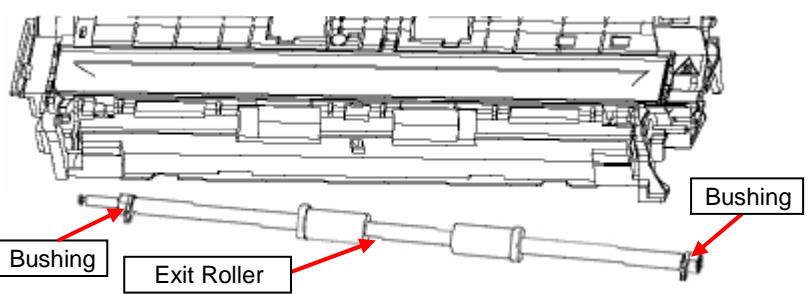

(7) Remove the bearings from the Exit Roller (only when replacing the HK Ring).

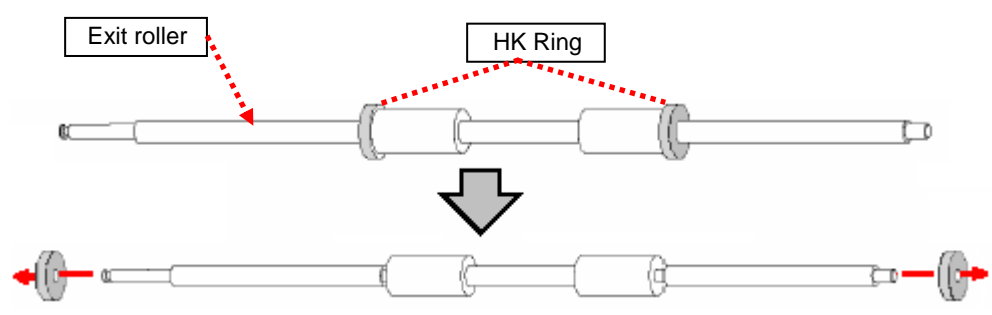

<Installation>

Follow the above procedure in reverse order.

NOTICE

Note the following points.

- Tack the pulley into the roller shaft, and then make sure that the pulley is locked.
- Pull the pulley, and then make sure that there is a thrust (gap) on the Exit Roller.
- When installing the PCB-UNIT, if a wrong cable is connected, radio wave specification may not be satisfied. By referring to Section 5.14.2, be sure to connect the cables properly.
- Tension adjustment is required with a spring gauge when installing the Belt (tightening the adjusting crew). (Refer to Section 5.13.)
- Set the belt at the external side of the pulley. Rotate the gear two or three times after installing the Belt. (Refer to the figure on the right.)
- After replacement, perform the image adjustment. (Refer to Section 6.6.)

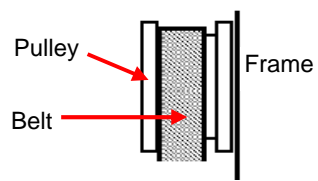

						TITLE	ScanSnap S1500/S1500-SR/S1500M MAINTENANCE MANUAL		
						DRAW. No.	P1PA03586-B00X/6	CUST.	
02	Jan. 23, 2009	K.Okada	T.Anzai	IFujioka	Refer to Revision Record on page 2.				
Rev	DATE	DESIG.	CHECK	APPR.	DESCRIPTION				
DESIG	Jan. 9, 2009	K.Okada	CHECK	T.Anzai	APPR.	IFujioka	PFU LIMITED		PAGE 63/140

5.10.2 Optical Unit (for front side scanning)

NOTICE

Refer to Section 3.2.4 for the part number of Optical Unit.

<Removal>

- (1) Remove the following parts.
 - PCA Unit: Steps (1) ~ (3) in Section 5.7
 - Guide P ASSY: Section 5.6.2
 - LIDCOV ASSY: Section 5.6.1
 - Chute ASSY: Section 5.6.4
 - Base Cover ASSY: Step (2) in Section 5.9

- (2) Remove the shield cover.
 - a) Remove the screw that secures the FG Cable from the side of the Fixed Unit.

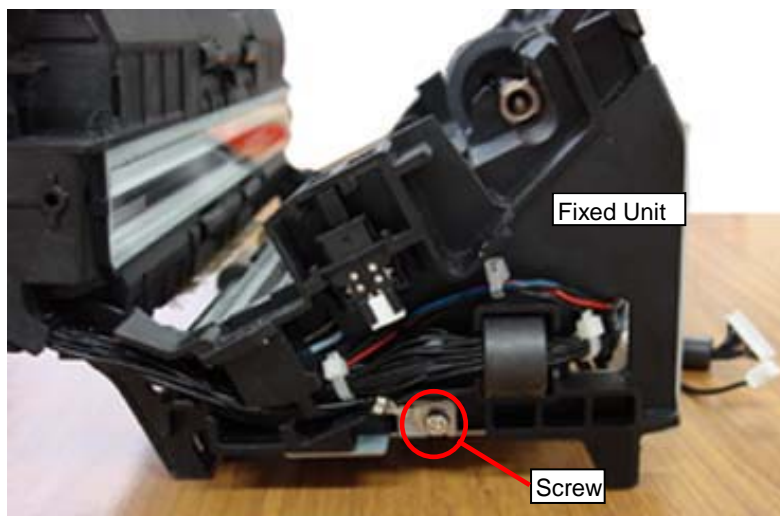

- b) Remove a tapping screw and a screw, and then remove the two FG Cables that are fixed to the shield cover.

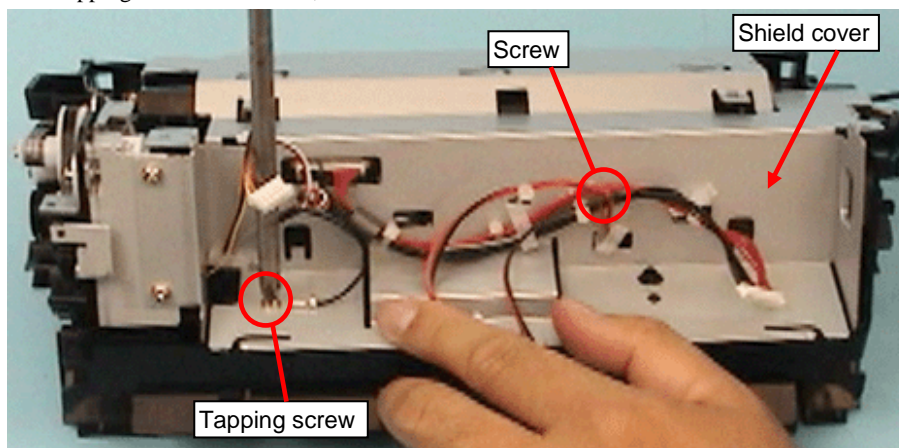

						TITLE	ScanSnap S1500/S1500-SR/S1500M MAINTENANCE MANUAL			
						DRAW. No.	P1PA03586-B00X/6	CUST.		
02	Jan. 23, 2009	K.Okada	T.Anzai	IFujioka	Refer to Revision Record on page 2.					
Rev	DATE	DESIG.	CHECK	APPR.	DESCRIPTION		PFU LIMITED		PAGE	64/140
DESIG	Jan. 9, 2009	K.Okada	CHECK	T.Anzai		APPR.	IFujioka			

c) Remove all the cables from the four cable clamps on the shield cover.

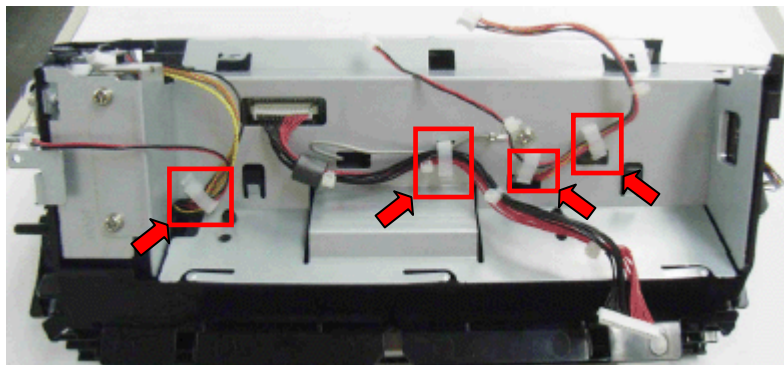

d) Remove two screws and two tapping screws.

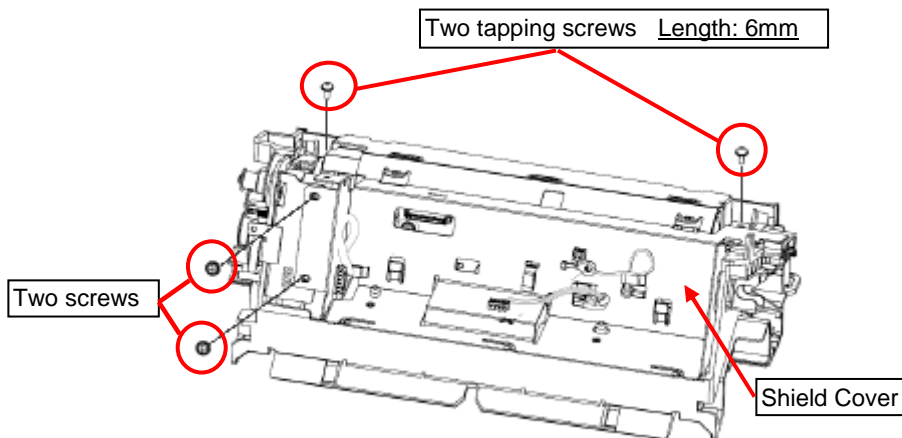

e) Remove the shield cover while disconnecting the five cables.

NOTICE

When pulling the cables out of the shield cover (red marks in the figure below), be careful not to damage them.

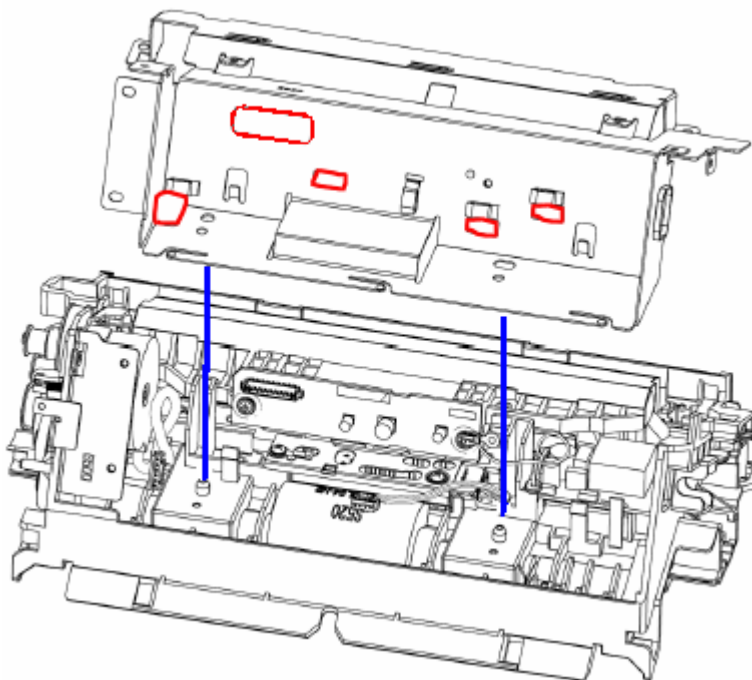

						TITLE	ScanSnap S1500/S1500-SR/S1500M MAINTENANCE MANUAL		
						DRAW. No.	P1PA03586-B00X/6	CUST.	
02	Jan. 23, 2009	K.Okada	T.Anzai	IFujioka	Refer to Revision Record on page 2.				
Rev	DATE	DESIG.	CHECK	APPR.	DESCRIPTION				
DESIG	Jan. 9, 2009	K.Okada	CHECK	T.Anzai	APPR.	IFujioka	PFU LIMITED		PAGE 65/140

- (3) Disconnect one connector from the Optical Unit to remove.
- (4) Unlatch the two claws on the Fixed Unit. Unhook the Optical Unit to remove.

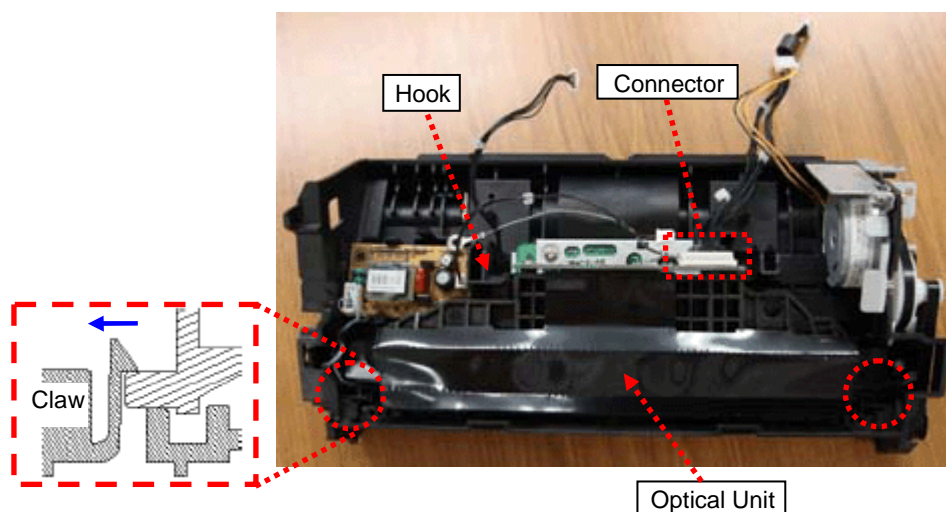

<Installation>

Follow the above procedure in reverse order.

NOTICE

Note the following points.

- When installing the shield plate, if wrong cables or clamps are allocated, radio wave specifications may not be satisfied. By referring to Section 5.14.1, be sure to allocate the cables and clamps properly.
- When installing the PCB-UNIT, if a wrong cable is connected, radio wave specification may not be satisfied. By referring to Section 5.14.2, be sure to connect the cables properly.
- Do not use the wrong type of screw.
- Check that the two claws on the Fixed Unit are securely hooked on the Optical Unit.

After replacement, perform the image adjustment. (Refer to Section 6.6.)

						TITLE	ScanSnap S1500/S1500-SR/S1500M MAINTENANCE MANUAL		
						DRAW. No.	P1PA03586-B00X/6	CUST.	
02	Jan. 23, 2009	K.Okada	T.Anzai	IFujioka	Refer to Revision Record on page 2.				
Rev	DATE	DESIG.	CHECK	APPR.	DESCRIPTION		PFU LIMITED	PAGE	66/140
DESIG	Jan. 9, 2009	K.Okada	CHECK	T.Anzai		APPR. IFujioka			

5.10.3 Motor

NOTICE

Refer to Section 3.2.11 for the part number of Motor.

<Removal>

- (1) Remove the following parts.
 - PCA Unit: Steps (1) ~ (3) in Section 5.7
 - Guide P ASSY: Section 5.6.2
 - LIDCOV ASSY: Section 5.6.1
 - Chute ASSY: Section 5.6.4
 - Base Cover ASSY: Step (2) in Section 5.9
 - Stacker ASSY: Section 5.6.3

- (2) Remove the shield cover. (Refer to steps (2) and (3) on Section 5.10.2.)
- (3) Remove the belt A, belt B and the adjusting bracket A.
 - a) Loosen the adjusting screw A, and then remove the belt A.
 - b) Remove the adjusting screw B, and then remove the adjusting bracket B and belt B.

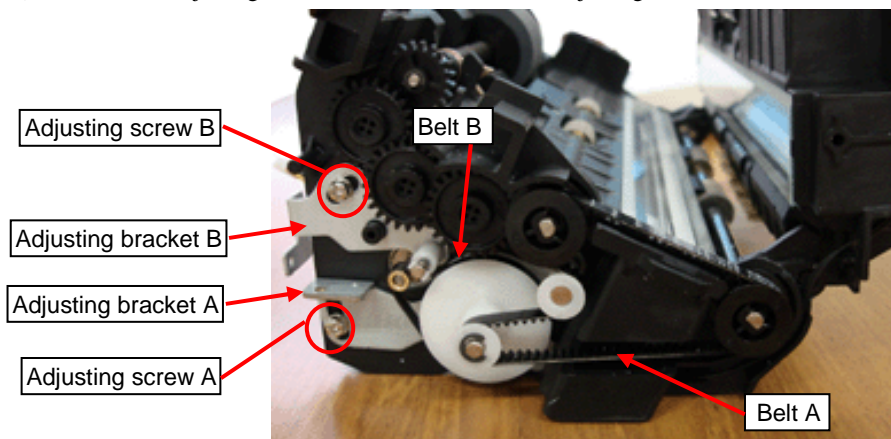

- (4) Remove the E-ring to remove the pulley.

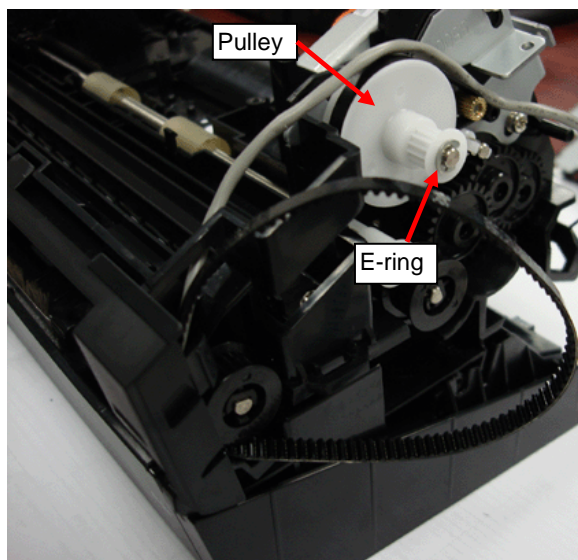

						TITLE	ScanSnap S1500/S1500-SR/S1500M MAINTENANCE MANUAL		
						DRAW. No.	P1PA03586-B00X/6		CUST.
02	Jan. 23, 2009	K.Okada	T.Anzai	IFujioka	Refer to Revision Record on page 2.				
Rev	DATE	DESIG.	CHECK	APPR.	DESCRIPTION			PFU LIMITED	PAGE 67/140
DESIG	Jan. 9, 2009	K.Okada	CHECK	T.Anzai		APPR.	IFujioka		

(5) Remove the remaining fixing screw to remove the Motor.

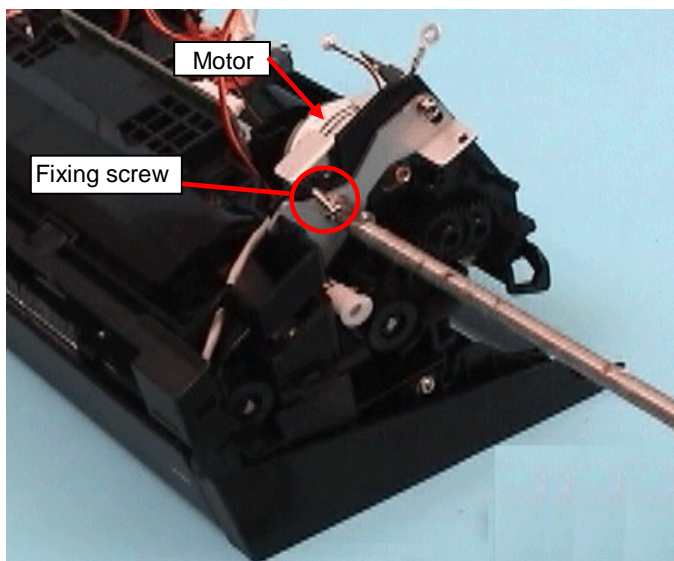

<Installation>

Follow the above procedure in reverse order.

NOTICE

Note the following points.

- Tension adjustment is required with a spring gauge when installing the Belt (tightening the adjusting crew). (Refer to Section 5.13.)
- Set the belt external side of the pulley. Rotate the gear two or three times after installing the Belt.
- When installing the shield plate, if wrong cables or clamps are allocated, radio wave specifications may not be satisfied. By referring to Section 5.14.1, be sure to allocate the cables and clamps properly.
- When installing the PCB-UNIT, if a wrong cable is connected, radio wave specification may not be satisfied. By referring to Section 5.14.2, be sure to connect the cables properly.

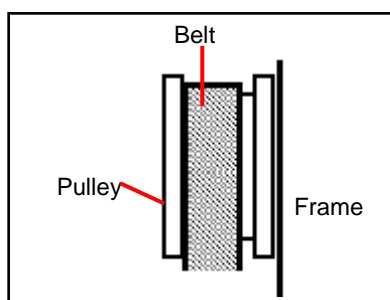

						TITLE	ScanSnap S1500/S1500-SR/S1500M MAINTENANCE MANUAL		
						DRAW. No.	P1PA03586-B00X/6	CUST.	
02	Jan. 23, 2009	K.Okada	T.Anzai	IFujioka	Refer to Revision Record on page 2.				
Rev	DATE	DESIG.	CHECK	APPR.	DESCRIPTION			PFU LIMITED	PAGE 68/140
DESIG	Jan. 9, 2009	K.Okada	CHECK	T.Anzai		APPR.	IFujioka		

5.10.4 Lamp (for front side scanning)

NOTICE

Refer to Section 3.2.2 for the part number of Lamp.

<Removal>

- (1) Remove the following parts.
 - PCA Unit: Steps (1) ~ (3) in Section 5.7
 - Guide P ASSY: Section 5.6.2
 - LIDCOV ASSY: Section 5.6.1
 - Chute ASSY: Section 5.6.4
 - Base Cover ASSY: Step (2) in Section 5.9
 - Optical Unit: Steps (2) ~ (5) in Section 5.10.2
- (2) Disconnect the connector for the Lamp connected to the Inverter.
- (3) Remove the two tapping screws that secure the reflector to remove the reflector.

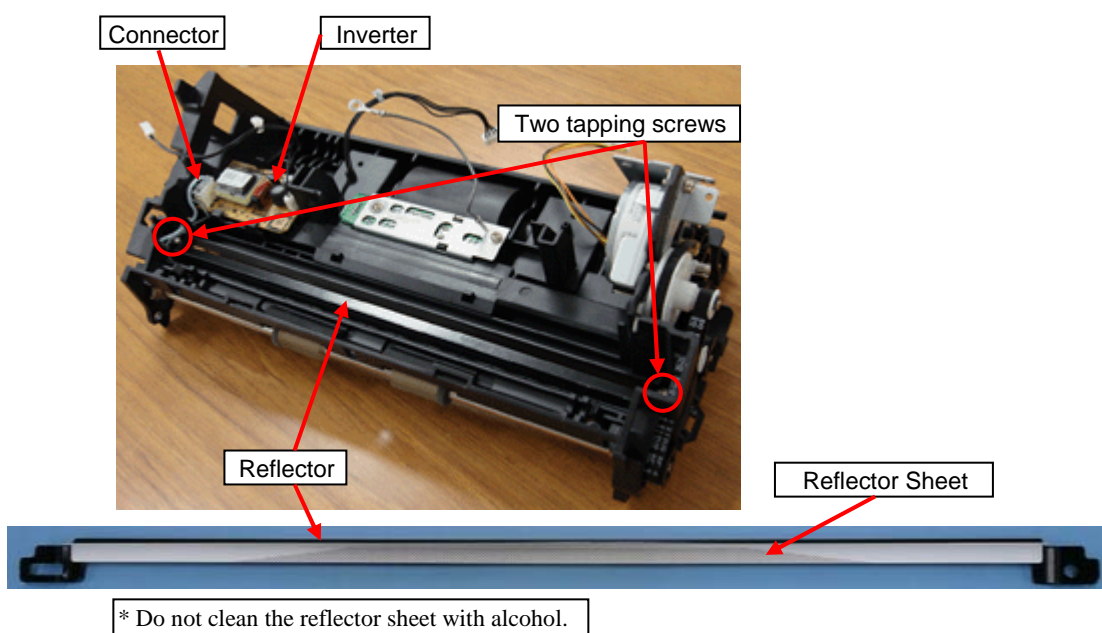

- (4) Remove the Lamp from the frame on the Fixed Unit.

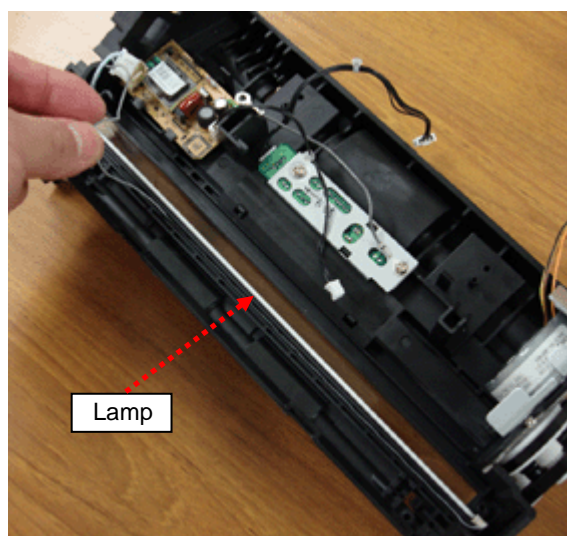

						TITLE	ScanSnap S1500/S1500-SR/S1500M MAINTENANCE MANUAL			
						DRAW. No.	P1PA03586-B00X/6	CUST.		
02	Jan. 23, 2009	K.Okada	T.Anzai	IFujioka	Refer to Revision Record on page 2.					
Rev	DATE	DESIG.	CHECK	APPR.	DESCRIPTION		PFU LIMITED		PAGE	69/140
DESIG	Jan. 9, 2009	K.Okada	CHECK	T.Anzai		APPR.	IFujioka			

<Installation>

Follow the above procedure in reverse order.

NOTICE

Note the following points.

- Bump the edge of the Lamp into the Fixed frame.
- Insert the reflector sheet between the Lamp and the frame.
- When installing the shield plate, if wrong cables or clamps are allocated, radio wave specifications may not be satisfied. By referring to Section 5.14.1, be sure to allocate the cables and clamps properly.
- When installing the PCB-UNIT, if a wrong cable is connected, radio wave specification may not be satisfied. By referring to Section 5.14.2, be sure to connect the cables properly.

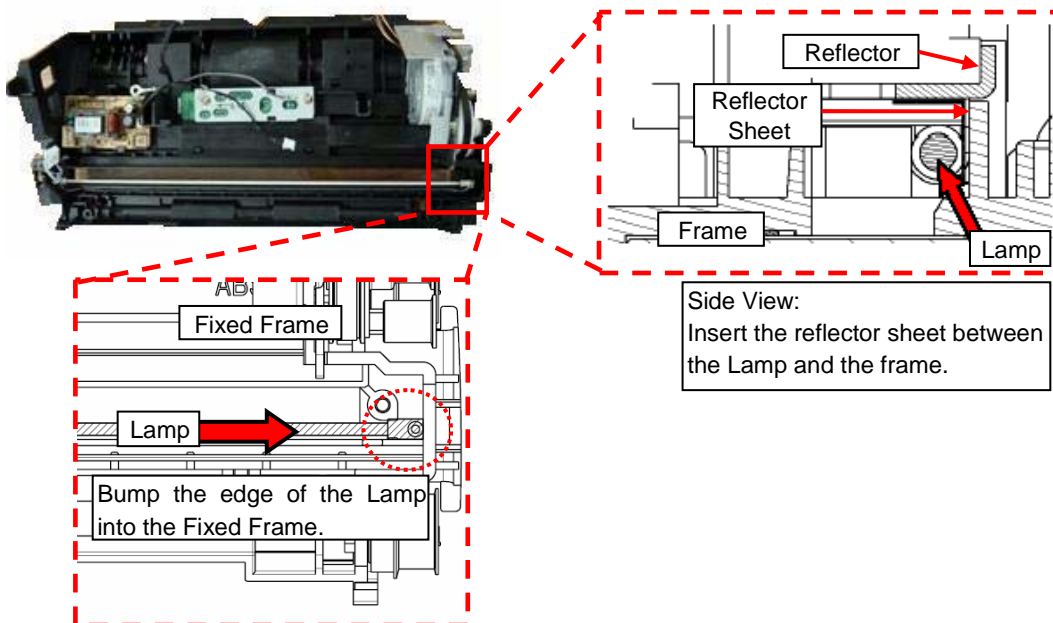

- Place the Lamp cables as shown in the photos below.

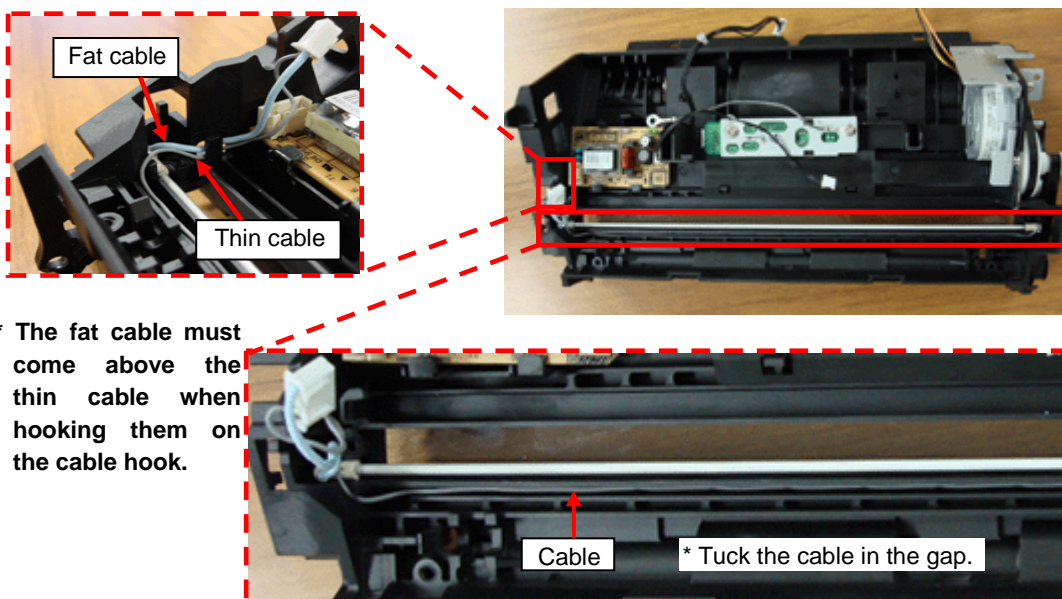

* The fat cable must come above the thin cable when hooking them on the cable hook.

						TITLE	ScanSnap S1500/S1500-SR/S1500M MAINTENANCE MANUAL		
						DRAW. No.	P1PA03586-B00X/6	CUST.	
02	Jan. 23, 2009	K.Okada	T.Anzai	IFujioka	Refer to Revision Record on page 2.				
Rev	DATE	DESIG.	CHECK	APPR.	DESCRIPTION		PFU LIMITED		
DESIG	Jan. 9, 2009	K.Okada	CHECK	T.Anzai	APPR.	IFujioka	PAGE	70/140	

- When installing the reflector, bump it in the direction of the arrow, and tighten the tapping screw.

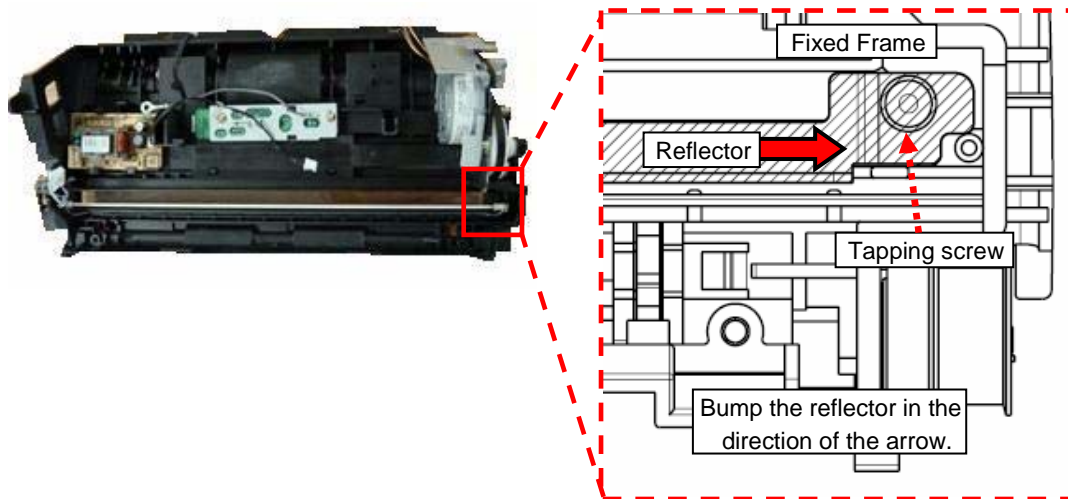

- When installing the reflector, the reflector should not step upon the rubber on the lamp socket.

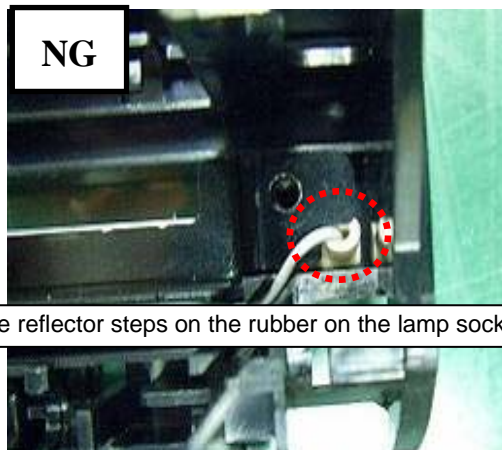
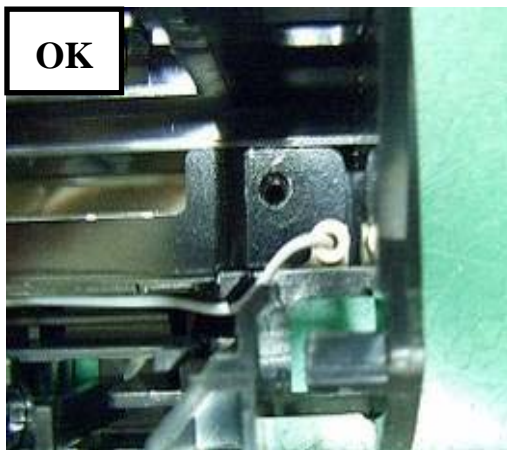

The reflector steps on the rubber on the lamp socket.

- After replacement, perform the image adjustment. (Refer to Section 6.6.)

						TITLE	ScanSnap S1500/S1500-SR/S1500M MAINTENANCE MANUAL		
						DRAW. No.	P1PA03586-B00X/6	CUST.	
02	Jan. 23, 2009	K.Okada	T.Anzai	IFujioka	Refer to Revision Record on page 2.				
Rev	DATE	DESIG.	CHECK	APPR.	DESCRIPTION		PFU LIMITED	PAGE	71/140
DESIG	Jan. 9, 2009	K.Okada	CHECK	T.Anzai	APPR.	IFujioka			

5.10.5 Inverter (for front side scanning)

NOTICE

Refer to Section 3.2.3 for the part number of Inverter.

<Removal>

- (1) Remove the following parts.
 - PCA Unit: Steps (1) ~ (3) in Section 5.7
 - Guide P ASSY: Section 5.6.2
 - LIDCOV ASSY: Section 5.6.1
 - Chute ASSY: Section 5.6.4
 - Base Cover ASSY: Step (2) in Section 5.9
 - Optical Unit: Steps (2) ~ (5) in Section 5.10.2
- (2) Disconnect the two connectors that are connected to the Inverter.

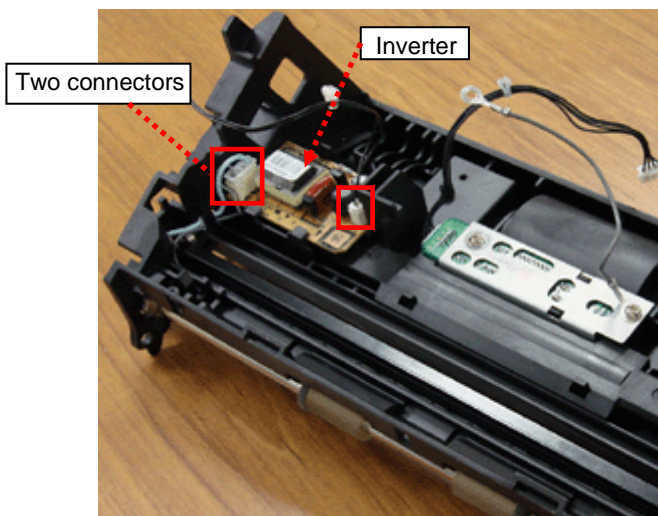

- (3) Unlatch the hook (square in the photo below), lift up the Inverter, and then remove it from the other two hooks (circles in the photo below).

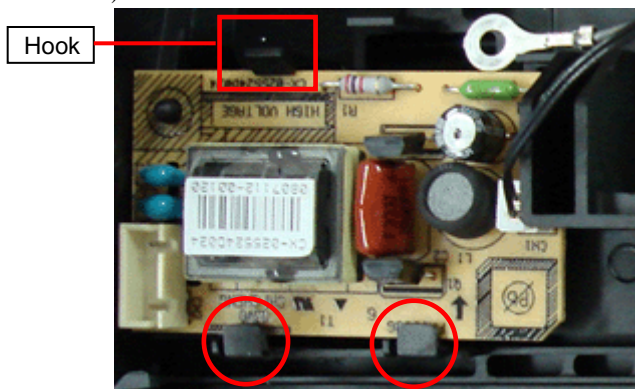

<Installation>

Follow the above procedure in reverse order.

NOTICE

- When installing the shield plate, if wrong cables or clamps are allocated, radio wave specifications may not be satisfied. By referring to Section 5.14.1, be sure to allocate the cables and clamps properly.
- When installing the PCB-UNIT, if a wrong cable is connected, radio wave specification may not be satisfied. By referring to Section 5.14.2, be sure to connect the cables properly.
- Refer to Section 5.13.3 for the cable installation order and clamp positions after installing the shield plate.
- After replacement, perform the image adjustment. (Refer to Section 6.6.)

						TITLE	ScanSnap S1500/S1500-SR/S1500M MAINTENANCE MANUAL		
						DRAW. No.	P1PA03586-B00X/6	CUST.	
02	Jan. 23, 2009	K.Okada	T.Anzai	I.Fujioka	Refer to Revision Record on page 2.				
Rev	DATE	DESIG.	CHECK	APPR.	DESCRIPTION		PFU LIMITED		
DESIG	Jan. 9, 2009	K.Okada	CHECK	T.Anzai	APPR.	I.Fujioka	PAGE	72/140	

5.10.6 Pick Shaft ASSY

NOTICE

Refer to Section 3.2.12 for the part number of Pick Shaft ASSY.

<Removal>

- (1) Open the ADF Top Section. (Refer to Section 7.1.2.)
- (2) Remove the Guide P ASSY. (Refer to Section 5.6.2.)
- (3) Rotate the bushing (left side) of the Pick Shaft ASSY.

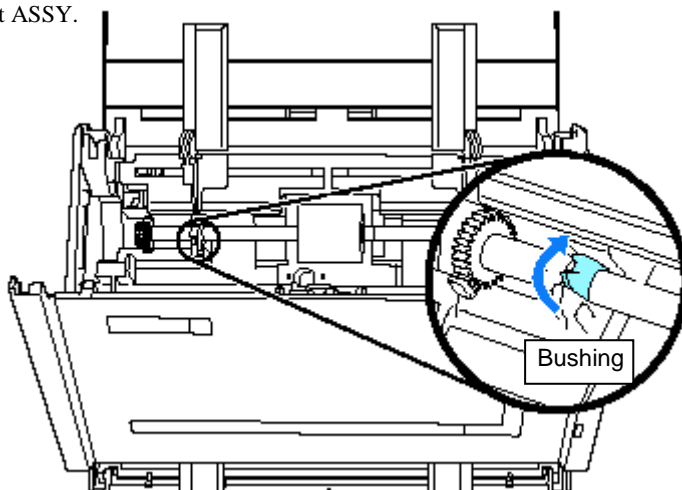

- (4) Slightly pill up the left part of the Pick Shaft ASSY (about 5 mm), move it towards the left side [1], and then raise it to remove [2].

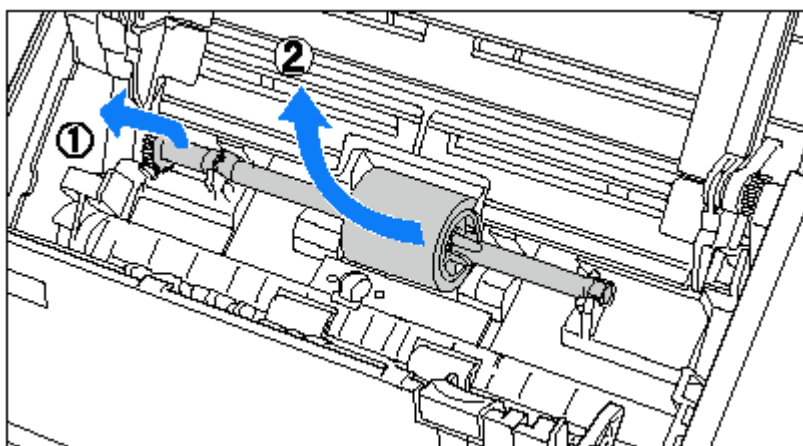

- (5) Pull out the shaft from the Pick Shaft ASSY while lifting up the Pickup tab to remove the Pick Roller.

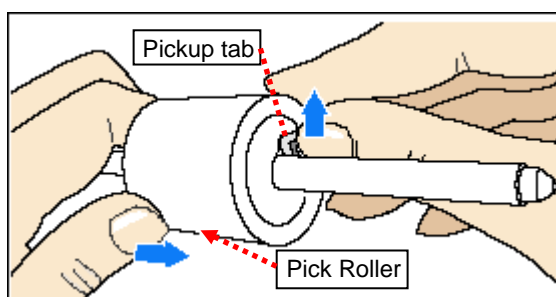

<Installation>

Follow the above procedure in reverse order.

NOTICE

Note the following points.

- The maintenance part Pick Shaft ASSY does not include the Pick roller. Be sure to install the same Pick roller onto the new Pick Shaft ASSY when replacing the Pick Shaft ASSY.
- Check that the Pick Shaft ASSY is securely installed. Otherwise, feeding error such as paper jam may occur.

						TITLE	ScanSnap S1500/S1500-SR/S1500M MAINTENANCE MANUAL		
						DRAW. No.	P1PA03586-B00X/6	CUST.	
02	Jan. 23, 2009	K.Okada	T.Anzai	IFujioka	Refer to Revision Record on page 2.				
Rev	DATE	DESIG.	CHECK	APPR.	DESCRIPTION				
DESIG	Jan. 9, 2009	K.Okada	CHECK	T.Anzai	APPR.	IFujioka	PFU LIMITED		PAGE 73/140

5.10.7 US Sensor F

NOTICE

Refer to Section 3.2.13 for the part number of US Sensor F.

<Removal>

- (1) Remove the following parts.
 - PCA Unit: Steps (1) ~ (3) in Section 5.7
 - Guide P ASSY: Section 5.6.2
 - LIDCOV ASSY: Section 5.6.1
 - Chute ASSY: Section 5.6.4
 - Base Cover ASSY: Step (2) in Section 5.9
 - Optical Unit: Steps (2) ~ (5) in Section 5.10.2
- (2) Remove the two tapping screws, and then US shield cover and FG cable.

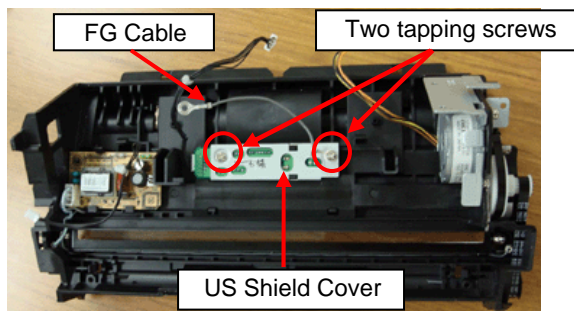

- (3) Remove the US Sensor F, and then disconnect the cable.

Disconnect the cable

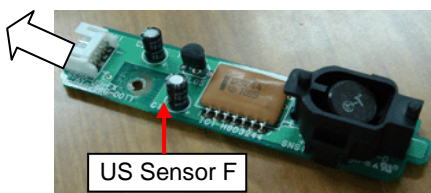

<Installation>

Follow the above procedure in reverse order.

- Refer to Section 5.13.3 for the cable installation order and clamp positions.

NOTICE

- When installing the shield plate, if wrong cables or clamps are allocated, radio wave specifications may not be satisfied. By referring to Section 5.14.1, be sure to allocate the cables and clamps properly.
- When installing the PCB-UNIT, if a wrong cable is connected, radio wave specification may not be satisfied. By referring to Section 5.14.2, be sure to connect the cables properly.
- When installing the FG cable, route it properly.

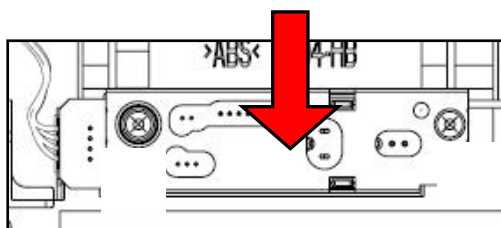

- When installing the US shield cover, move it to the direction of the arrow, and tighten the tapping screws in the order of the number above.
- The cable terminal shall touch the sheet metal surface.

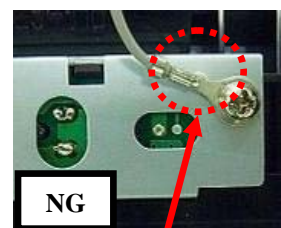
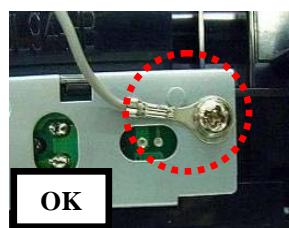

- FG cable shall not come on the dowel.

						TITLE	ScanSnap S1500/S1500-SR/S1500M MAINTENANCE MANUAL		
						DRAW. No.	P1PA03586-B00X/6		CUST.
02	Jan. 23, 2009	K.Okada	T.Anzai	IFujioka	Refer to Revision Record on page 2.				
Rev	DATE	DESIG.	CHECK	APPR.	DESCRIPTION	PFU LIMITED		PAGE	74/140
DESIG	Jan. 9, 2009	K.Okada	CHECK	T.Anzai	APPR. IFujioka				

5.10.8 Feed Roller

NOTICE

Refer to Section 3.2.14 for the part number of Feed Roller.

<Removal>

- (1) Remove the following parts.
 - PCA Unit: Steps (1) ~ (3) in Section 5.7
 - Guide P ASSY: Section 5.6.2
 - LIDCOV ASSY: Section 5.6.1
 - Chute ASSY: Section 5.6.4
 - Base Cover ASSY: Step (2) in Section 5.9
 - Optical Unit: Steps (2) ~ (5) in Section 5.10.2
 - Inverter (for front side scanning): Steps (2) ~ (3) in Section 5.10.5
 - US Sensor F: Steps (2) ~ (3) in Section 5.10.7

- (2) Unlatch the two claws in the center, unlatch the claw at the right side to lift the roller plate, and then remove the roller plate from the left side frame.

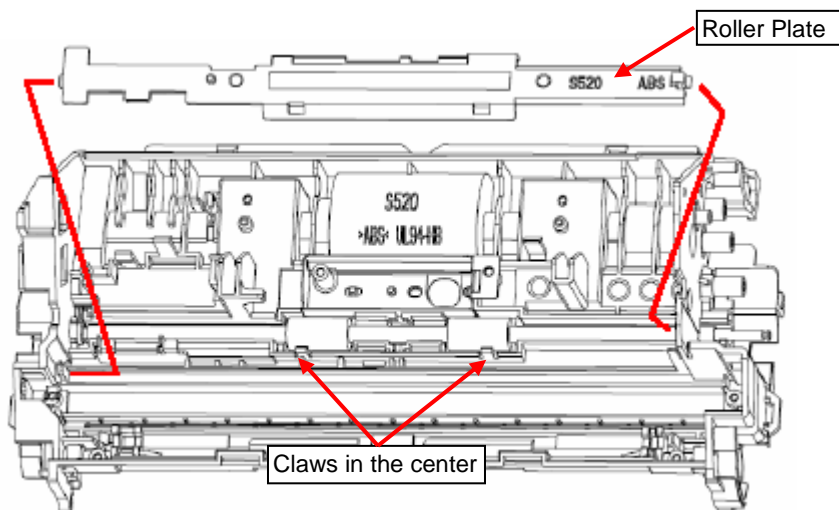

- (3) Loosen the adjusting screw to remove the belt.

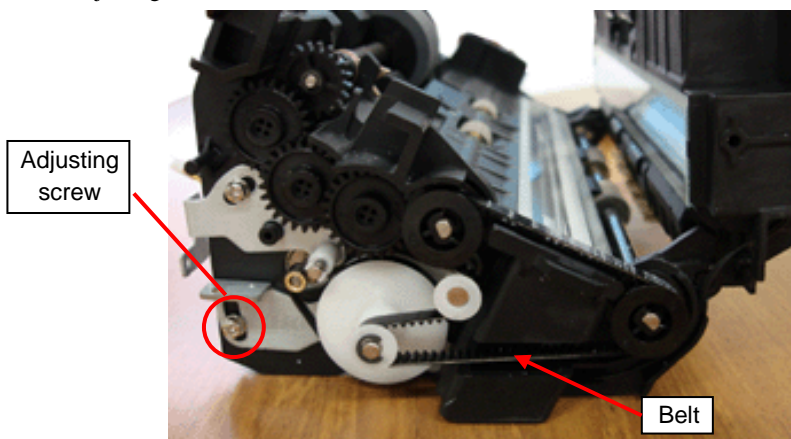

						TITLE	ScanSnap S1500/S1500-SR/S1500M MAINTENANCE MANUAL			
						DRAW. No.	P1PA03586-B00X/6	CUST.		
02	Jan. 23, 2009	K.Okada	T.Anzai	IFujioka	Refer to Revision Record on page 2.					
Rev	DATE	DESIG.	CHECK	APPR.	DESCRIPTION		PFU LIMITED		PAGE	75/140
DESIG	Jan. 9, 2009	K.Okada	CHECK	T.Anzai		APPR.	IFujioka			

(4) Unlatch the claw with a flat-blade screwdriver, and then pull the pulley out of the Feed Roller shaft.

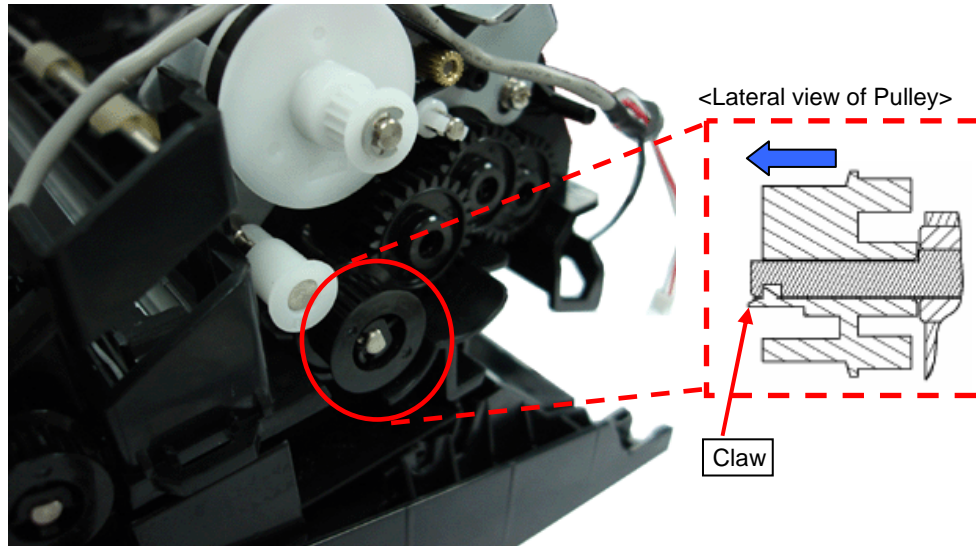

NOTICE

If you use a screwdriver when pulling the pulley from the Feed Roller, be careful not to damage the other p

<Good example>

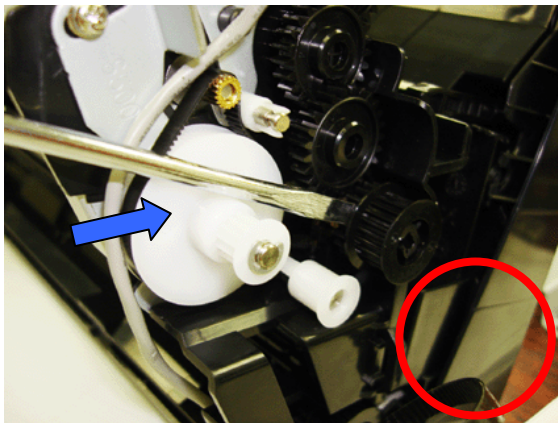

* Let the driver touch the center of the pulley in the front.

<Bad Example>

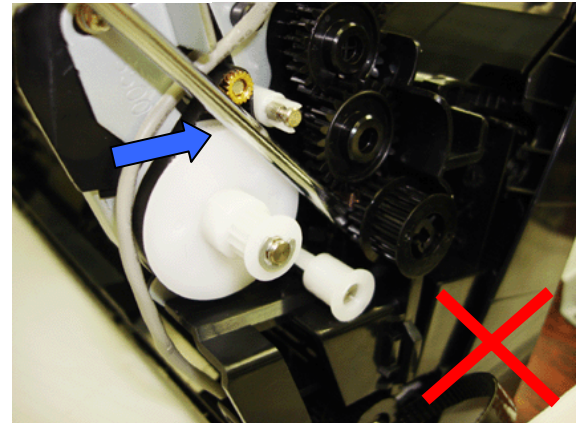

* Do NOT let the driver touch the edge of the pulley in the front.

(5) Lift up the left bushing with a flat-blade screwdriver, and pull it out of the Feed Roller shaft to remove.

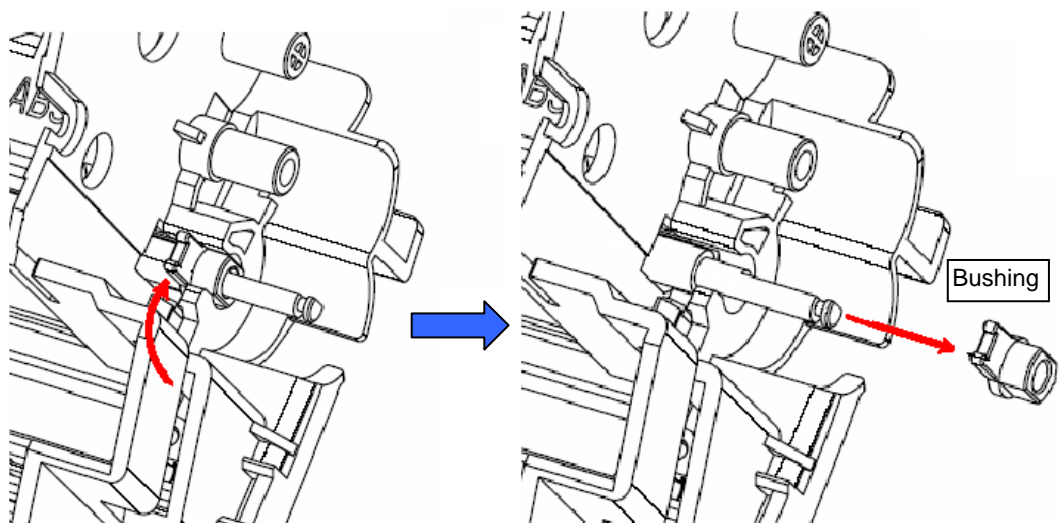

						TITLE	ScanSnap S1500/S1500-SR/S1500M MAINTENANCE MANUAL			
						DRAW. No.	P1PA03586-B00X/6	CUST.		
02	Jan. 23, 2009	K.Okada	T.Anzai	IFujioka	Refer to Revision Record on page 2.					
Rev	DATE	DESIG.	CHECK	APPR.	DESCRIPTION					
DESIG	Jan. 9, 2009	K.Okada	CHECK	T.Anzai		APPR.	IFujioka	PFU LIMITED	PAGE	76/140

- (6) Remove the Feed Roller.
 - a) Lift up the right bushing with a flat-blade screwdriver.
 - b) Remove the Feed Roller.
 - c) Remove the right bushing from the Feed Roller.

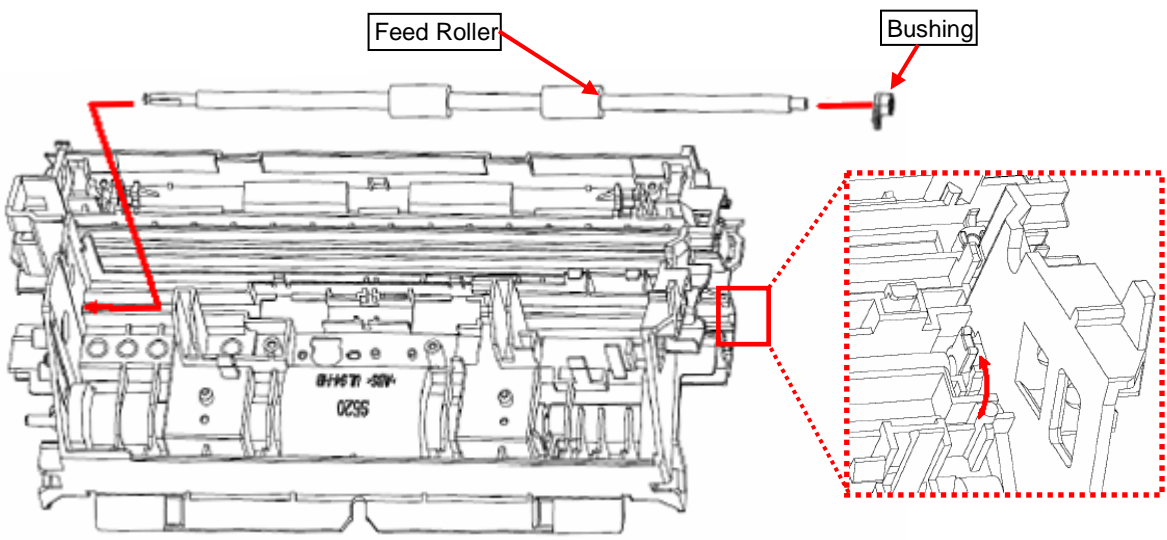

						TITLE	ScanSnap S1500/S1500-SR/S1500M MAINTENANCE MANUAL		
						DRAW. No.	P1PA03586-B00X/6	CUST.	
02	Jan. 23, 2009	K.Okada	T.Anzai	IFujioka	Refer to Revision Record on page 2.				
Rev	DATE	DESIG.	CHECK	APPR.	DESCRIPTION	PFU LIMITED		PAGE	77/140
DESIG	Jan. 9, 2009	K.Okada	CHECK	T.Anzai	APPR.	IFujioka			

<Installation>

Follow the above procedure in reverse order.

NOTICE

Note the following points.

- Make sure that the claw on the pulley is securely latched to the Feed Roller groove.
- When installing the shield plate, if wrong cables or clamps are allocated, radio wave specifications may not be satisfied. By referring to Section 5.14.1, be sure to allocate the cables and clamps properly.
- When installing the PCB-UNIT, if a wrong cable is connected, radio wave specification may not be satisfied. By referring to Section 5.14.2, be sure to connect the cables properly.

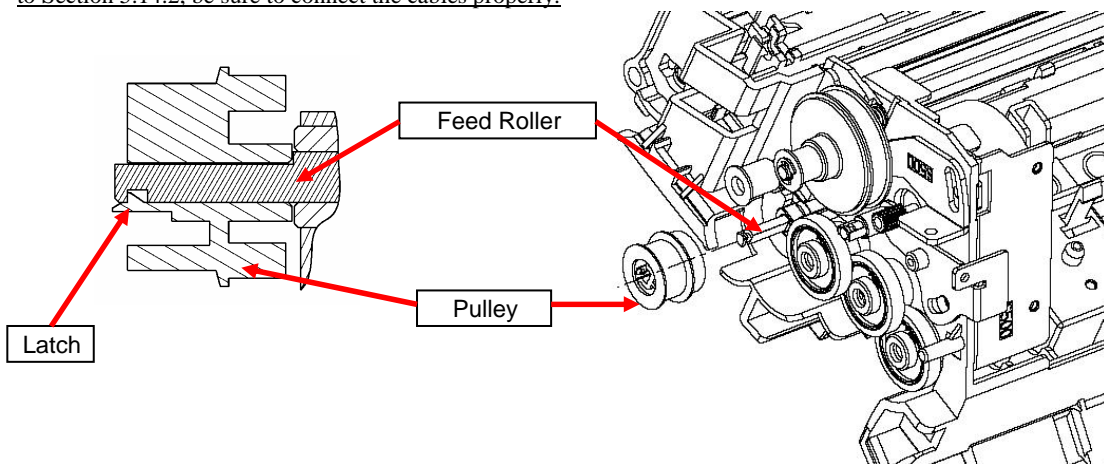

- After pushing in the pulley, check that the pulley does not come off when pulled, and that the Feed roller has a thrust (gap).

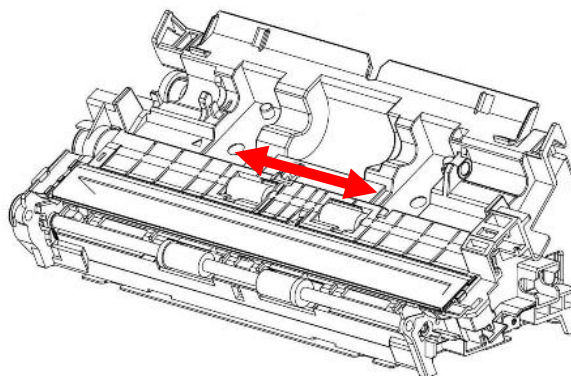
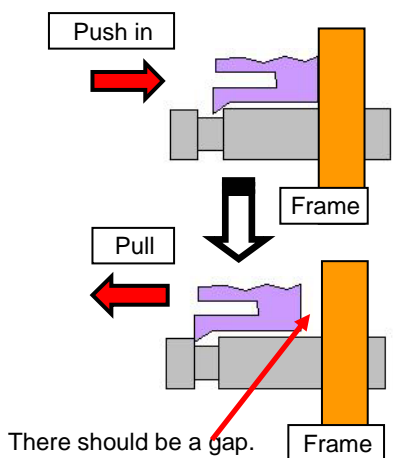

Check that the Feed roller moves to the right and left.

- Tension adjustment is required with a spring gauge when installing the Belt (tightening the adjusting crew). (Refer to Section 5.13.)
- Set the belt external side of the pulley. Rotate the gear two or three times after installing the Belt. (Refer to the figure on the right.)
- After replacement, perform the image adjustment. (Refer to Section 6.6.)

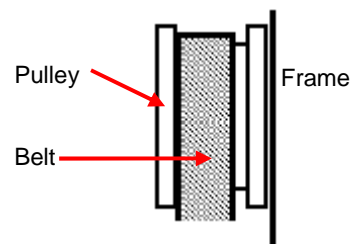

						TITLE	ScanSnap S1500/S1500-SR/S1500M MAINTENANCE MANUAL		
						DRAW. No.	P1PA03586-B00X/6	CUST.	
02	Jan. 23, 2009	K.Okada	T.Anzai	IFujioka	Refer to Revision Record on page 2.				
Rev	DATE	DESIG.	CHECK	APPR.	DESCRIPTION				
DESIG	Jan. 9, 2009	K.Okada	CHECK	T.Anzai	APPR.	IFujioka	PFU LIMITED		PAGE 78/140

5.10.9 Fix Sub Unit

NOTICE

- Refer to Section 3.2.10 for the part number of Fix Sub Unit.
- The Fix Sub Unit is the parts that eliminate the shield cover, Optical Unit, Pick Shaft ASSY, Lamp, Inverter and US Sensor F from the Fixed Unit.

<Removal>

- (1) Remove the following parts.
 - PCA Unit: Steps (1) ~ (3) in Section 5.7
 - Guide P ASSY: Section 5.6.2
 - LIDCOV ASSY: Section 5.6.1
 - Chute ASSY: Section 5.6.4
 - Pick Shaft ASSY: Steps (3) ~ (4) in Section 5.10.6
 - Base Cover ASSY: Step (2) in Section 5.9

<<Fixed Unit>>

- Optical Unit: Steps (2) ~ (5) in Section 5.10.2
- Lamp: Steps (2) ~ (4) in Section 5.10.4
- Inverter: Steps (2) and (3) in Section 5.10.5
- US Sensor F: Steps (2) and (3) on Section 5.10.7

<<Revolve Unit>>

- Top Cover ASSY Unit: Steps (2) ~ (3) in Section 5.11.1
- Guide A: Step (2) in Section 5.8

- (2) Separate the Fixed unit and the Revolve Unit. (Refer to steps (2) ~ (7) in Section 5.12.)

<Installation of the Fixed Unit and the Revolve Unit>

Follow the above procedure in reverse order.

NOTICE

Note the following points.

- When installing the shield plate, if wrong cables or clamps are allocated, radio wave specifications may not be satisfied. By referring to Section 5.14.1, be sure to allocate the cables and clamps properly.
- When installing the PCB-UNIT, if a wrong cable is connected, radio wave specification may not be satisfied. By referring to Section 5.14.2, be sure to connect the cables properly.
- There are a few types of screws. Do not install the wrong type.
- Route the cables as shown in the photo below.



- After replacing the Fixed Unit, perform the image adjustment. (Refer to Section 6.6.)

						TITLE	ScanSnap S1500/S1500-SR/S1500M MAINTENANCE MANUAL			
						DRAW. No.	P1PA03586-B00X/6	CUST.		
02	Jan. 23, 2009	K.Okada	T.Anzai	IFujioka	Refer to Revision Record on page 2.					
Rev	DATE	DESIG.	CHECK	APPR.	DESCRIPTION				PAGE	79/140
DESIG	Jan. 9, 2009	K.Okada	CHECK	T.Anzai	APPR.	IFujioka	PFU LIMITED			

5.11 Replacing the Parts inside of Revolve Unit

5.11.1 Top Cover ASSY

NOTICE

Refer to Section 3.2.8 for the part number of Top Cover ASSY.

<Removal>

- (1) Remove the Stacker ASSY. (Refer to Section 5.6.3.)
- (2) Remove two fixing screws at the both sides of the Top Cover ASSY.

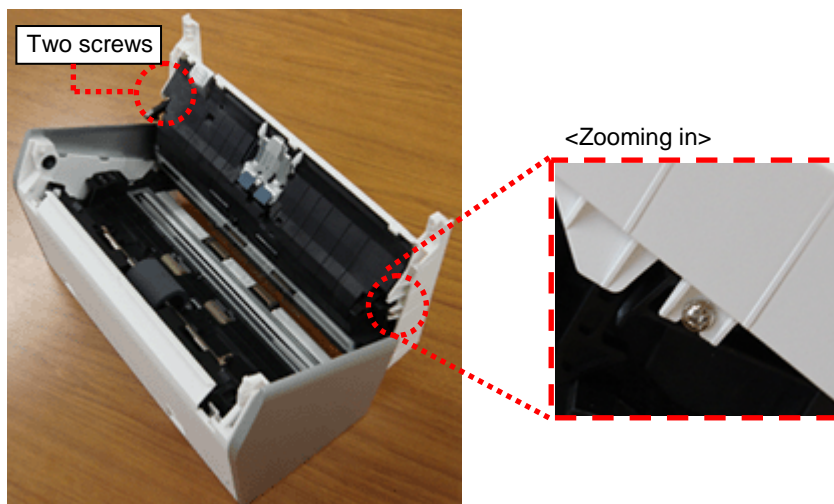

- (3) Unlatch the two claws as shown with arrows [1] at first, and then the two claws with arrows [2]. Finally remove the Top Cover ASSY by unlocking the four claws as shown with the arrows on the upper area.

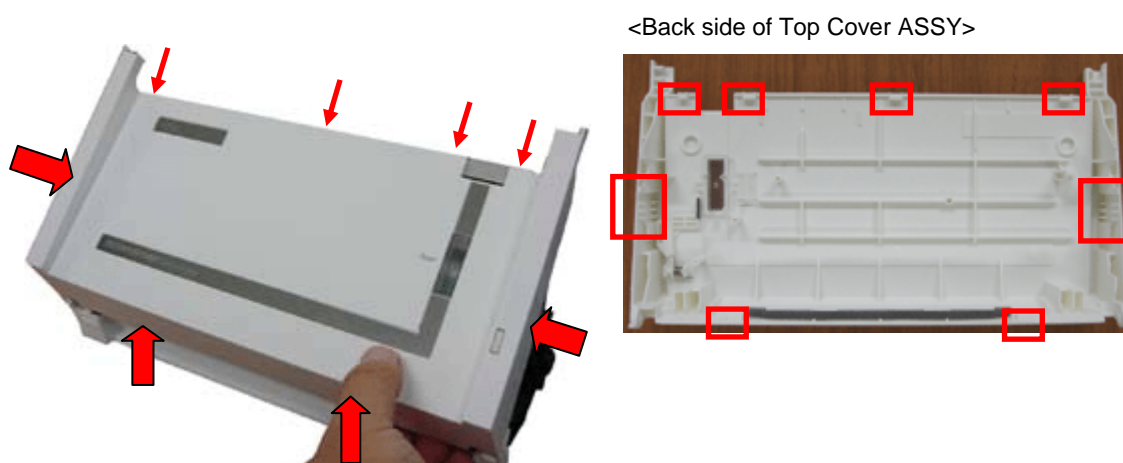

<Installation>

Follow the above procedure in reverse order.

- When installing the Top Cover ASSY and the Revolve Frame, tighten the tapping screw by pressing the top and bottom with a hand so that the Top Cover ASSY does not move up.

						TITLE	ScanSnap S1500/S1500-SR/S1500M MAINTENANCE MANUAL		
						DRAW. No.	P1PA03586-B00X/6	CUST.	
02	Jan. 23, 2009	K.Okada	T.Anzai	IFujioka	Refer to Revision Record on page 2.		PFU LIMITED	PAGE	80/140
Rev	DATE	DESIG.	CHECK	APPR.	DESCRIPTION				
DESIG	Jan. 9, 2009	K.Okada	CHECK	T.Anzai	APPR.	IFujioka			

5.11.2 Panel PCA

NOTICE

Refer to Section 3.2.5 for the part number of Panel PCA.

<Removal>

- (1) Save the Log data. (Refer to Section 6.3.)
- (2) Remove the following parts.
 - Stacker ASSY: Section 5.6.3
 - Top Cover ASSY: Section 5.11.1
- (3) Unlatch the two claws on the Panel PCA, and lift up the Panel PCA slightly.
- (4) Disconnect one connector on the Panel PCA and remove the Panel PCA from the two positioning pins.

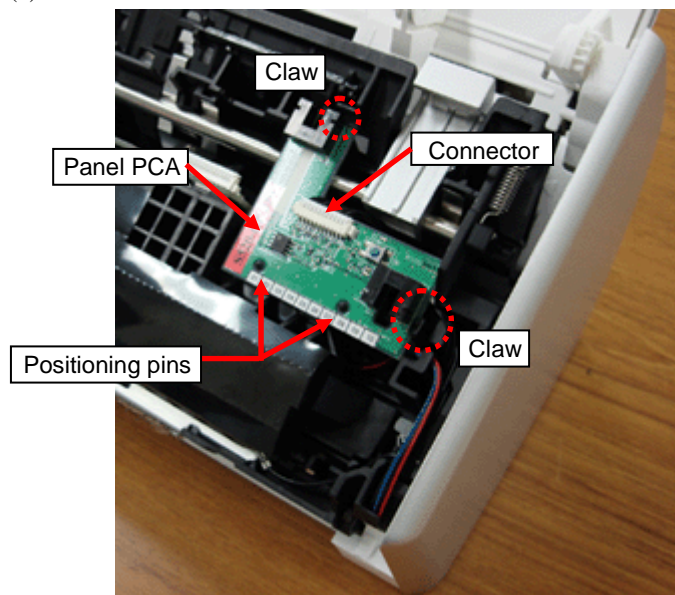

<Installation>

Follow the above procedure in reverse order.

NOTICE

Note the following points.

Insert the Panel PCA into the two positioning pins, and then follow the above procedure in reverse order.

- Restore the Log data. (Refer to Section 6.4.)
- Perform the image adjustment. (Refer to Section 6.6.)

						TITLE	ScanSnap S1500/S1500-SR/S1500M MAINTENANCE MANUAL		
						DRAW. No.	P1PA03586-B00X/6	CUST.	
02	Jan. 23, 2009	K.Okada	T.Anzai	IFujioka	Refer to Revision Record on page 2.				
Rev	DATE	DESIG.	CHECK	APPR.	DESCRIPTION		PFU LIMITED	PAGE	81/140
DESIG	Jan. 9, 2009	K.Okada	CHECK	T.Anzai		APPR. IFujioka			

5.11.3 Optical Unit (for backside scanning)

NOTICE

Refer to Section 3.2.4 for the part number of Optical Unit.

<Removal>

- (1) Remove the following parts.
 - Stacker ASSY: Section 5.6.3
 - Top Cover ASSY: Steps (2) ~ (3) in Section 5.11.1
 - Panel PCA: Steps (3) ~ (4) in Section 5.11.2
- (2) Disconnect one connector from the Optical Unit.
- (3) Unlatch two claws on the Revolve Unit, and then remove the Optical Unit.

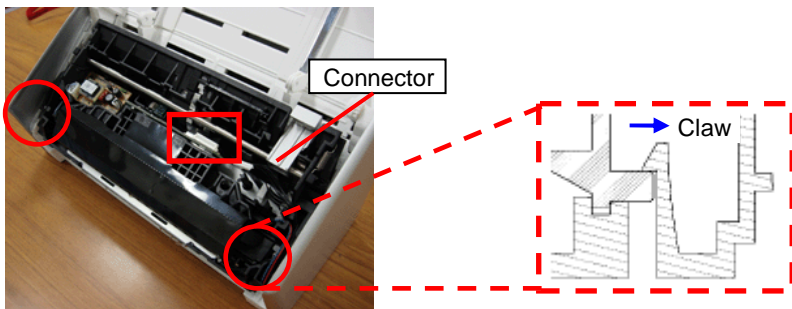

<Installation>

Follow the above procedure in reverse order.

NOTICE

Note the following points.

- Check that the Optical Unit is securely latched with the two claws on the Revolve Unit.
- Route the cables as shown in the photo below.

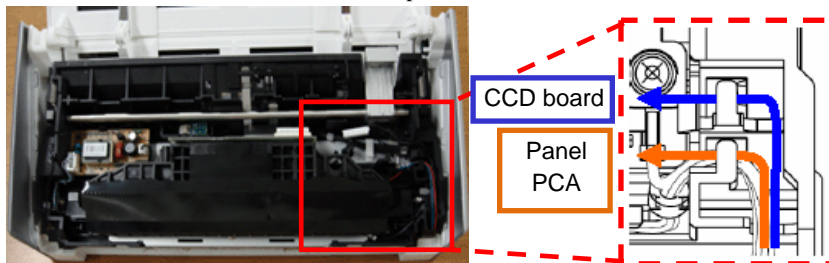

- The cable connected to the CCD board shall go through the upper hook, and the cable connected to the Panel PCA shall go through the lower hook.

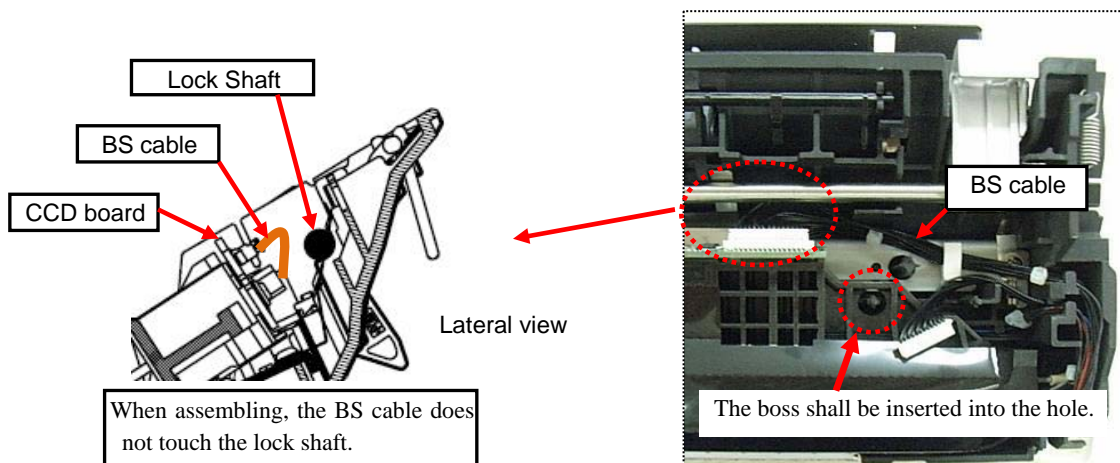

- After replacement, perform the image adjustment. (Refer to Section 6.6.)

						TITLE	ScanSnap S1500/S1500-SR/S1500M MAINTENANCE MANUAL		
						DRAW. No.	P1PA03586-B00X/6	CUST.	
02	Jan. 23, 2009	K.Okada	T.Anzai	IFujioka	Refer to Revision Record on page 2.				
Rev	DATE	DESIG.	CHECK	APPR.	DESCRIPTION		PFU LIMITED	PAGE	82/140
DESIG	Jan. 9, 2009	K.Okada	CHECK	T.Anzai	APPR.	IFujioka			

5.11.4 Lamp (for backside scanning)

NOTICE

Refer to Section 3.2.2 for the part number of Lamp.

<Removal>

- (1) Remove the following parts.
 - Stacker ASSY: Section 5.6.3
 - Top Cover ASSY: Steps (2) ~ (3) in Section 5.11.1
 - Panel PCA: Steps (3) ~ (4) in Section 5.11.2
 - Optical Unit: Steps (2) ~ (3) in Section 5.11.3
- (2) Disconnect the Lamp connector from the Inverter.
- (3) Remove two tapping screws that secure the reflector, and then remove the reflector.

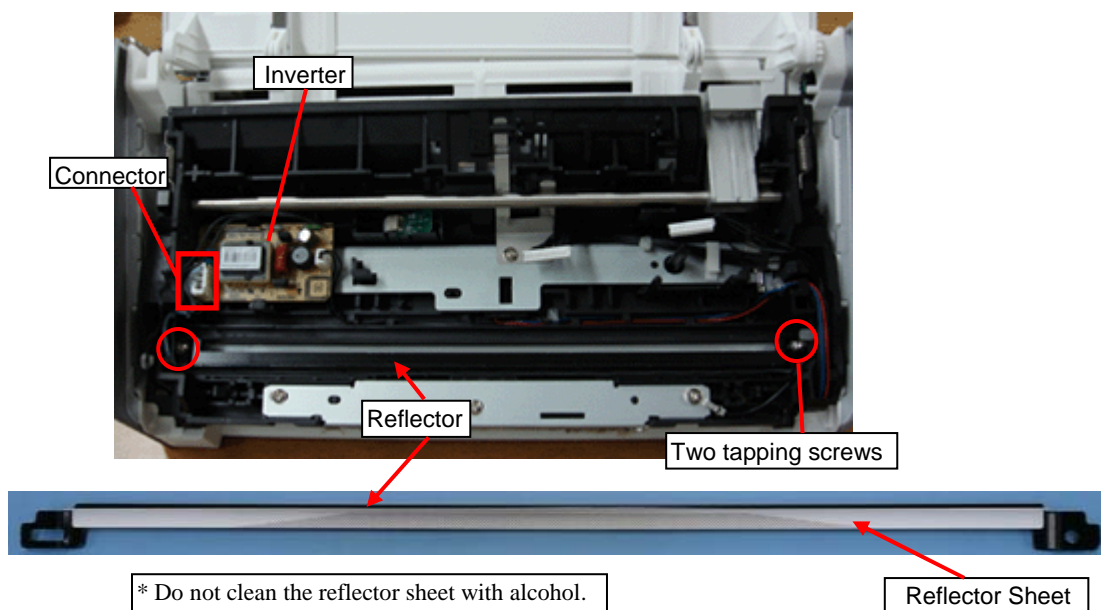

- (4) Take the Lamp out of the frame groove on the Revolve Unit and remove.

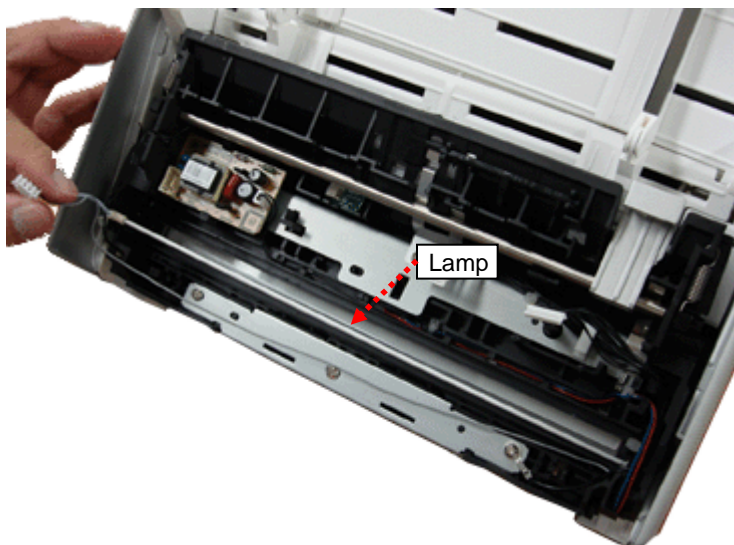

						TITLE	ScanSnap S1500/S1500-SR/S1500M MAINTENANCE MANUAL		
						DRAW. No.	P1PA03586-B00X/6	CUST.	
02	Jan. 23, 2009	K.Okada	T.Anzai	IFujioka	Refer to Revision Record on page 2.				
Rev	DATE	DESIG.	CHECK	APPR.	DESCRIPTION	PFU LIMITED		PAGE	83/140
DESIG	Jan. 9, 2009	K.Okada	CHECK	T.Anzai	APPR. IFujioka				

<Installation>

Follow the above procedure in reverse order.

NOTICE

Note the following points.

- Insert the reflector sheet between the Lamp and the frame.
- Bump the edge of the Lamp into the Revolve frame.

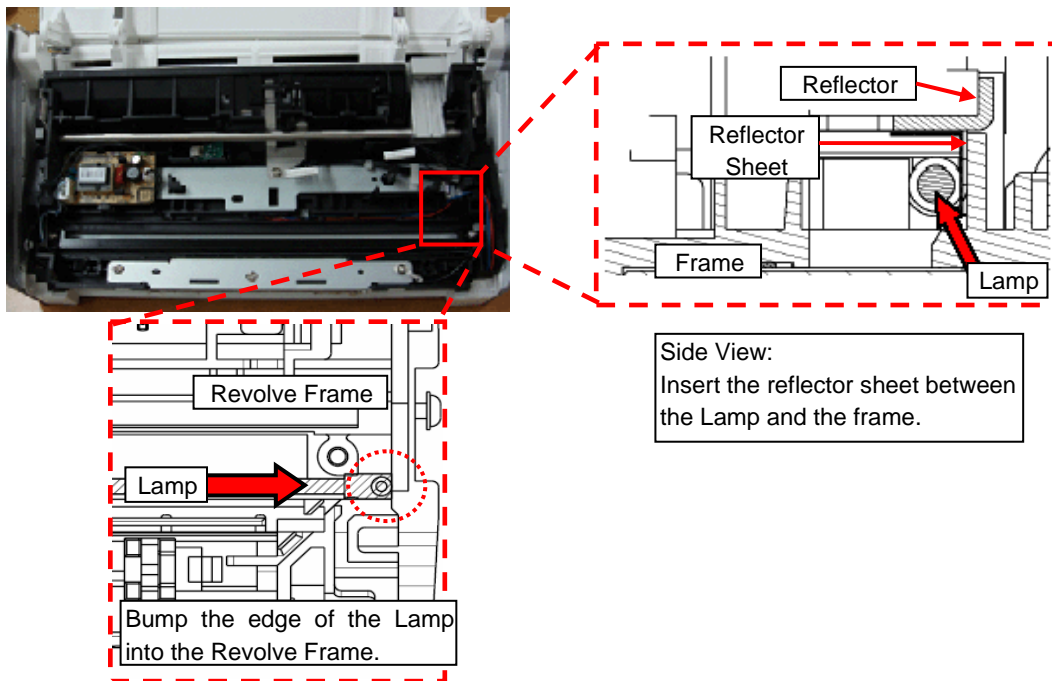

- Route the Lamp cable as shown in the photo below.

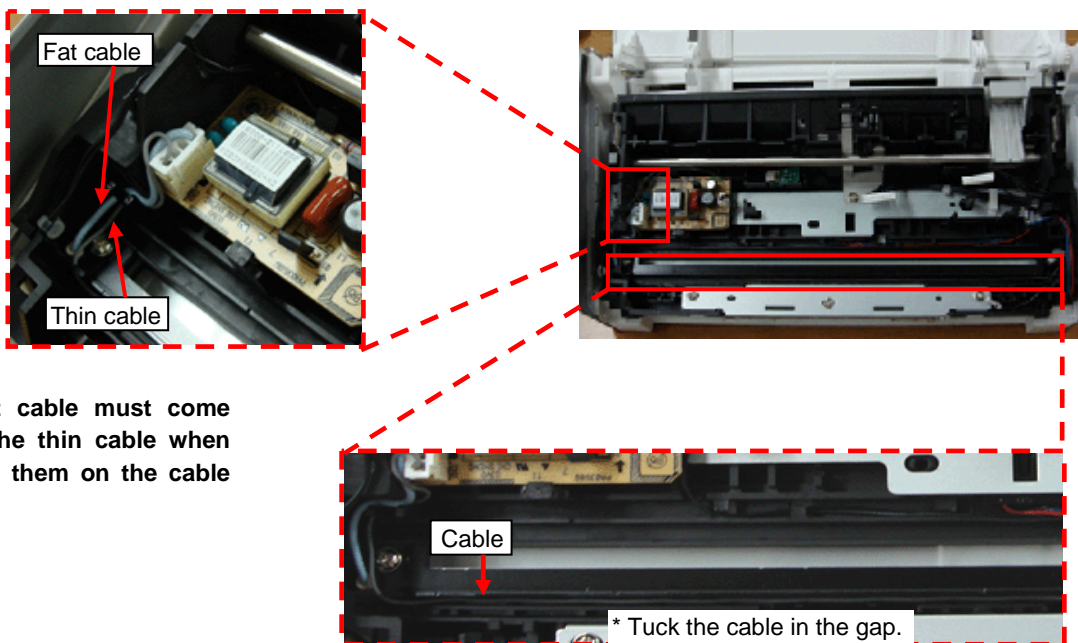

* The fat cable must come above the thin cable when hooking them on the cable hook.

						TITLE	ScanSnap S1500/S1500-SR/S1500M MAINTENANCE MANUAL		
						DRAW. No.	P1PA03586-B00X/6	CUST.	
02	Jan. 23, 2009	K.Okada	T.Anzai	IFujioka	Refer to Revision Record on page 2.				
Rev	DATE	DESIG.	CHECK	APPR.	DESCRIPTION		PFU LIMITED		
DESIG	Jan. 9, 2009	K.Okada	CHECK	T.Anzai	APPR.	IFujioka	PAGE	84/140	

When installing the reflector, bump it in the direction of the arrow, and tighten the tapping screw.

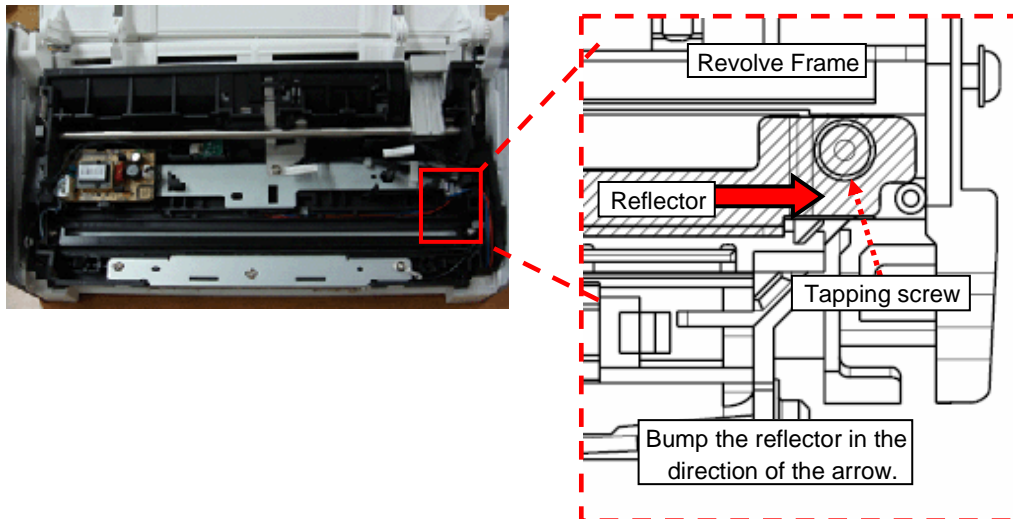

- When installing the reflector, the reflector should not step upon the rubber on the lamp socket.

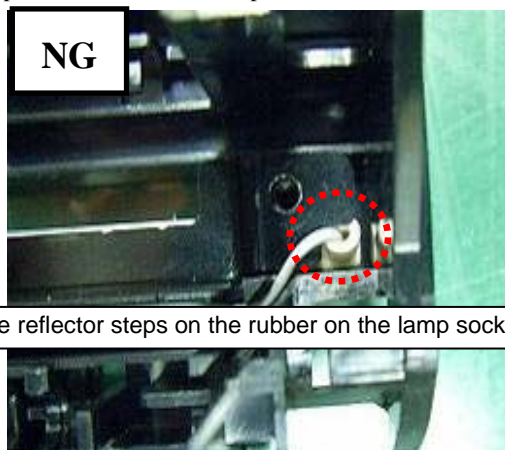
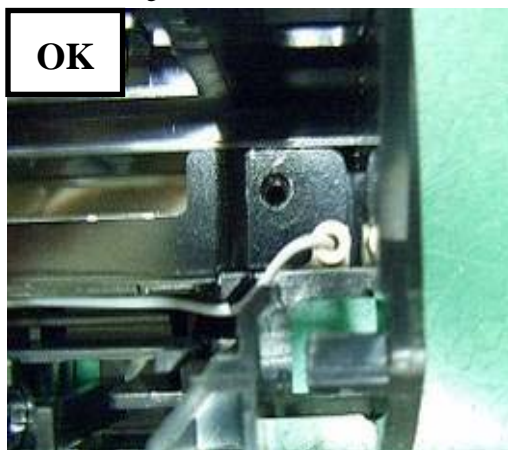

- After replacement, perform the image adjustment. (Refer to Section 6.6)

						TITLE	ScanSnap S1500/S1500-SR/S1500M MAINTENANCE MANUAL			
						DRAW. No.	P1PA03586-B00X/6	CUST.		
02	Jan. 23, 2009	K.Okada	T.Anzai	IFujioka	Refer to Revision Record on page 2.		PFU LIMITED		PAGE	85/140
Rev	DATE	DESIG.	CHECK	APPR.	DESCRIPTION					
DESIG	Jan. 9, 2009	K.Okada	CHECK	T.Anzai		APPR.	IFujioka			

5.11.5 Inverter (for backside scanning)

NOTICE

Refer to Section 3.2.3 for the part number of Inverter.

<Removal>

- (1) Remove the following parts.
 - Stacker ASSY: Section 5.6.3
 - Top Cover ASSY: Steps (2) ~ (3) in Section 5.11.1
 - Panel PCA: Steps (3) ~ (4) in Section 5.11.2
 - Optical Unit: Steps (2) ~ (3) in Section 5.11.3

- (2) Disconnect two connectors from the Inverter.

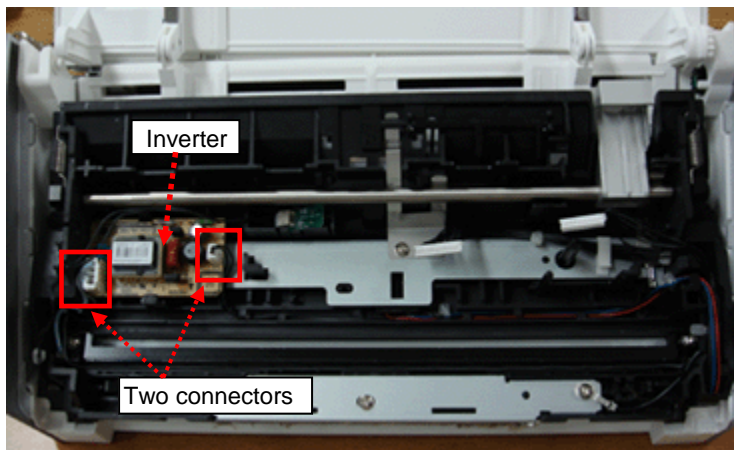

- (3) Unlatch two claws to remove the Inverter.

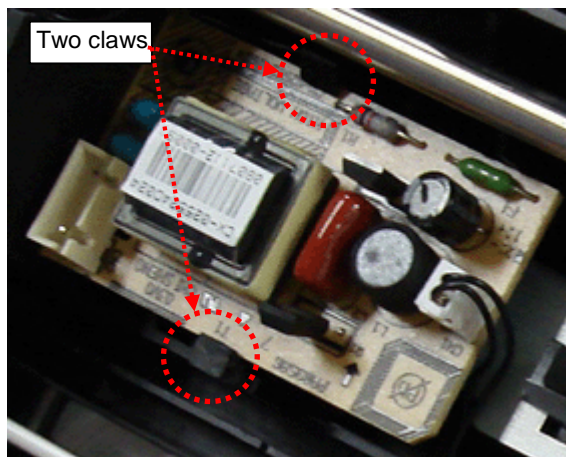

<Installation>

Follow the above procedure in reverse order.

NOTICE

After replacement, perform the image adjustment. (Refer to Section 6.6.)

						TITLE	ScanSnap S1500/S1500-SR/S1500M MAINTENANCE MANUAL			
						DRAW. No.	P1PA03586-B00X/6	CUST.		
02	Jan. 23, 2009	K.Okada	T.Anzai	IFujioka	Refer to Revision Record on page 2.					
Rev	DATE	DESIG.	CHECK	APPR.	DESCRIPTION			PFU LIMITED	PAGE	86/140
DESIG	Jan. 9, 2009	K.Okada	CHECK	T.Anzai	APPR.	IFujioka				

5.11.6 Sensor ASSY B3

NOTICE

Refer to Section 3.2.7 for the part number of Sensor ASSY B3.

*** When removing the Sensor ASSY B3, the Feed FG Plate may be distorted if pulled out. If the Feed FG Plate is distorted, the defect that may be the cause of floaty grounding wire which results in communication error or malfunction. To avoid distortion, be sure to follow the procedure below when removing the Feed FG Plate.**

<Removal>

- (1) Remove the following parts.
 - PCA Unit: Steps (1) ~ (3) in Section 5.7
 - Guide P ASSY: Section 5.6.2
 - LIDCOV ASSY: Section 5.6.1
 - Chute ASSY: Section 5.6.4
 - Base Cover ASSY: Step (2) in Section 5.9
 - Stacker ASSY: Section 5.6.3
 - Top Cover ASSY: Steps (2) ~ (3) in Section 5.11.1
 - Panel PCA: Steps (3) ~ (4) in Section 5.11.2
 - Optical Unit: Steps (2) ~ (3) in Section 5.11.3
 - Inverter: Steps (2) ~ (3) in Section 5.11.5

- (2) Remove the lock springs at the both sides of the Revolve Unit.

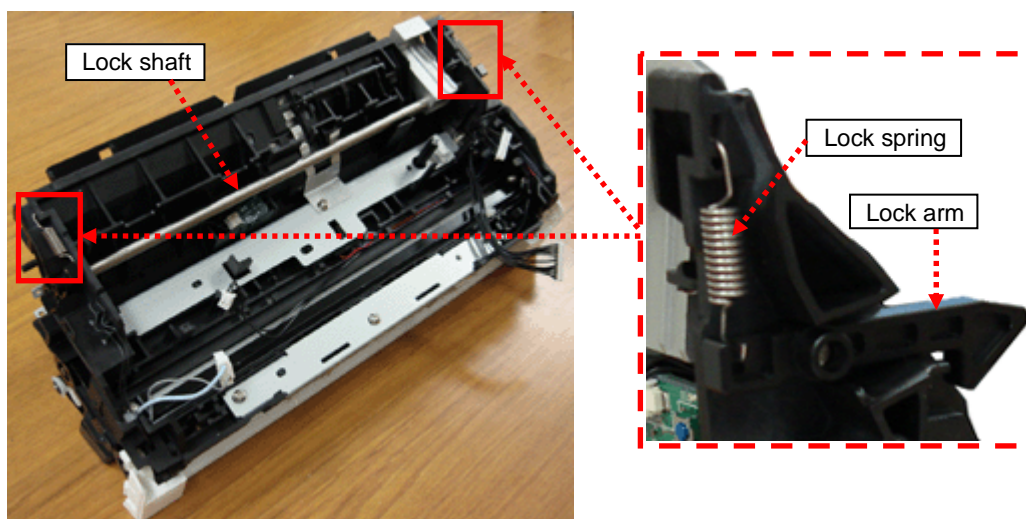

- (3) Remove the two lock arms from the lock shaft.

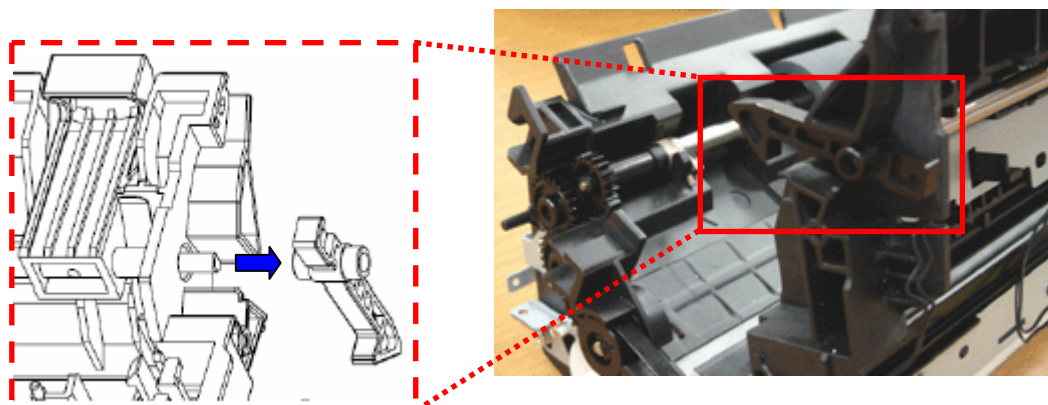

						TITLE	ScanSnap S1500/S1500-SR/S1500M MAINTENANCE MANUAL		
						DRAW. No.	P1PA03586-B00X/6	CUST.	
02	Jan. 23, 2009	K.Okada	T.Anzai	IFujioka	Refer to Revision Record on page 2.				
Rev	DATE	DESIG.	CHECK	APPR.	DESCRIPTION				
DESIG	Jan. 9, 2009	K.Okada	CHECK	T.Anzai	APPR.	IFujioka	PFU LIMITED		PAGE 87/140

- (4) Remove the lock shaft from the frame.
- Slide the lock shaft to the left to remove from the frame at the right side, and then pull it out of the Revolve frame.

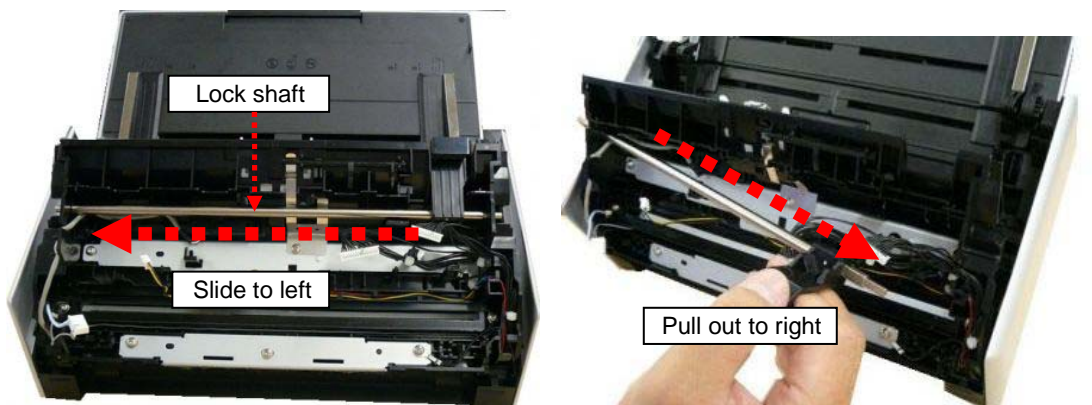

- (5) Remove the feed FG plate, and then the feed plate.
- * The tapping screw at the right side (tightened with the FG cable) that secures the feed plate has a washer.

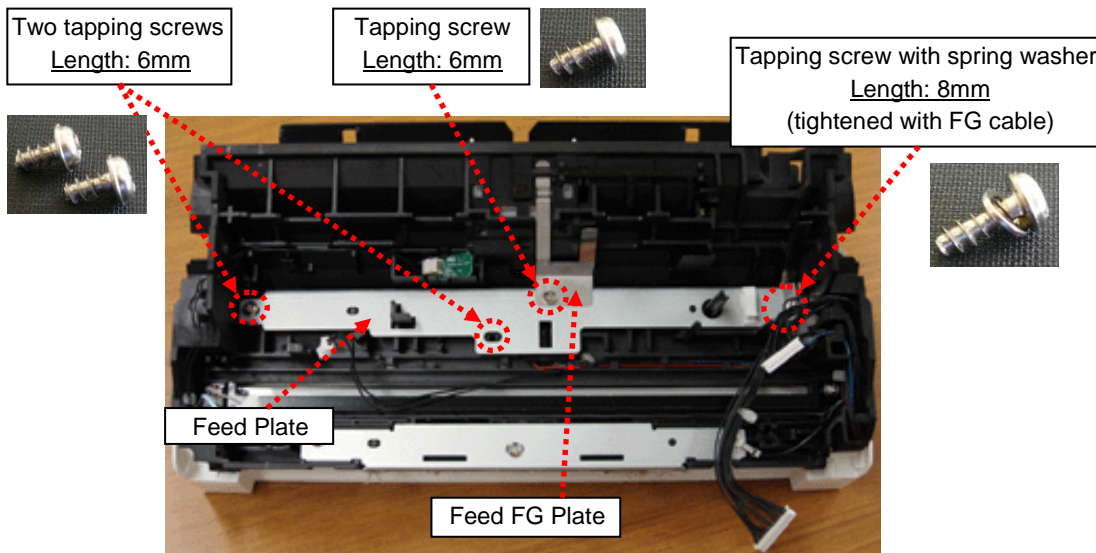

						TITLE	ScanSnap S1500/S1500-SR/S1500M MAINTENANCE MANUAL		
						DRAW. No.	P1PA03586-B00X/6	CUST.	
02	Jan. 23, 2009	K.Okada	T.Anzai	IFujioka	Refer to Revision Record on page 2.				
Rev	DATE	DESIG.	CHECK	APPR.	DESCRIPTION				
DESIG	Jan. 9, 2009	K.Okada	CHECK	T.Anzai	APPR.	IFujioka	PFU LIMITED		PAGE 88/140

(6) Unlatch the two claws with a flat-blade screwdriver to remove the sensor section from the frame.

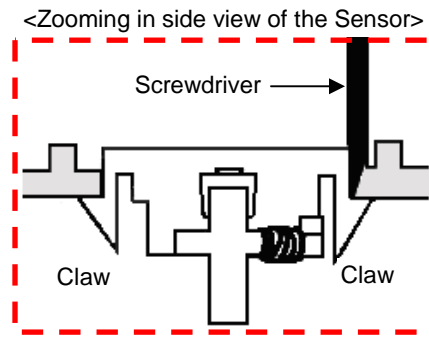
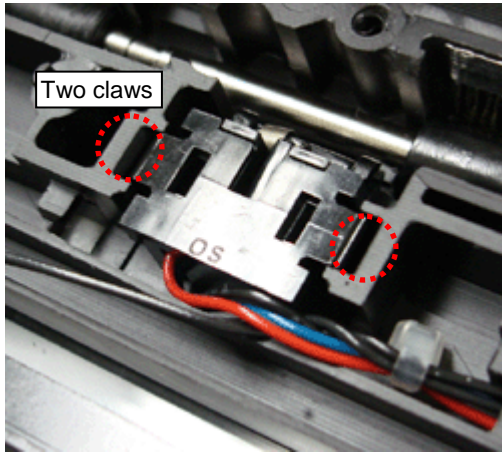

(7) Detach the cables on the Sensor ASSY B3 from the forming to completely remove from the Revolve Unit.

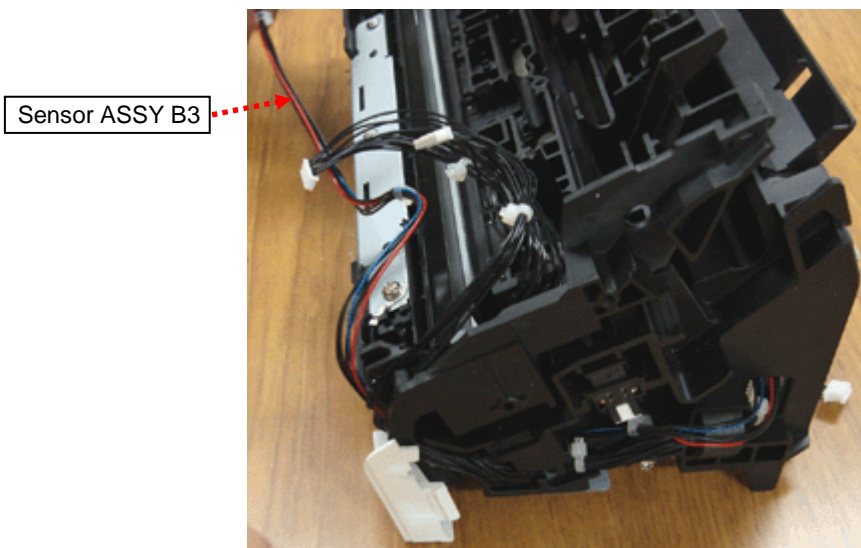

						TITLE	ScanSnap S1500/S1500-SR/S1500M MAINTENANCE MANUAL			
						DRAW. No.	P1PA03586-B00X/6	CUST.		
02	Jan. 23, 2009	K.Okada	T.Anzai	IFujioka	Refer to Revision Record on page 2.		PFU LIMITED		PAGE	89/140
Rev	DATE	DESIG.	CHECK	APPR.	DESCRIPTION		PFU LIMITED		PAGE	89/140
DESIG	Jan. 9, 2009	K.Okada	CHECK	T.Anzai		APPR.	IFujioka			

<Installation>

Follow the above procedure in reverse order

NOTICE

- If the Feed FG Plate is distorted, the defect that may be the cause of floaty grounding wire which results in communication error or malfunction. To avoid distortion, be sure to follow the procedure below when removing the Feed FG Plate.

Install the Sensor ASSY B3, and then fix the harness as shown with the arrows in the photo below.

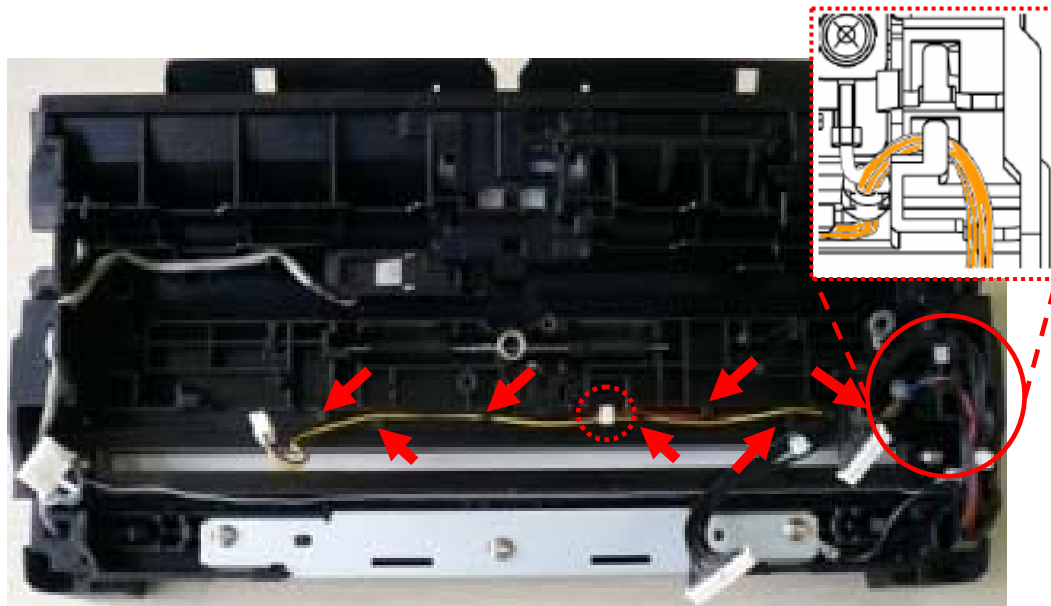

Install the feed plate, and then the Feed FG Plate.

- * The tapping screw at the right side (tightened with the FG cable) that secures the feed plate has a washer. Do not confuse with the other screws.
- * Install the feed plate and fix the three tapping screws before installing the Feed FG Plate.

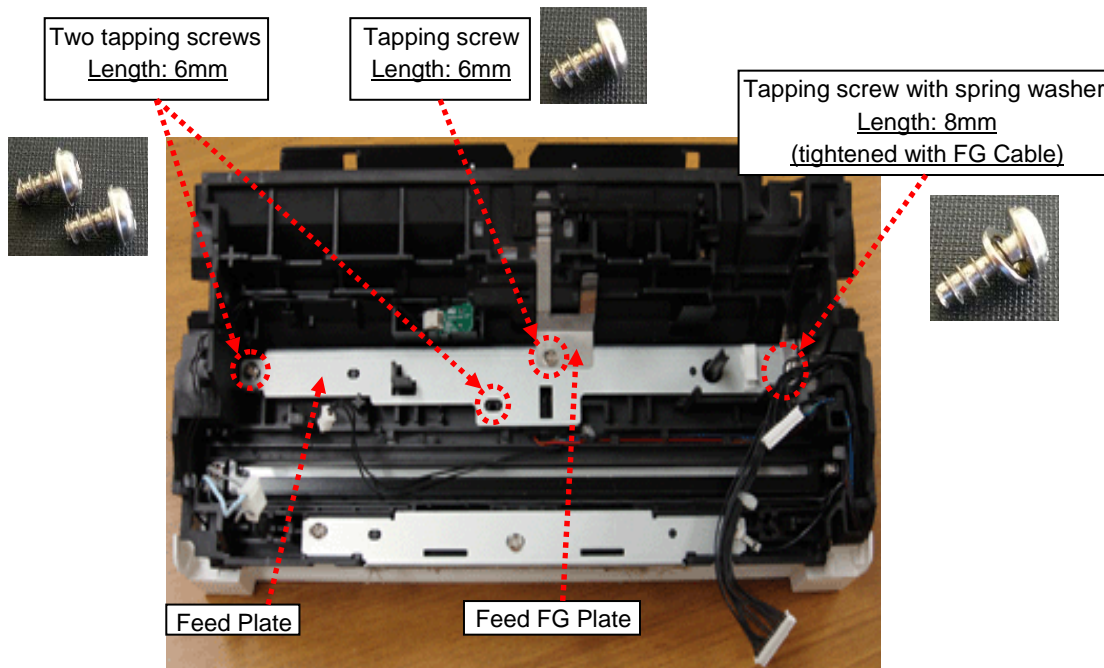

						TITLE	ScanSnap S1500/S1500-SR/S1500M MAINTENANCE MANUAL		
						DRAW. No.	P1PA03586-B00X/6	CUST.	
02	Jan. 23, 2009	K.Okada	T.Anzai	IFujioka	Refer to Revision Record on page 2.				
Rev	DATE	DESIG.	CHECK	APPR.	DESCRIPTION				
DESIG	Jan. 9, 2009	K.Okada	CHECK	T.Anzai	APPR.	IFujioka	PFU LIMITED		PAGE 90/140

When installing the Feed FG Plate, note the following points.

- Thread the Feed FG Plate through the Revolve frame (see the photo below).

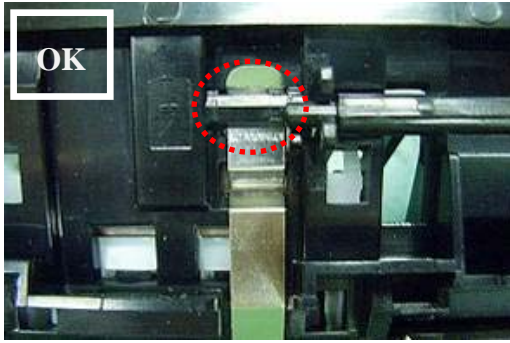

Thread the plate through the Revolve frame.

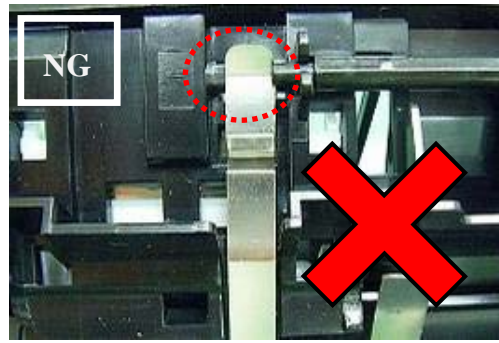

Not thread the plate through the Revolve frame hole. When installing the Feed FG Plate, do not insert the plate into a wrong hole.



The photos below and on the left and below show the results of correct installation.

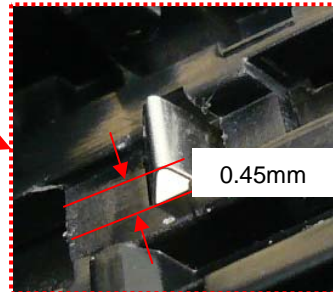

Check that the Feed FG Plate is projected visually. (Projection: 0.45mm)

- When installing the Feed FG Plate, align with the Feed Plate positioning. (Gap: 1mm or less)

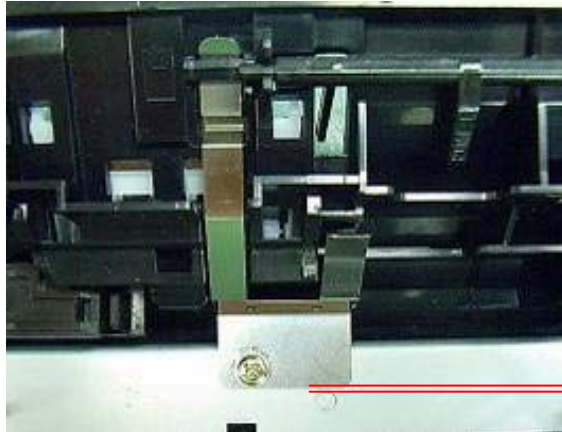

Gap with the positioning: 1mm or less

						TITLE	ScanSnap S1500/S1500-SR/S1500M MAINTENANCE MANUAL			
						DRAW. No.	P1PA03586-B00X/6		CUST.	
02	Jan. 23, 2009	K.Okada	T.Anzai	IFujioka	Refer to Revision Record on page 2.					
Rev	DATE	DESIG.	CHECK	APPR.	DESCRIPTION			PFU LIMITED	PAGE	91/140
DESIG	Jan. 9, 2009	K.Okada	CHECK	T.Anzai		APPR.	IFujioka			

- Insert the lock arm into the lock shaft to fix with the Revolve frame.
- Do not insert the lock arm in wrong direction.

Note:
Check that the Feed FG Plate and the Lock shaft touch each other.

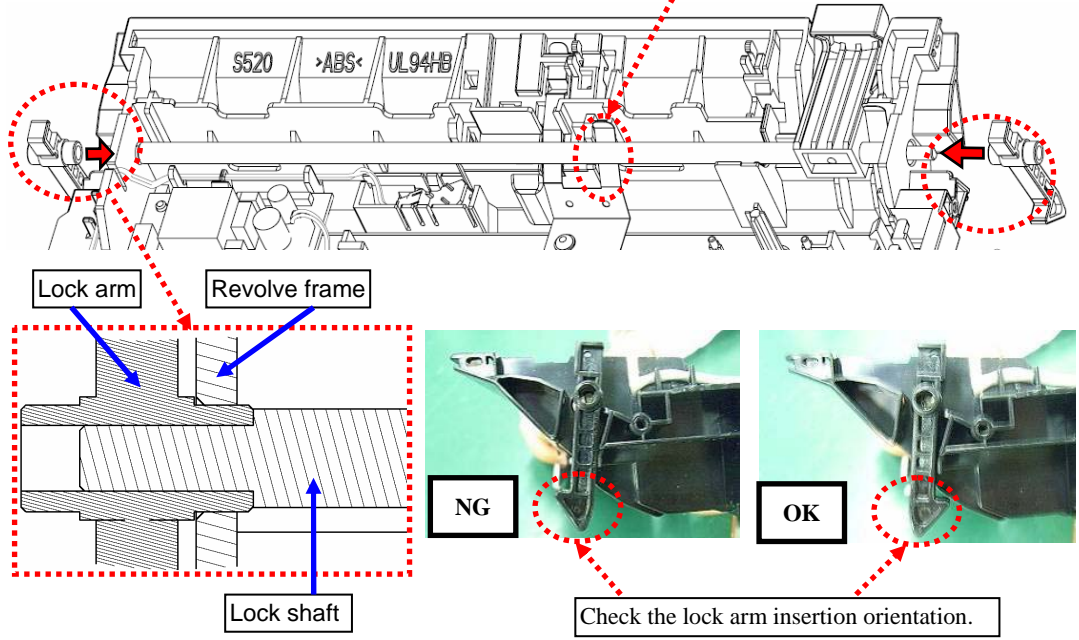

- Install the lock spring in the order of lock arm and then Revolve frame.

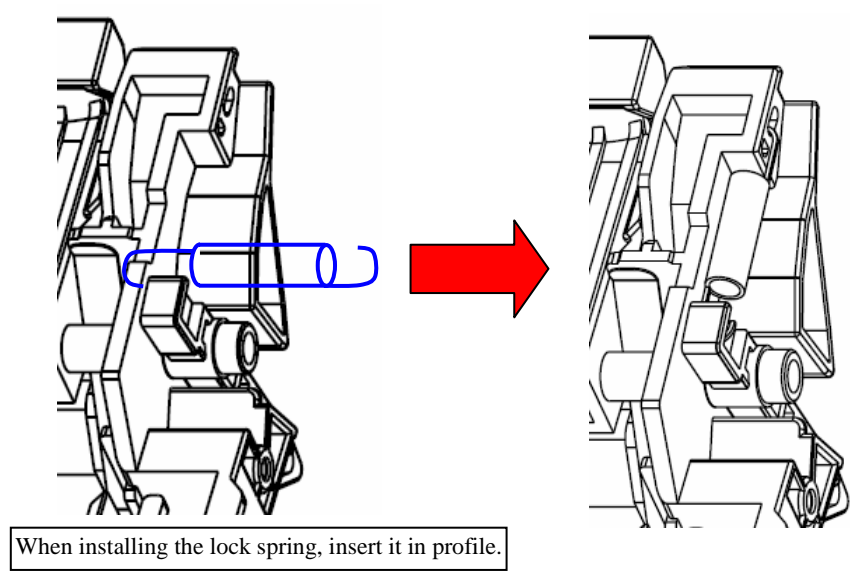

						TITLE	ScanSnap S1500/S1500-SR/S1500M MAINTENANCE MANUAL		
						DRAW. No.	P1PA03586-B00X/6	CUST.	
02	Jan. 23, 2009	K.Okada	T.Anzai	I.Fujioka	Refer to Revision Record on page 2.				
Rev	DATE	DESIG.	CHECK	APPR.	DESCRIPTION				
DESIG	Jan. 9, 2009	K.Okada	CHECK	T.Anzai	APPR.	I.Fujioka	PFU LIMITED		PAGE 92/140

- Install the Inverter, and then check that the cables route as shown in the photo below.

Cable Route 1 (front of Revolve Unit)

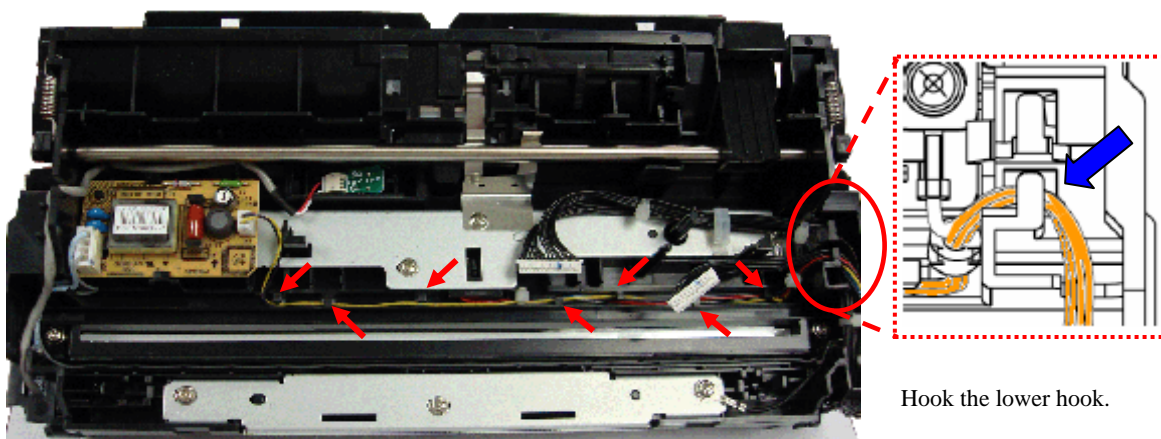

Cable Route 2 (Side of Revolve Unit + Fixed Unit)

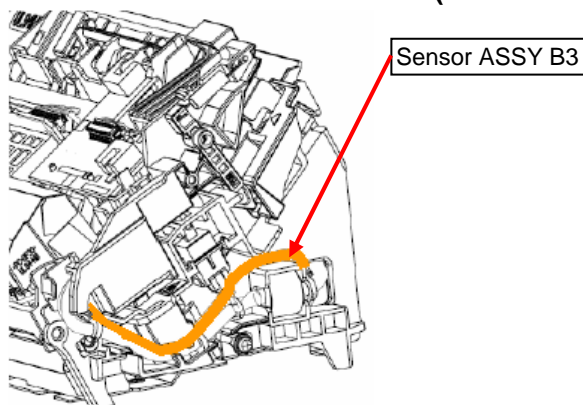

- Check the conduction between the Pad ASSY and the Feed Plate.
 Conduction check between Pad ASSY ⇔ Feed FG Plate ⇔ Feed Plate
 Some areas of the Pad ASSY are not conducting. By referring to the photo below, check the conduction between the conducting area of the Pad ASSY and the Feed FG Plate with a tester. If no conduction is confirmed, check that the Feed FG Plate is not deformed.
 Antirust treatment is done on the Feed Plate. If conduction is not easy to check, try on the screw or edge.

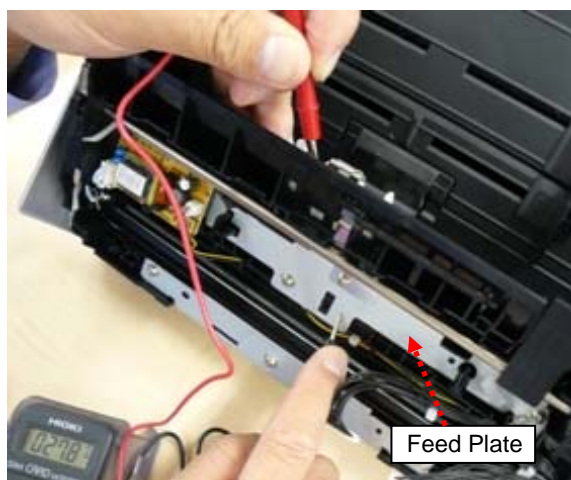
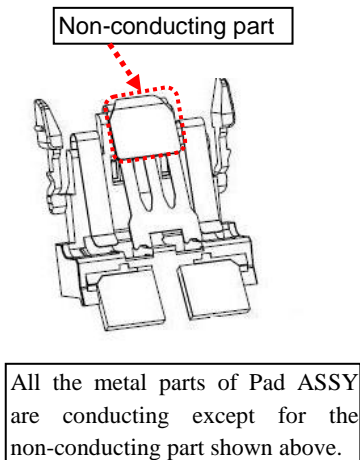

						TITLE	ScanSnap S1500/S1500-SR/S1500M MAINTENANCE MANUAL		
						DRAW. No.	P1PA03586-B00X/6	CUST.	
02	Jan. 23, 2009	K.Okada	T.Anzai	IFujioka	Refer to Revision Record on page 2.				
Rev	DATE	DESIG.	CHECK	APPR.	DESCRIPTION				
DESIG	Jan. 9, 2009	K.Okada	CHECK	T.Anzai	APPR.	IFujioka	PFU LIMITED		PAGE 93/140

- Check the conduction between the lock shaft and FG Plate.
 Conduction check between Lock shaft ⇔ Feed FG Plate ⇔ Feed Plate
 By referring to the photo below, check the conduction between the lock shaft and the Feed Plate with a tester.
 If no conduction is confirmed, check that the Feed FG Plate is not deformed.

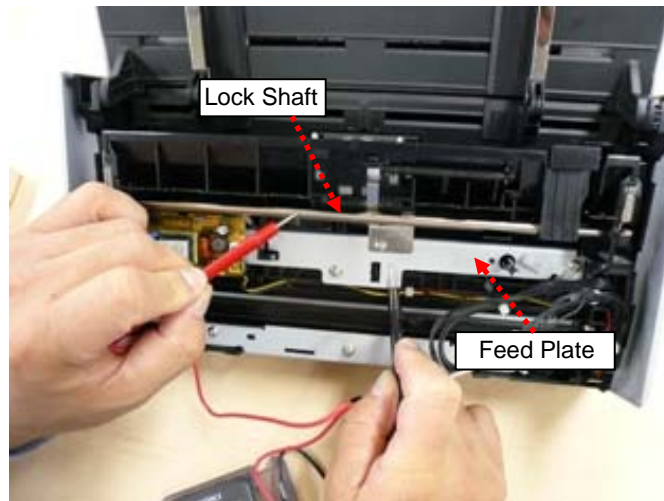

- After replacement, perform the image adjustment. (Refer to Section 6.6.)

						TITLE	ScanSnap S1500/S1500-SR/S1500M MAINTENANCE MANUAL		
						DRAW. No.	P1PA03586-B00X/6	CUST.	
02	Jan. 23, 2009	K.Okada	T.Anzai	IFujioka	Refer to Revision Record on page 2.				
Rev	DATE	DESIG.	CHECK	APPR.	DESCRIPTION				
DESIG	Jan. 9, 2009	K.Okada	CHECK	T.Anzai	APPR.	IFujioka	PFU LIMITED		PAGE 94/140

5.11.7 US Sensor RV

NOTICE

Refer to Section 3.2.6 for the part number of Sensor ASSY B3.

<Removal>

- (1) Remove the following parts.
 - Stacker ASSY: Section 5.6.3
 - Top Cover ASSY: Steps (2) ~ (3) in Section 5.11.1
 - Panel PCA: Steps (3) ~ (4) in Section 5.11.2
 - Optical Unit: Steps (2) ~ (3) in Section 5.11.3
- (2) Remove the US Sensor holder.

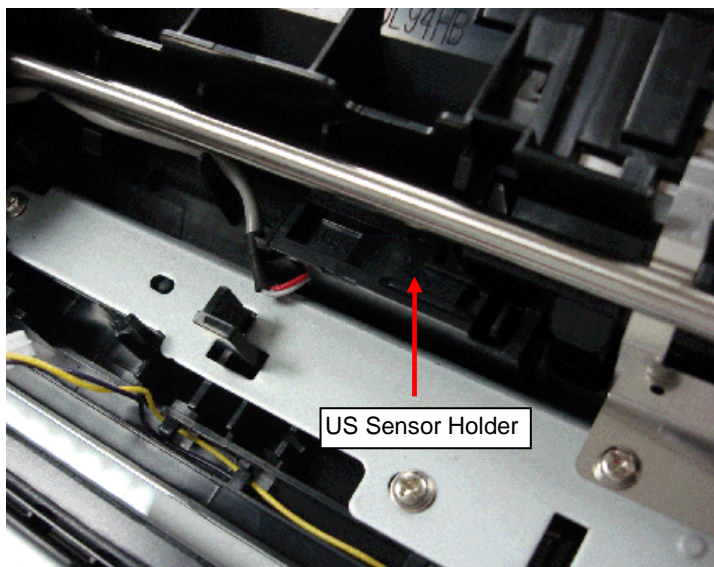

- (3) Pull the cable while widening the frame border, and remove the US Sensor RV.

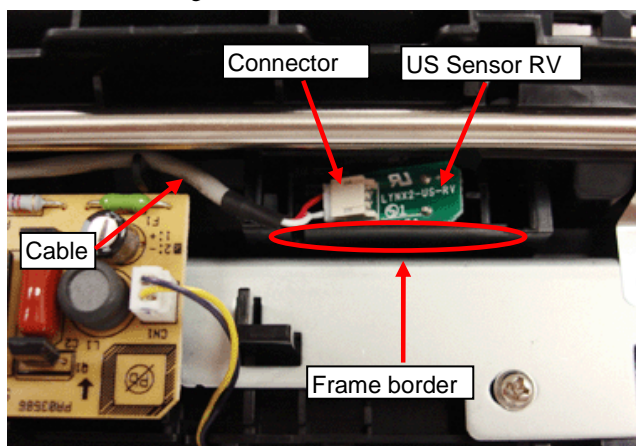

- (4) Disconnect the connector from the US Sensor RV.

<Installation>

Follow the above procedure in reverse order.

NOTICE

Note the following points.

- Confirm that the US Sensor RV is secured with a click sound.
- After replacement, perform the image adjustment. (Refer to Section 6.6.)

						TITLE	ScanSnap S1500/S1500-SR/S1500M MAINTENANCE MANUAL		
						DRAW. No.	P1PA03586-B00X/6	CUST.	
02	Jan. 23, 2009	K.Okada	T.Anzai	IFujioka	Refer to Revision Record on page 2.				
Rev	DATE	DESIG.	CHECK	APPR.	DESCRIPTION				
DESIG	Jan. 9, 2009	K.Okada	CHECK	T.Anzai	APPR.	IFujioka	PFU LIMITED		PAGE 95/140

5.12 Replacing the Fixed Unit / Revolve Unit

NOTICE

1. Before removing the Revolve Unit, save the Log data. (Refer to Section 6.3.)
2. Refer to the following sections for the part numbers of the maintenance parts.
 Fixed Unit: Section 3.2.9
 Revolve Unit: Section 3.2.1

<Removal>

- (1) Remove the following parts.
 - Stacker ASSY: Section 5.6.3
 - PCA Unit: Steps (1) ~ (3) in Section 5.7
 - Guide P ASSY: Section 5.6.2
 - LIDCOV ASSY: Section 5.6.1
 - Chute ASSY: Section 5.6.4
 - Base Cover ASSY: Step (2) in Section 5.9
 - Top Cover ASSY: Steps (2) ~ (3) in Section 5.11.1
 - Guide A: Step (2) in Section 5.8
- (2) Remove the screw that secures the FG Cable from the side of the Fixed Unit.
- (3) Disconnect the Cover Open Sensor connector.

NOTICE

The Cover Open Sensor connector cable is easy to come off. Do NOT hold and pull it.

- (4) Pull the cables at the Revolve Unit side from the Fixed Unit.

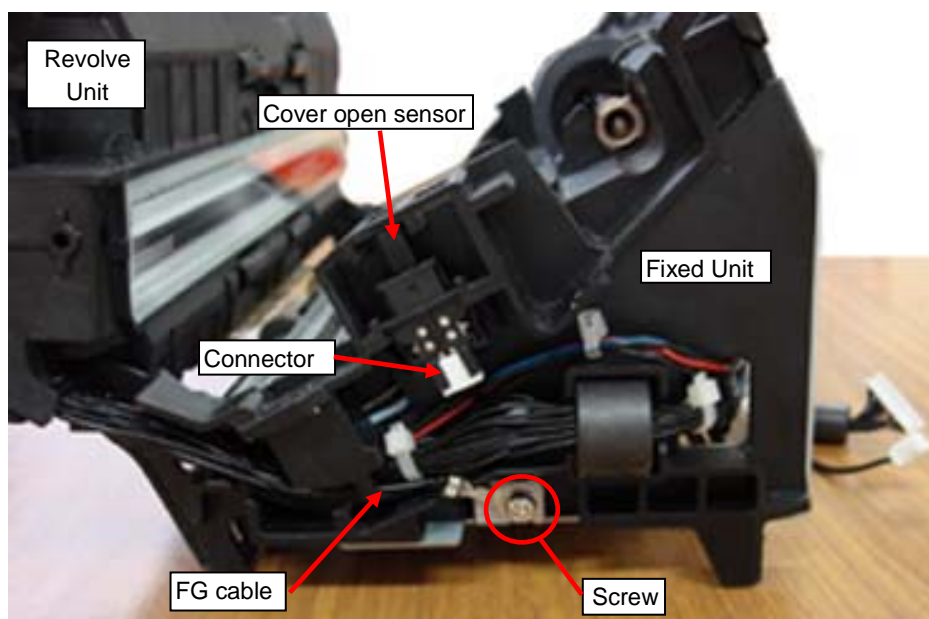

						TITLE	ScanSnap S1500/S1500-SR/S1500M MAINTENANCE MANUAL		
						DRAW. No.	P1PA03586-B00X/6	CUST.	
02	Jan. 23, 2009	K.Okada	T.Anzai	IFujioka	Refer to Revision Record on page 2.				
Rev	DATE	DESIG.	CHECK	APPR.	DESCRIPTION		PFU LIMITED	PAGE	96/140
DESIG	Jan. 9, 2009	K.Okada	CHECK	T.Anzai		APPR. IFujioka			

- (5) At the bottom of the Fixed Unit, remove the tapping screw that secure the FG cable, and then pull the US RV cable out of the Fixed Unit.

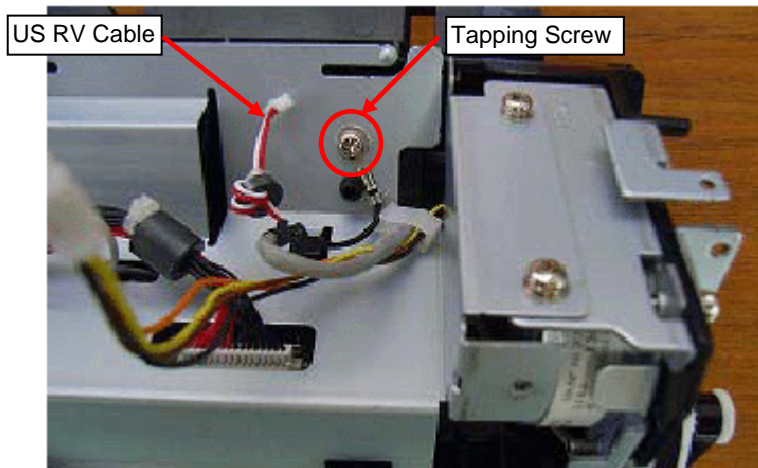

- (6) Insert a flat-blade screwdriver into the gap near the fulcrum pin (left side) to unlatch one side of the pin from the hole. Unlatch the pin on the other side.

<Left Side>

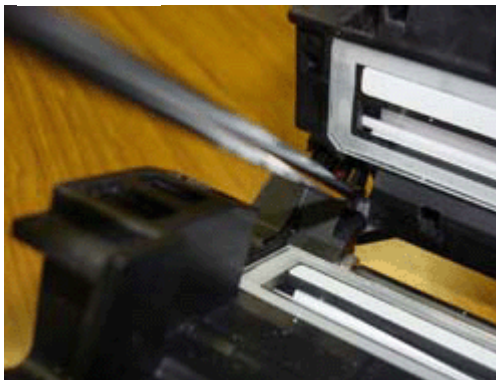

<Right Side>

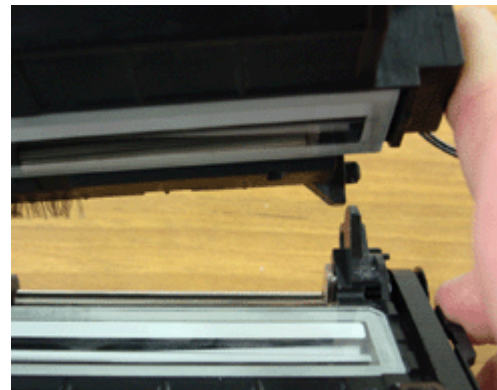

- (7) Separate the Revolve Unit and Fixed Unit.

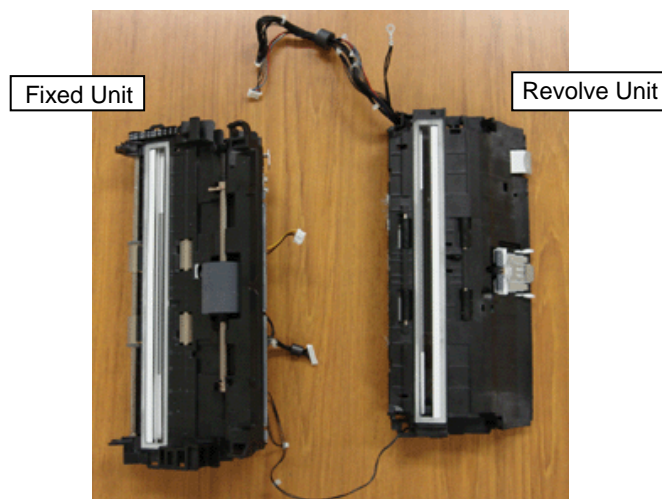

- (8) Install the Top Cover ASSY, which was removed in step (1), into the Revolve Unit in the procedure above in the reverse order.

						TITLE	ScanSnap S1500/S1500-SR/S1500M MAINTENANCE MANUAL			
						DRAW. No.	P1PA03586-B00X/6	CUST.		
02	Jan. 23, 2009	K.Okada	T.Anzai	IFujioka	Refer to Revision Record on page 2.					
Rev	DATE	DESIG.	CHECK	APPR.	DESCRIPTION			PFU LIMITED	PAGE	97/140
DESIG	Jan. 9, 2009	K.Okada	CHECK	T.Anzai		APPR.	IFujioka			

<Installation of Fixed Unit and Revolve Unit>

Follow the above procedure in reverse order.

NOTICE

Note the following points when installing the Fixed Unit and Revolve Unit.

- When installing the shield plate, if wrong cables or clamps are allocated, radio wave specifications may not be satisfied. By referring to Section 5.14.1, be sure to allocate the cables and clamps properly.
- When installing the PCB-UNIT, if a wrong cable is connected, radio wave specification may not be satisfied. By referring to Section 5.14.2, be sure to connect the cables properly.

- Route the cables as shown in the photo below.



- There are a few types of screws. Do not install the wrong type.
- Refer to Section 5.13.3 for the cable installation order and clamp positions after installing the shield plate
- The Fixed Unit includes the Pick Roller. After replacing the Fixed unit, reset the Pick Roller counter. (Refer to Section 7.3.2. and 7.3.3.) The Revolve Unit includes the Pad ASSY. After replacing the Pad ASSY, reset the Pad counter. (Refer to Section 7.3.2 and 7.3.4.)
- After replacing the Revolve Unit, restore the Log data that have been saved before replacing the Revolve Unit (refer to Section 6.4) before performing the image adjustment.
- After replacing the Revolve Unit or Fixed Unit, perform the image adjustment. (Refer to Section 6.6.)

						TITLE	ScanSnap S1500/S1500-SR/S1500M MAINTENANCE MANUAL		
						DRAW. No.	P1PA03586-B00X/6		CUST.
02	Jan. 23, 2009	K.Okada	T.Anzai	IFujioka	Refer to Revision Record on page 2.				
Rev	DATE	DESIG.	CHECK	APPR.	DESCRIPTION			PFU LIMITED	PAGE 98/140
DESIG	Jan. 9, 2009	K.Okada	CHECK	T.Anzai		APPR.	IFujioka		

5.13 Adjusting Belt Tension

NOTICE

1. When replacing the following maintenance parts, tension adjustment is required after installing the belts.
 - Exit Roller: Section 3.2.15
 - Motor: Section 3.2.11
 - Feed Roller: Section .3.2.14
2. A spring gauge is required for belt tension adjustment.
3. The two belt positions are as shown in the illustration below.

Belt Positions (side of Fixed Unit)

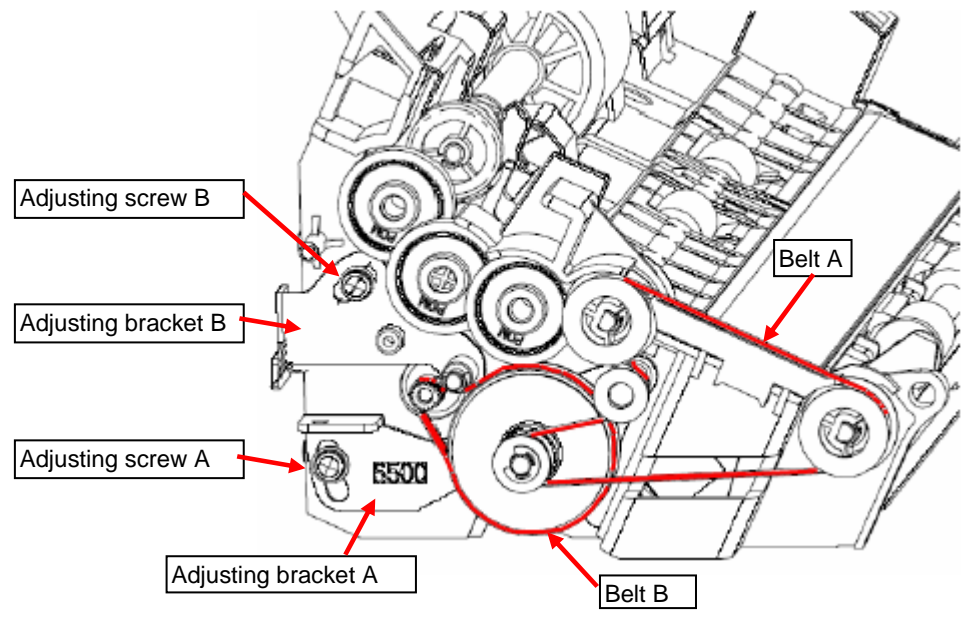

NOTICE

When wiring the cables, follow the procedure and notes in the sections below.

						TITLE	ScanSnap S1500/S1500-SR/S1500M MAINTENANCE MANUAL	
						DRAW. No.	P1PA03586-B00X/6	CUST.
02	Jan. 23, 2009	K.Okada	T.Anzai	IFujioka	Refer to Revision Record on page 2.			
Rev	DATE	DESIG.	CHECK	APPR.	DESCRIPTION			
DESIG	Jan. 9, 2009	K.Okada	CHECK	T.Anzai	APPR.	IFujioka		
						PFU LIMITED	PAGE	99/140

5.13.1 Adjusting Belt A

- (1) Fix the adjusting bracket A with the adjusting screw A by pushing with the power of $750 \pm 50g$.

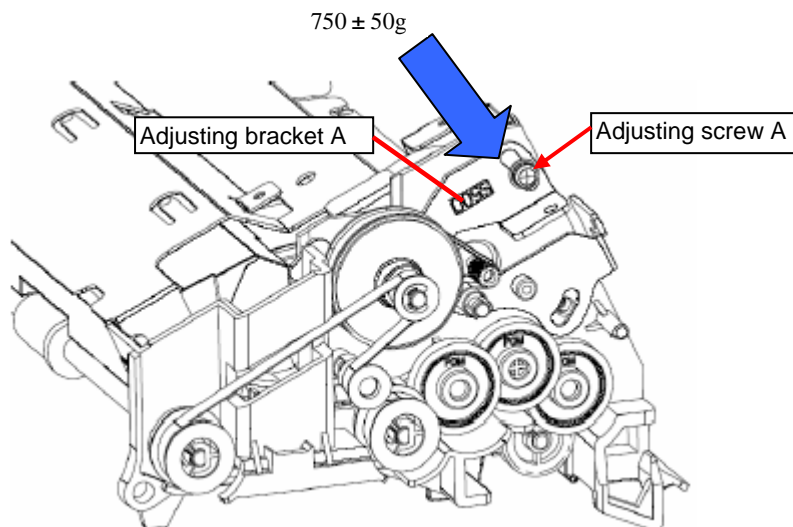

- (2) Confirm that the weight when the belt is pressed in the direction of the arrow is the following. If the value is different, retry step (1) to readjust.

Warp: 3mm
F1: $300 \pm 50g$

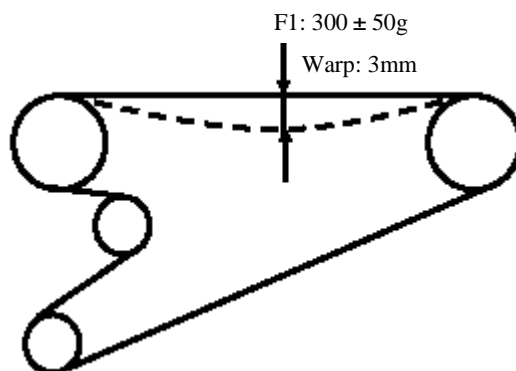
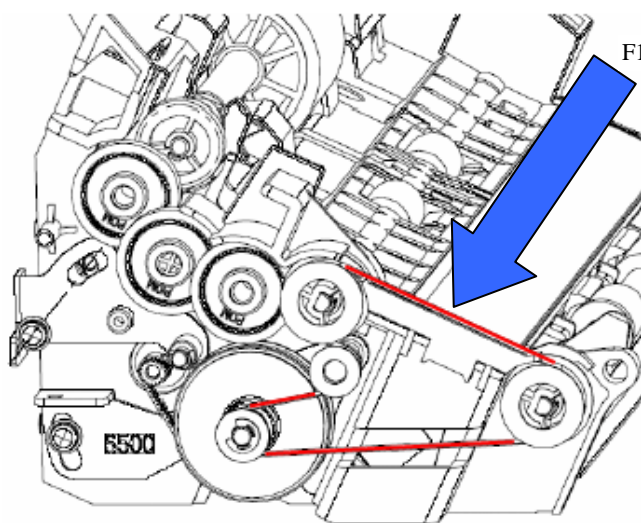

						TITLE	ScanSnap S1500/S1500-SR/S1500M MAINTENANCE MANUAL		
						DRAW. No.	P1PA03586-B00X/6	CUST.	
02	Jan. 23, 2009	K.Okada	T.Anzai	IFujioka	Refer to Revision Record on page 2.				
Rev	DATE	DESIG.	CHECK	APPR.	DESCRIPTION				
DESIG	Jan. 9, 2009	K.Okada	CHECK	T.Anzai	APPR.	IFujioka	PFU LIMITED		PAGE 100/140

5.14 Notes on Installing the Cables and Clamps

5.14.1 Wiring the Shield Plate Section and Clamps

When installing the shield cover, note the following points.

To install the shield cover, insert the six cables into the five holes in the illustration below.

1. US RV cable [Sensor RV ~ Analog PCA (FG cable is on the shield cover)]
2. Motor cable [Motor ~ Analog PCA]
3. CCD cable [Optical Unit ~ Analog PCA]
4. SE cable F2 [US Shield Cover ~ Shield Cover]
5. US FIX cable [US Sensor ~ Analog PCA]
6. SE cable [Inverter ~ Analog PCA]

Cable Route Overview

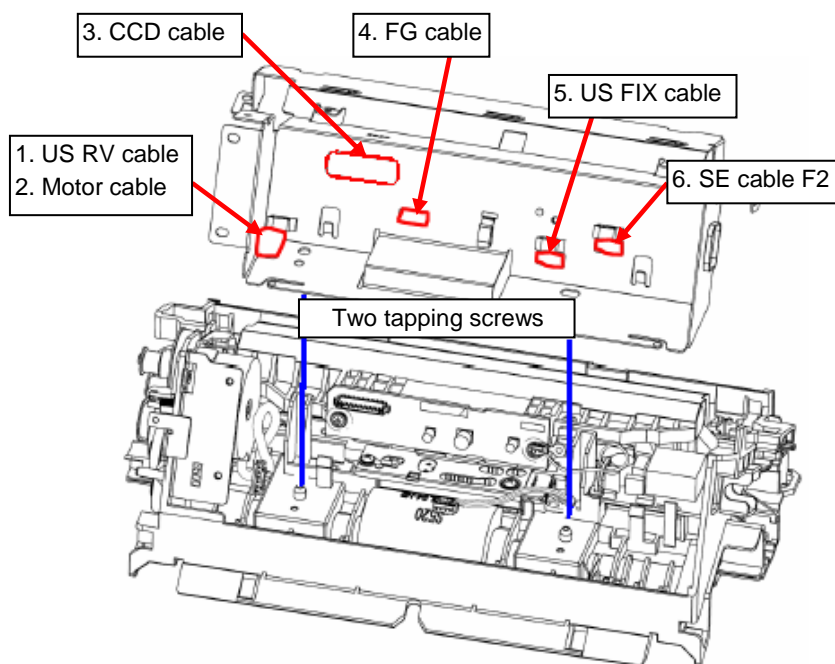

						TITLE	ScanSnap S1500/S1500-SR/S1500M MAINTENANCE MANUAL		
						DRAW. No.	P1PA03586-B00X/6		CUST.
02	Jan. 23, 2009	K.Okada	T.Anzai	IFujioka	Refer to Revision Record on page 2.				
Rev	DATE	DESIG.	CHECK	APPR.	DESCRIPTION			PFU LIMITED	PAGE 102/140
DESIG	Jan. 9, 2009	K.Okada	CHECK	T.Anzai		APPR.	IFujioka		

- (1) Install the US RV cable and clamps.
- Wire the US RV cable, and insert it into the groove on the Fixed frame.

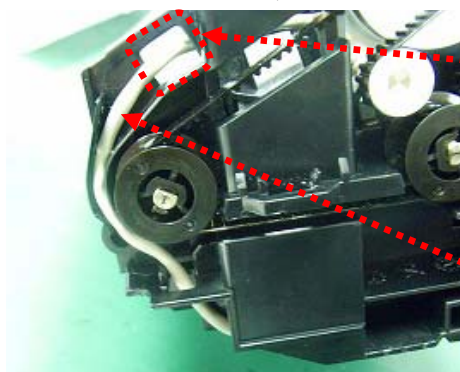

Insert the cable into the hole at the side of the Fixed frame.

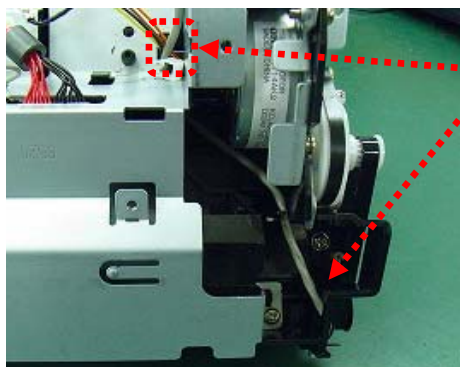

Insert the US RV cable into this hole, and adjust the cable length so that the cable at the side of the Fixed frame is not sagged.

- Tighten the US RV cable with a tapping screw, and then fix it with clamps.

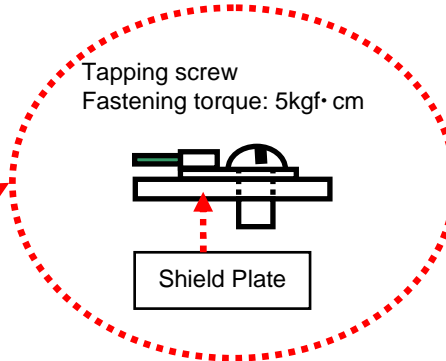
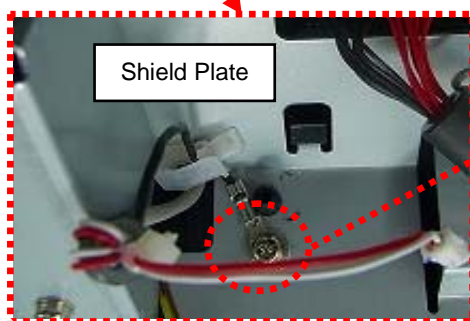
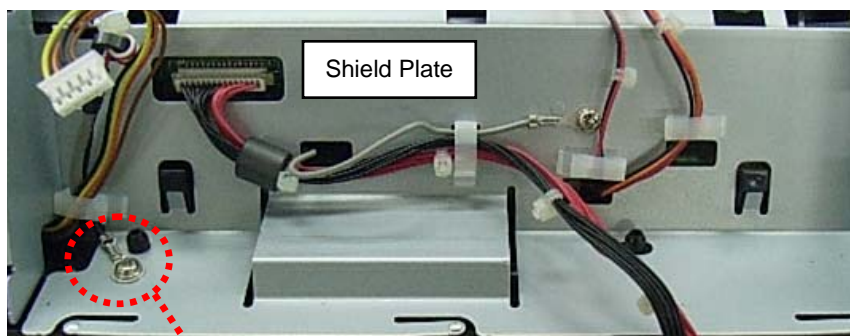

Tapping screw
Fastening torque: 5kgf·cm

Fix the FG cable on the US RV cable as shown in the photo above.

Clamp the FG cable at first so that it comes close to the shield plate.

						TITLE	ScanSnap S1500/S1500-SR/S1500M MAINTENANCE MANUAL			
						DRAW. No.	P1PA03586-B00X/6	CUST.		
02	Jan. 23, 2009	K.Okada	T.Anzai	IFujioka	Refer to Revision Record on page 2.		PFU LIMITED		PAGE	103/140
Rev	DATE	DESIG.	CHECK	APPR.	DESCRIPTION		PFU LIMITED		PAGE	103/140
DESIG	Jan. 9, 2009	K.Okada	CHECK	T.Anzai		APPR.	IFujioka			

- US RV cable clamps
(Install the cable in the correct clamp direction and correct cable position.)

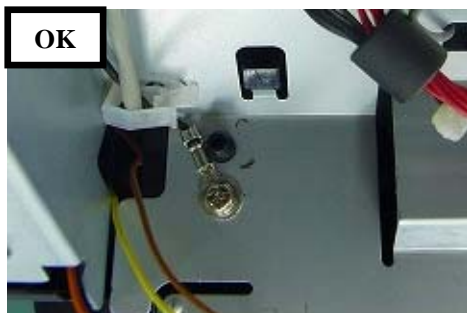

Reverse direction of the clamp



FG cable comes front of the shield wire.

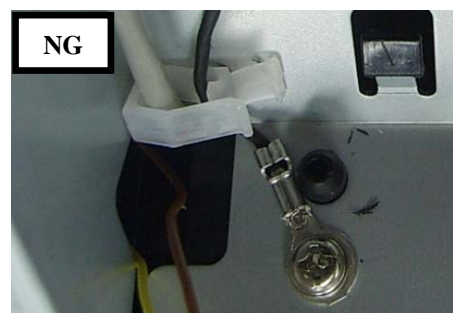

FG cable and shield wire are not close enough.

(2) Motor cable clamp

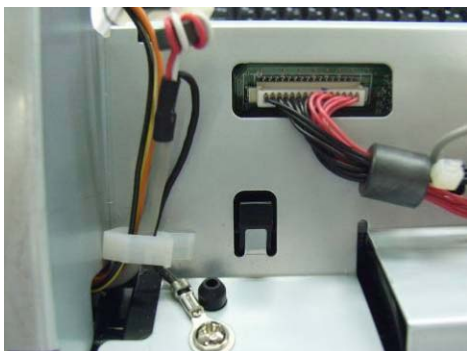

(3) CCD cable clamps

(4) FG cable installation and clamps

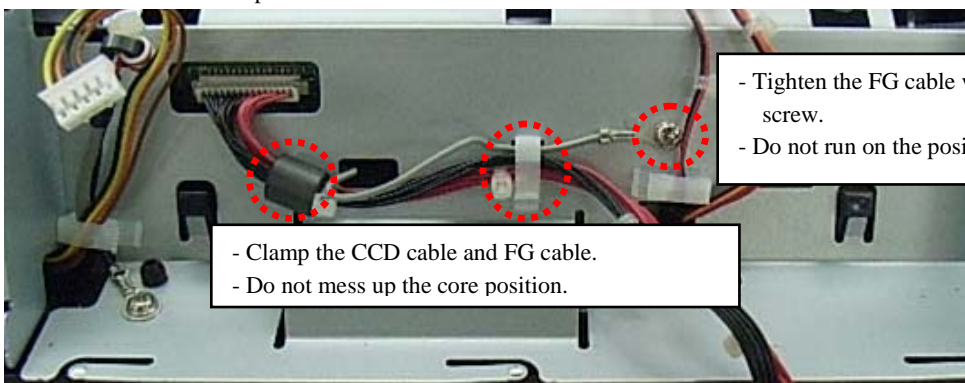

- Clamp the CCD cable and FG cable.
- Do not mess up the core position.

- Tighten the FG cable with a screw.
- Do not run on the positioning pin

						TITLE	ScanSnap S1500/S1500-SR/S1500M MAINTENANCE MANUAL			
						DRAW. No.	P1PA03586-B00X/6	CUST.		
02	Jan. 23, 2009	K.Okada	T.Anzai	IFujioka	Refer to Revision Record on page 2.					
Rev	DATE	DESIG.	CHECK	APPR.	DESCRIPTION			PFU LIMITED	PAGE	104/140
DESIG	Jan. 9, 2009	K.Okada	CHECK	T.Anzai		APPR.	IFujioka			

- (5) US FIX cable
- (6) SE cable F2

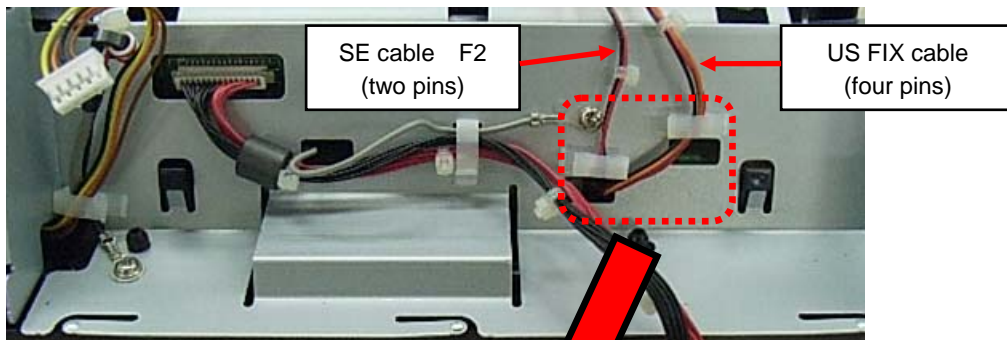

Note: Se cable comes closer to the shield plate than US FIX cable.

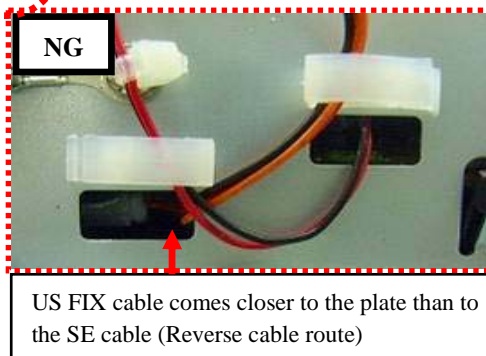
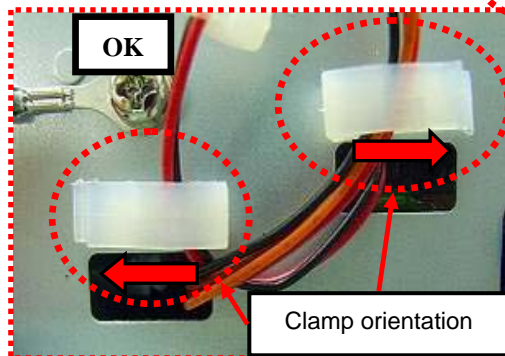

						TITLE	ScanSnap S1500/S1500-SR/S1500M MAINTENANCE MANUAL			
						DRAW. No.	P1PA03586-B00X/6	CUST.		
02	Jan. 23, 2009	K.Okada	T.Anzai	IFujioka	Refer to Revision Record on page 2.					
Rev	DATE	DESIG.	CHECK	APPR.	DESCRIPTION			PFU LIMITED	PAGE	105/140
DESIG	Jan. 9, 2009	K.Okada	CHECK	T.Anzai		APPR.	IFujioka			

5.14.2 Wiring Cables at PCB-UNIT Section

- (1) Install the PCB-UNIT (Control PCA and Analog PCA).
- Cable connection configuration is as follows:
 - **Be sure to refer to the next page for the notes on cable connection.**

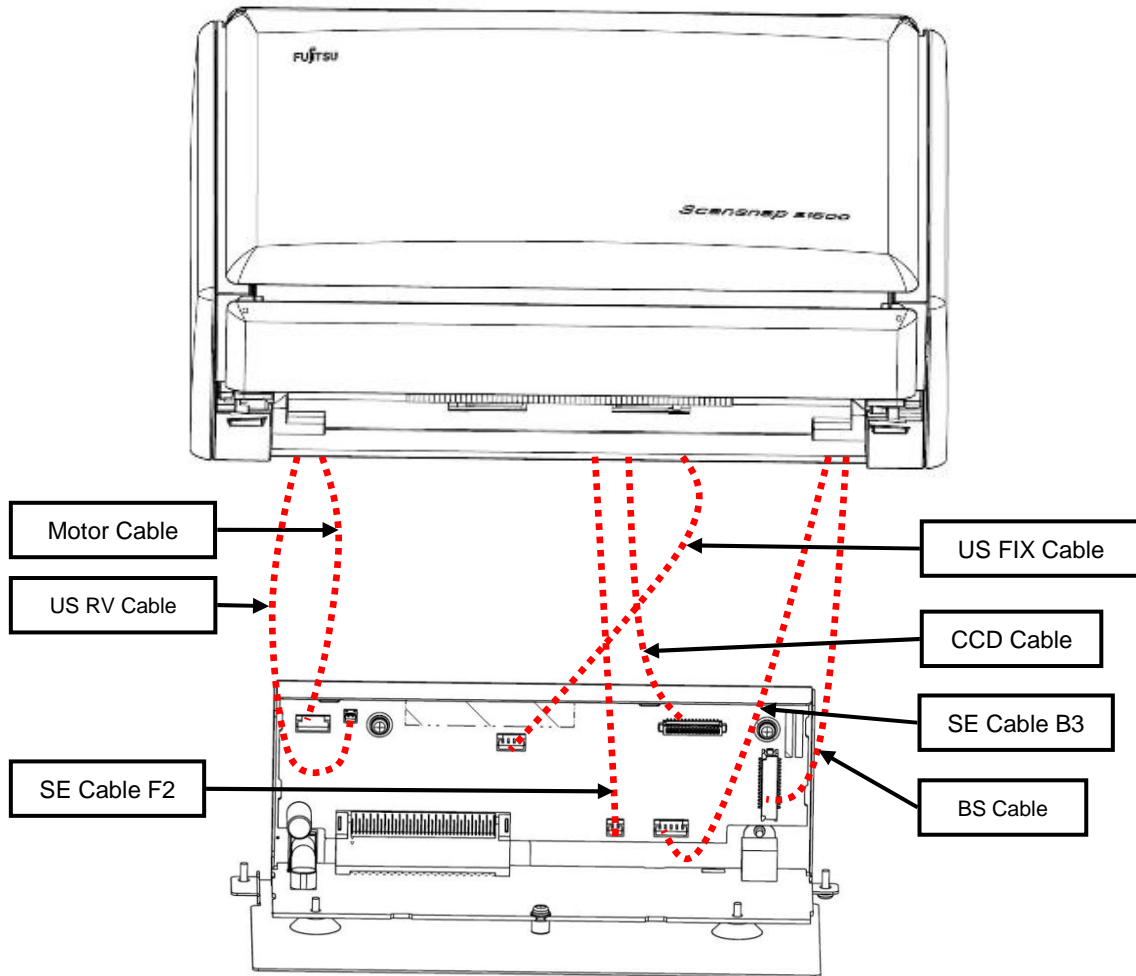

						TITLE	ScanSnap S1500/S1500-SR/S1500M MAINTENANCE MANUAL			
						DRAW. No.	P1PA03586-B00X/6		CUST.	
02	Jan. 23, 2009	K.Okada	T.Anzai	IFujioka	Refer to Revision Record on page 2.					
Rev	DATE	DESIG.	CHECK	APPR.	DESCRIPTION			PFU LIMITED	PAGE	106/140
DESIG	Jan. 9, 2009	K.Okada	CHECK	T.Anzai		APPR.	IFujioka			

(2) Notes on cable connection

- Motor

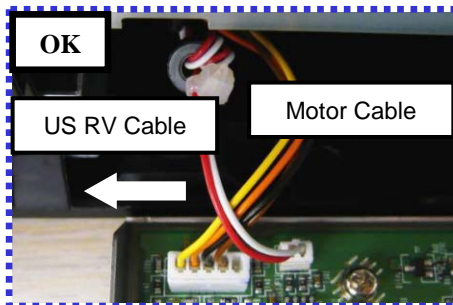

- The US RV cable shall be on the Motor Cable.
- The US RV cable shall be placed in the direction of the arrow on the photo on the left.

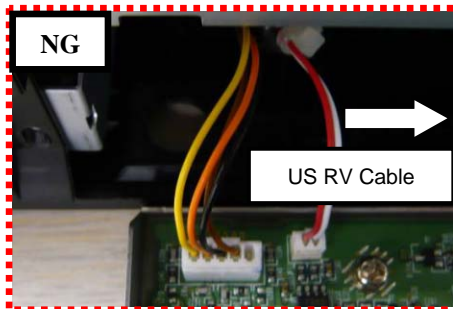

- The US RV Cable and Motor Cable are separated.
- If the US RV cable comes in the direction of the arrow, it comes too close to the CCD cable which may cause radio disturbance or image error.

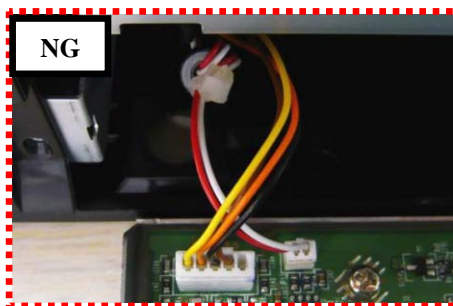

- The positions of the US RV cable and Motor cable are opposite.
- The US RV cable comes under the Motor cable.

						TITLE	ScanSnap S1500/S1500-SR/S1500M MAINTENANCE MANUAL		
						DRAW. No.	P1PA03586-B00X/6	CUST.	
02	Jan. 23, 2009	K.Okada	T.Anzai	IFujioka	Refer to Revision Record on page 2.				
Rev	DATE	DESIG.	CHECK	APPR.	DESCRIPTION				
DESIG	Jan. 9, 2009	K.Okada	CHECK	T.Anzai	APPR.	IFujioka	PFU LIMITED		PAGE 107/140

Chapter 6 Test Program

This chapter describes how to use the Test program provided for this scanner.

Two types of programs are included in the Test program. The names and functions of these programs are as follows.

- 1) ScanSnap EEPROM Maintenance Tool
This program copies the data from the EEPROM on the Panel PCA and saves it to this tool on the PC. It also restores the data onto the EEPROM on the new Panel PCA. (Refer to Sections 1.5.3 and 5.11.2.) This program is also used to refer to EEPROM information.
- 2) Adjustment Tool (hereinafter called "TP-TOWER")
This program is used for the Adjustment of the image after the parts are replaced for Troubleshooting. (Refer to Chapter 5).

6.1 System Environment of Test Program

Host	: Pentium 4, 1.8 GHz or more
Memory	: 512 MB or more
Disk space	: 400 MB or more free space (*1)
Display	: 1024 x 768 dot or more
USB port	: USB 2.0 (mandatory)
CD-ROM drive	: Necessary for driver installation
OS	: Windows 2000/Windows XP
Driver	: ScanSnap Manager V5.0L10 or later

- *1 It is assumed that the Test program files are copied to the HDD. If the files are copied to a different memory drive, an error may occur due to shortage of memory.

						TITLE	ScanSnap S1500/S1500-SR/S1500M MAINTENANCE MANUAL		
						DRAW. No.	P1PA03586-B00X/6		CUST.
02	Jan. 23, 2009	K.Okada	T.Anzai	IFujioka	Refer to Revision Record on page 2.				
Rev	DATE	DESIG.	CHECK	APPR.	DESCRIPTION		PFU LIMITED	PAGE	108/140
DESIG	Jan. 9, 2009	K.Okada	CHECK	T.Anzai		APPR. IFujioka			

6.2 Work Flow of Unit Inspection and Unit Repair

The workflows when using the Test program are as follows:

(1) Troubleshooting

The following shows a procedure for checking scanner image quality.

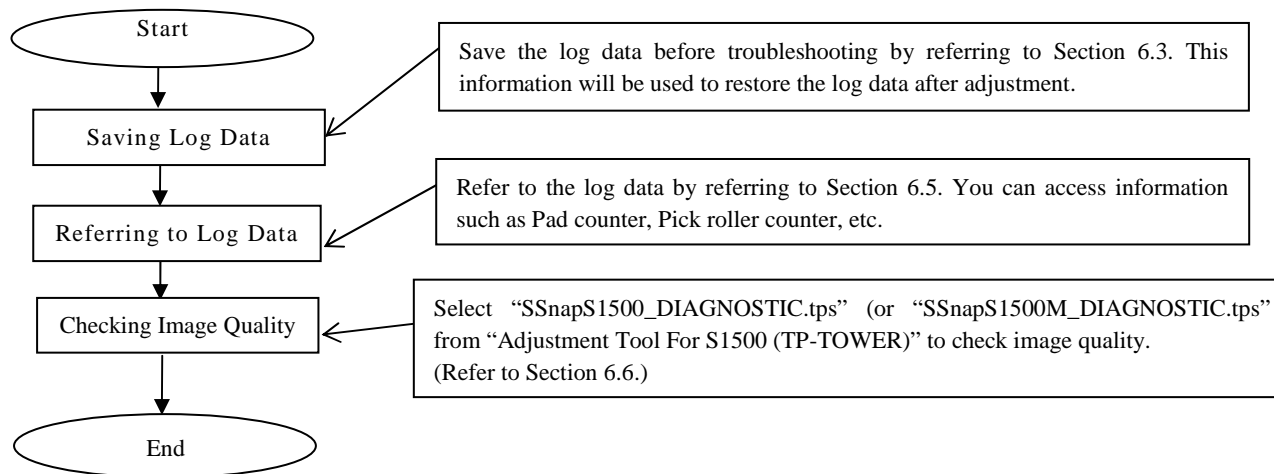

(2) Adjustment

The following shows a procedure for adjusting and checking image quality of a repaired scanner.

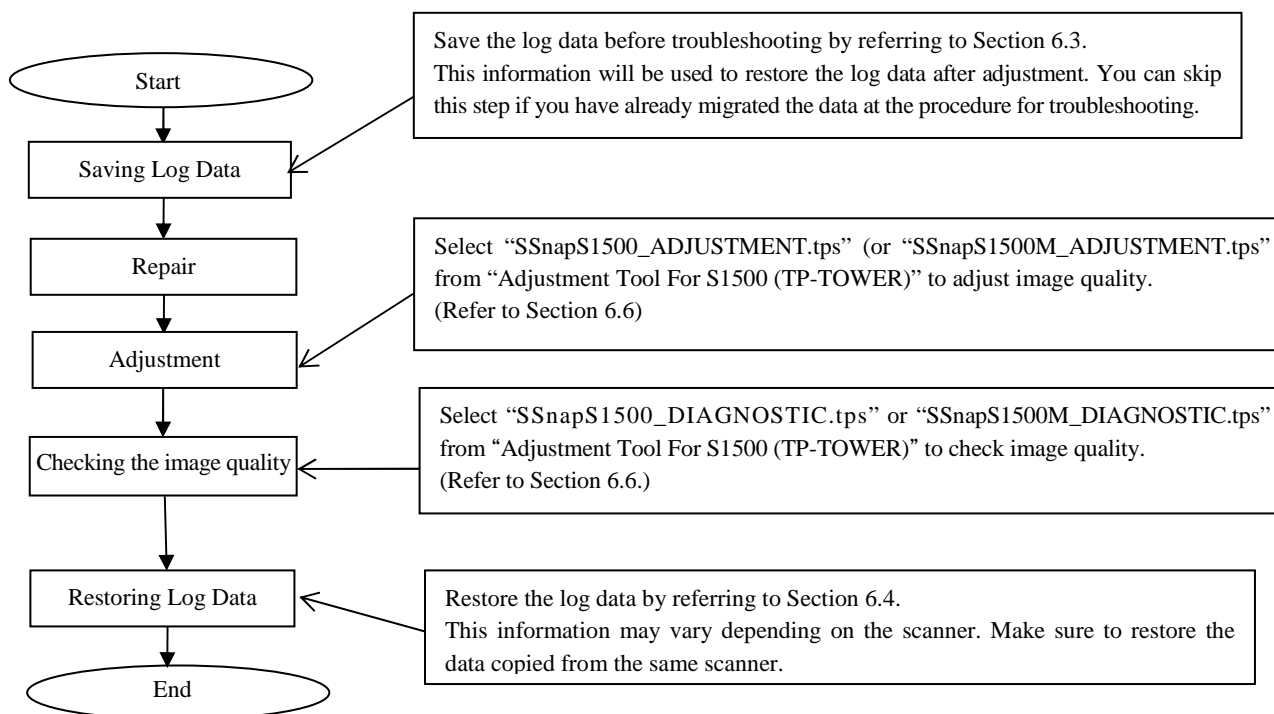

						TITLE	ScanSnap S1500/S1500-SR/S1500M MAINTENANCE MANUAL		
						DRAW. No.	P1PA03586-B00X/6		CUST.
02	Jan. 23, 2009	K.Okada	T.Anzai	IFujioka	Refer to Revision Record on page 2.				
Rev	DATE	DESIG.	CHECK	APPR.	DESCRIPTION	PFU LIMITED		PAGE	109/140
DESIG	Jan. 9, 2009	K.Okada	CHECK	T.Anzai		APPR.	IFujioka		

6.3 How to Save EEPROM Data

The following procedure is used to copy the EEPROM data stored in the OP Panel and save it temporarily on the PC. This is the required procedure before OP Panel replacement.

- 1) Activate "SSNAPE2P.exe".
- 2) Click the [Save History Info.] button.



						TITLE	ScanSnap S1500/S1500-SR/S1500M MAINTENANCE MANUAL		
						DRAW. No.	P1PA03586-B00X/6		CUST.
02	Jan. 23, 2009	K.Okada	T.Anzai	IFujioka	Refer to Revision Record on page 2.				
Rev	DATE	DESIG.	CHECK	APPR.	DESCRIPTION			PFU LIMITED	PAGE 110/140
DESIG	Jan. 9, 2009	K.Okada	CHECK	T.Anzai		APPR.	IFujioka		

- 3) Specify the file name to save the data to and click the [Save] button. The EEPROM data will be saved in the specified file, and the message on step (4) appears.

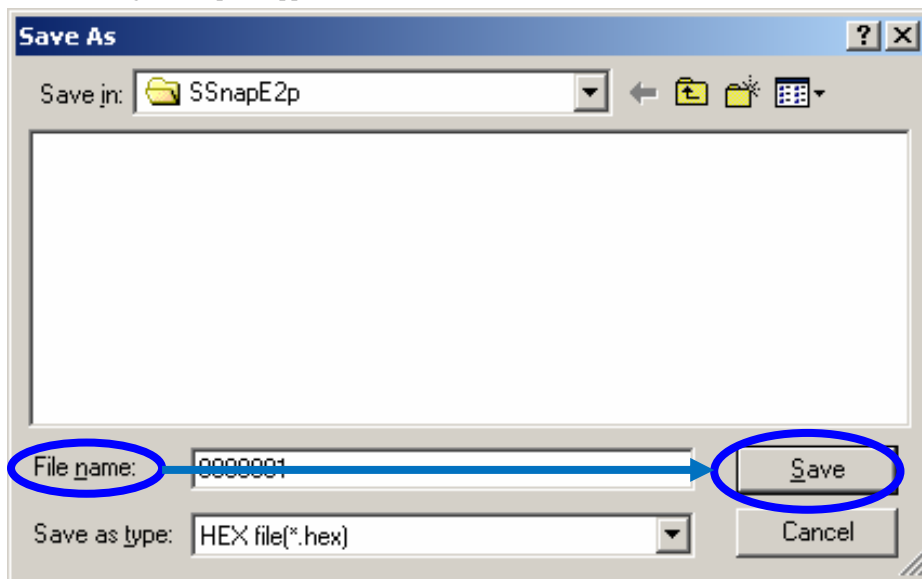

NOTICE

1. It is recommended to use the Serial Number of the ScanSnap that is being repaired as the file name.
2. The Log data is saved in the Test program folder. Be careful not to delete the Log data.
3. If you specify an existing file name, the warning message asking you whether the data shall be over-written or not is displayed. The EEPROM data is very important, so the message will appear several times to prevent the data from being overwritten by mistake. Respond properly to the messages as shown in the following flow chart.

						TITLE	ScanSnap S1500/S1500-SR/S1500M MAINTENANCE MANUAL		
						DRAW. No.	P1PA03586-B00X/6	CUST.	
02	Jan. 23, 2009	K.Okada	T.Anzai	IFujioka	Refer to Revision Record on page 2.				
Rev	DATE	DESIG.	CHECK	APPR.	DESCRIPTION	PFU LIMITED		PAGE	111/140
DESIG	Jan. 9, 2009	K.Okada	CHECK	T.Anzai	APPR.	IFujioka			

When you have specified an existing file name:

First confirmation appears.

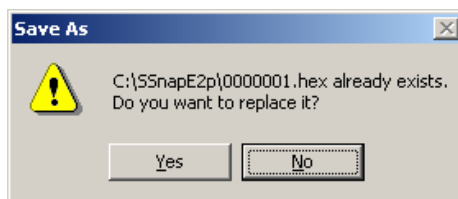

Returns to the screen on step (3).

Click

Click

Second confirmation appears.



Click

Third confirmation appears.

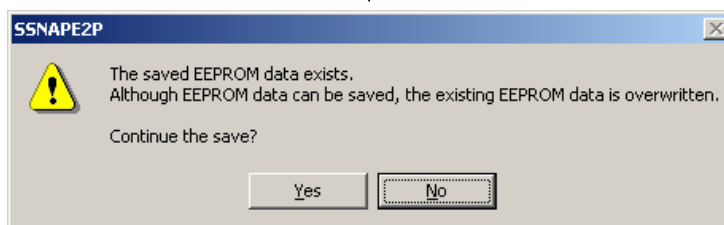

Click

Click

Fourth confirmation appears

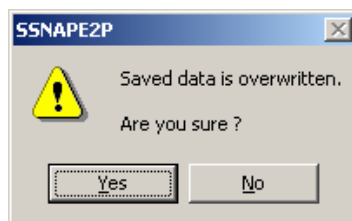

Click

Click

The log data is overwritten.

4) Completes EEPROM data restoration.

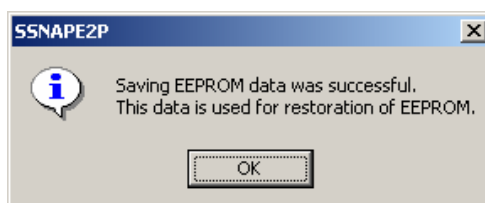

The EEPROM data has been saved when this screen appears. Click the [OK] button.

						TITLE	ScanSnap S1500/S1500-SR/S1500M MAINTENANCE MANUAL		
						DRAW. No.	P1PA03586-B00X/6	CUST.	
02	Jan. 23, 2009	K.Okada	T.Anzai	IFujioka	Refer to Revision Record on page 2.				
Rev	DATE	DESIG.	CHECK	APPR.	DESCRIPTION				
DESIG	Jan. 9, 2009	K.Okada	CHECK	T.Anzai		APPR.	IFujioka	PFU LIMITED	PAGE 112/140

6.4 How to Restore the EEPROM Data

The following explains how to restore the EEPROM data that has been saved on the PC to the EEPROM on the new OP Panel.

- 1) Activate "SSNAPE2P.exe".
- 2) Click the [Restore History Info.] button.

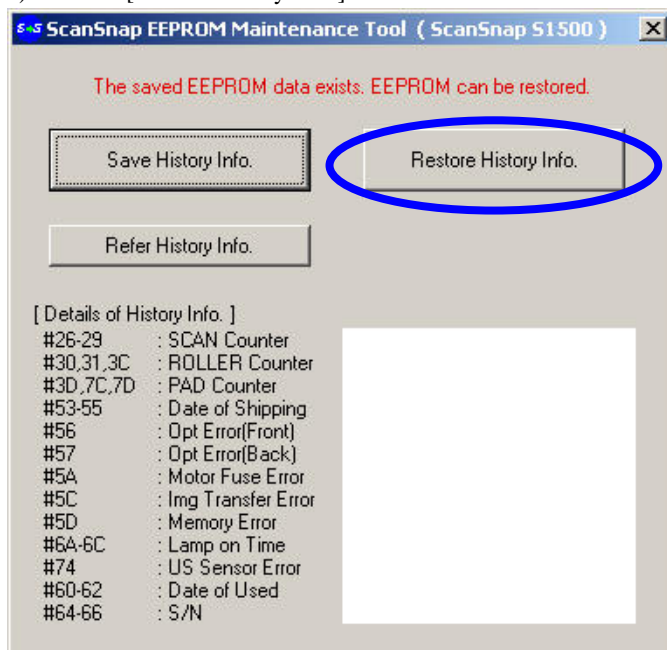

NOTICE

If the EEPROM data that has been saved does not exist, [Restore History Info] button is invalid.

- 3) Specify the file (EEPROM data) to restore, and then click the [Open] button.

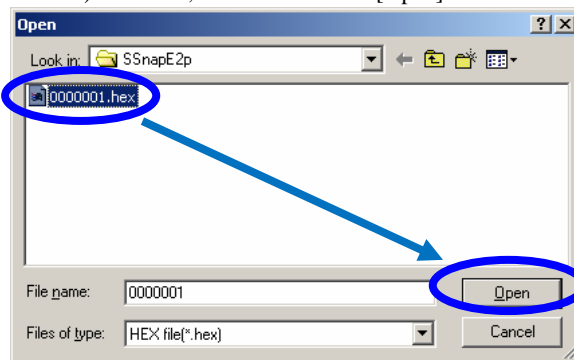

- 4) The screen below will appear to confirm whether the serial number of the EEPROM data and that of the actual ScanSnap are identical.

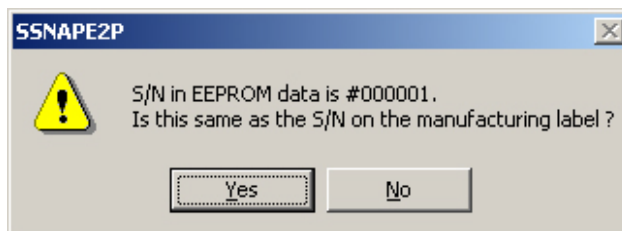

Make sure that the serial numbers on the EEPROM data and the manufacturing label are the same, and then click the [Yes] button. If they are not identical, click the [No] button.

						TITLE	ScanSnap S1500/S1500-SR/S1500M MAINTENANCE MANUAL			
						DRAW. No.	P1PA03586-B00X/6	CUST.		
02	Jan. 23, 2009	K.Okada	T.Anzai	IFujioka	Refer to Revision Record on page 2.					
Rev	DATE	DESIG.	CHECK	APPR.	DESCRIPTION			PFU LIMITED	PAGE	113/140
DESIG	Jan. 9, 2009	K.Okada	CHECK	T.Anzai	APPR. IFujioka					

5) If you clicked the [No] button on step (4), the screen below appears. Click the [OK] button.

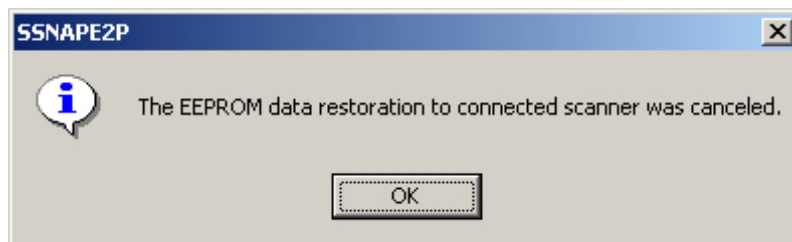

If you clicked [Yes] on step (4), the screen below appears.

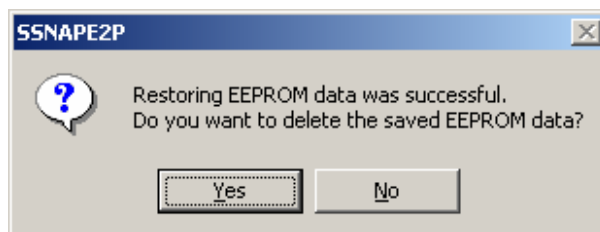

If you click the [Yes] button on this screen, the file specified on step (3) will be deleted.
 If you click the [No] button, the file specified on step (3) will not be deleted.

If there is EEPROM data in remaining in the tool, go back to the screen in step (2).
 If there is not EEPROM data in the tool, go back to the screen in step (2) in Section 6.3.

						TITLE	ScanSnap S1500/S1500-SR/S1500M MAINTENANCE MANUAL		
						DRAW. No.	P1PA03586-B00X/6		CUST.
02	Jan. 23, 2009	K.Okada	T.Anzai	IFujioka	Refer to Revision Record on page 2.		PFU LIMITED		PAGE 114/140
Rev	DATE	DESIG.	CHECK	APPR.	DESCRIPTION				
DESIG	Jan. 9, 2009	K.Okada	CHECK	T.Anzai		APPR.	IFujioka		

6.5 How to Refer to the EEPROM Data

The following explains how to refer to the EEPROM data.

- 1) Activate "SNAPE2P.exe".
- 2) Click the [Refer History Info.] button.

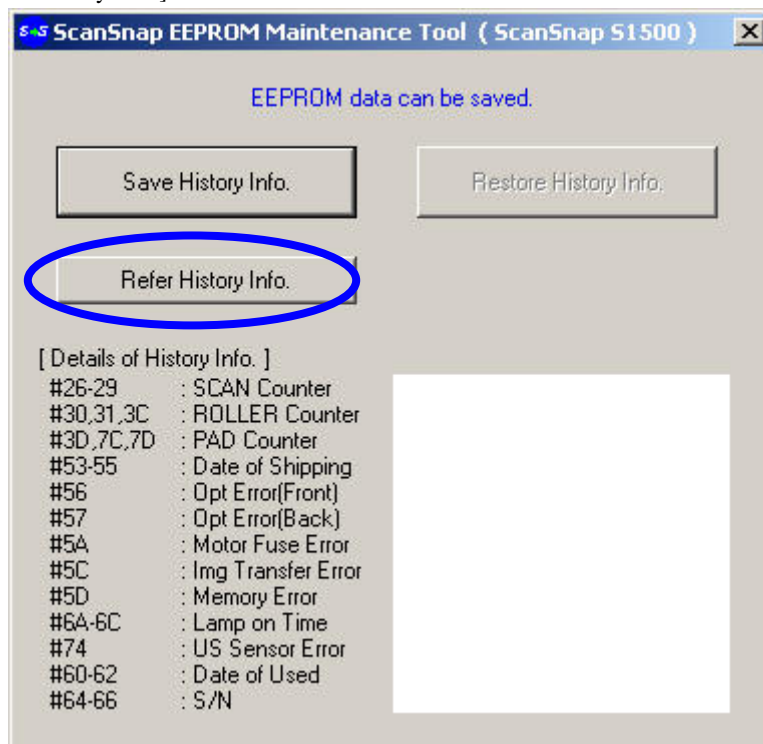

- 3) History information appears.

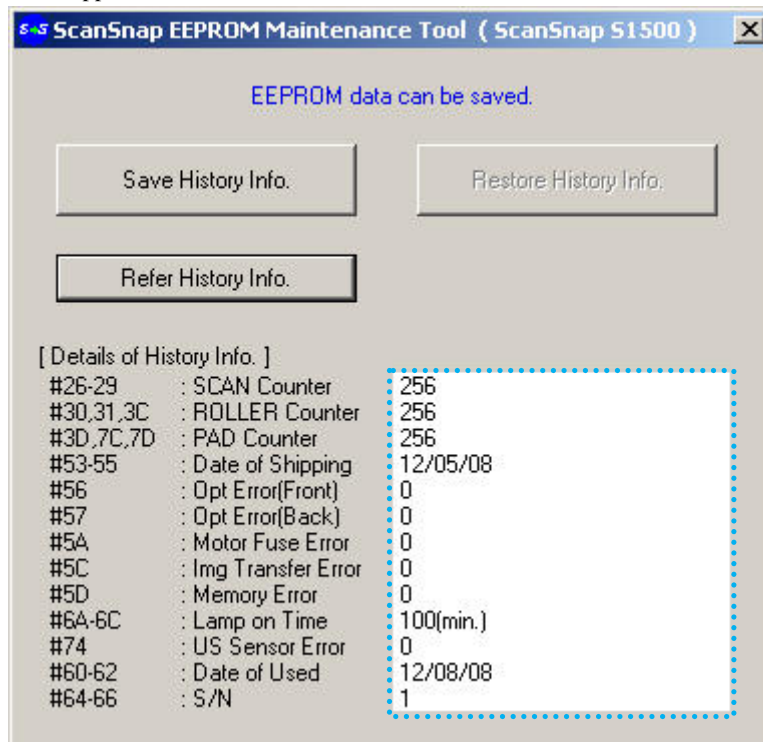

						TITLE	ScanSnap S1500/S1500-SR/S1500M MAINTENANCE MANUAL		
						DRAW. No.	P1PA03586-B00X/6		CUST.
02	Jan. 23, 2009	K.Okada	T.Anzai	IFujioka	Refer to Revision Record on page 2.				
Rev	DATE	DESIG.	CHECK	APPR.	DESCRIPTION		PFU LIMITED	PAGE	115/140
DESIG	Jan. 9, 2009	K.Okada	CHECK	T.Anzai	APPR.	IFujioka			

The contents of the items are as follows:

Displayed Item	Description
SCAN Counter	Displays the number of sheets of documents that have been scanned in the life of the ScanSnap.
ROLLER Counter	Displays how many documents have been scanned since the Pick roller counter was reset using the ScanSnap Manager. When this counter exceeds 100,000, the Pick Roller needs to be replaced.
PAD Counter	Displays how many documents have been scanned since the Pad counter was reset using the ScanSnap Manager. When this counter exceeds 50,000, the Pad ASSY needs to be replaced.
Date of Shipping	Date (dd/mm/yy) on which the ScanSnap test was completed in the factory
Opt Error (Front)	Displays the number of the Optical Unit errors for front side scanning.
Opt Error (Back)	Displays the number of the Optical Unit errors for backside scanning.
Motor Fuse Error	Displays the number of motor fuse errors.
Img Transfer Error	Displays the number of image transfer errors.
Memory Error	Displays the number of memory errors.
Lamp on Time	Displays the lamp lighting period of time.
US Sensor Error	Displays the number of US Sensor errors.
Date of Used	The first date (dd/mm/yy) on which the user used the ScanSnap.
S/N	ScanSnap serial number

						TITLE	ScanSnap S1500/S1500-SR/S1500M MAINTENANCE MANUAL		
						DRAW. No.	P1PA03586-B00X/6	CUST.	
02	Jan. 23, 2009	K.Okada	T.Anzai	IFujioka	Refer to Revision Record on page 2.				
Rev	DATE	DESIG.	CHECK	APPR.	DESCRIPTION	PFU LIMITED		PAGE	116/140
DESIG	Jan. 9, 2009	K.Okada	CHECK	T.Anzai		APPR.	IFujioka		

6.6 How to Use the TP-TOWER

The following explains how to adjust and check the image quality.

Note: Prepare the following Test Charts to adjust and test the image quality.

Description	P/N	Remarks
Test Chart No.42	PA03277-Y120	Refer to Section 5.4.
Test Sheet (W)	PA03277-Y123	

- 1) Run ttatp.exe to activate TP-TOWER.
- 2) The screen below appears. Select ScanSnap S1500 or ScanSnap S1500M, and click the [OK] button.

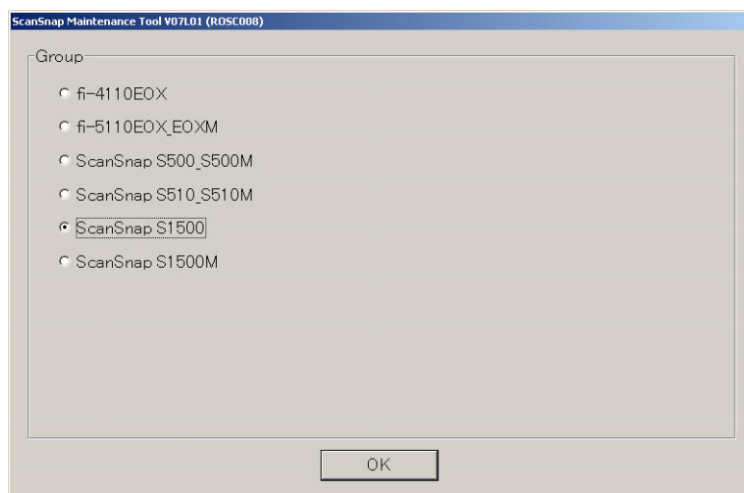

- 3) Click the [Select] button on the screen below.

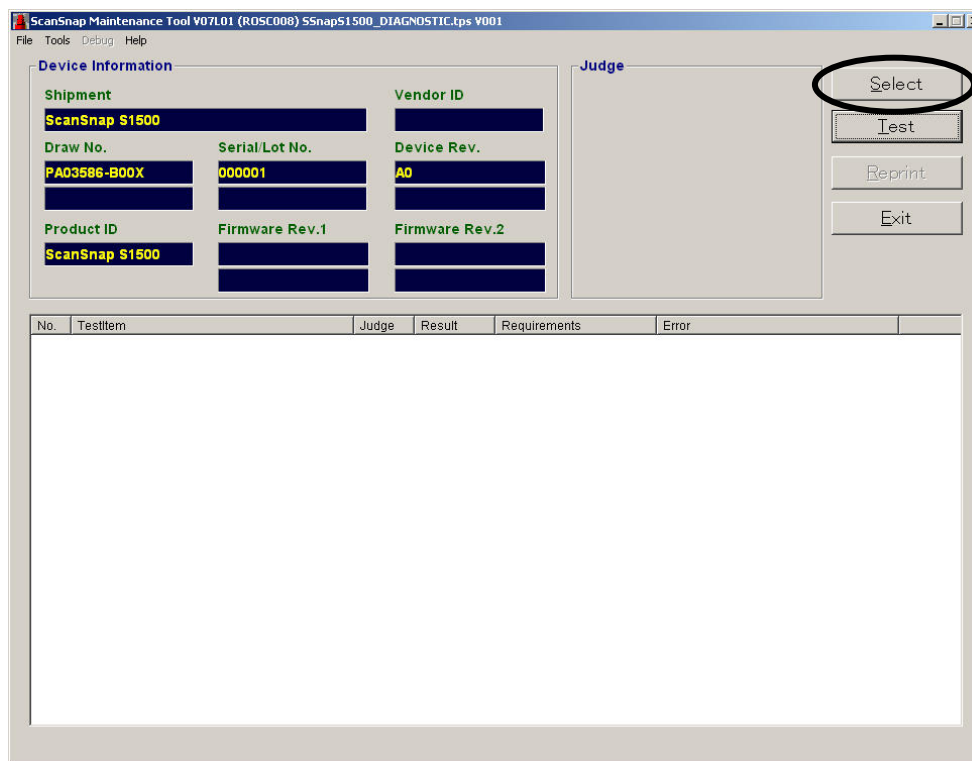

						TITLE	ScanSnap S1500/S1500-SR/S1500M MAINTENANCE MANUAL			
						DRAW. No.	P1PA03586-B00X/6		CUST.	
02	Jan. 23, 2009	K.Okada	T.Anzai	IFujioka	Refer to Revision Record on page 2.					
Rev	DATE	DESIG.	CHECK	APPR.	DESCRIPTION			PFU LIMITED	PAGE	117/140
DESIG	Jan. 9, 2009	K.Okada	CHECK	T.Anzai		APPR.	IFujioka			

4) Select a process you want to perform.

- SSnapS1500_DIAGNOSTIC.tps or SSnapS1500M_DIAGNOSTIC.tps: Troubleshooting
- SSnapS1500_ADJSUTMENT.tps or SSnapS1500M_ADJUSTMENT.tps: Adjustment

Input the following items:

1. Serial/Lot No.: Input the serial number of the ScanSnap.
2. Revision: Input the revision number of the ScanSnap.
3. Product Year/Month: Input the manufactured year/month described on the ScanSnap.

Click the [OK] button after the entry. Test program returns to the screen on step (3).

						TITLE	ScanSnap S1500/S1500-SR/S1500M MAINTENANCE MANUAL		
						DRAW. No.	P1PA03586-B00X/6		CUST.
02	Jan. 23, 2009	K.Okada	T.Anzai	IFujioka	Refer to Revision Record on page 2.				
Rev	DATE	DESIG.	CHECK	APPR.	DESCRIPTION	PFU LIMITED		PAGE	118/140
DESIG	Jan. 9, 2009	K.Okada	CHECK	T.Anzai		APPR.	IFujioka		

5) Click the [Test] button to start testing.

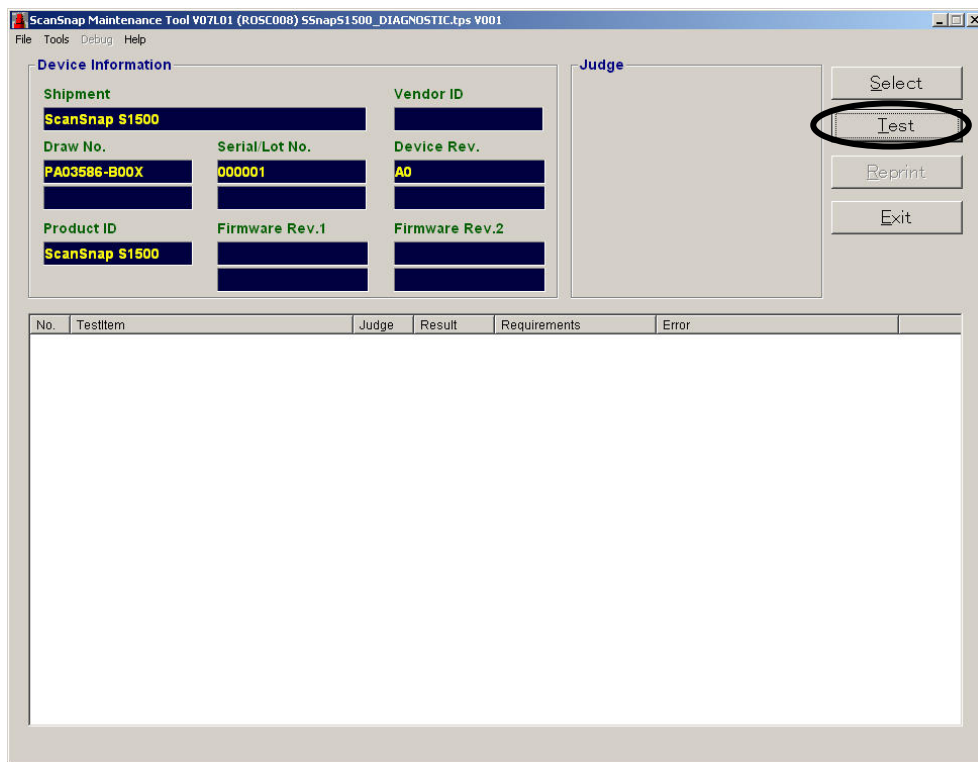

Follow the message on the screen after the procedure above.

Note 1: The screen below appears at image adjustment. Set the specified number and type of test chart. When a sheet of the test chart is scanned, the “Paper empty” error may appear, but you can continue adjustment/diagnosis by resetting the error and setting the next test chart specified in the upper window of the screen.

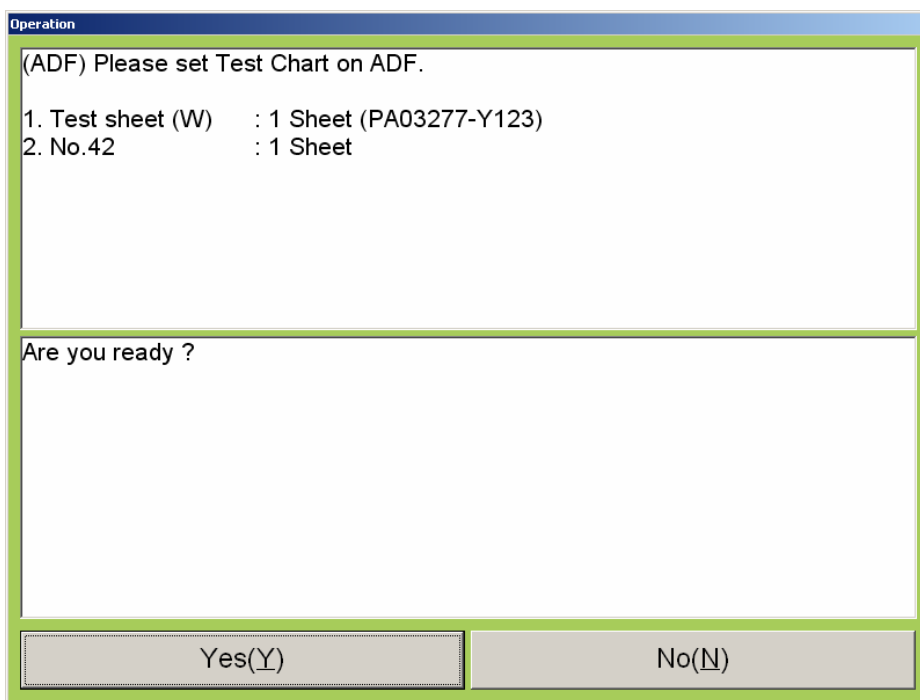

						TITLE	ScanSnap S1500/S1500-SR/S1500M MAINTENANCE MANUAL			
						DRAW. No.	P1PA03586-B00X/6		CUST.	
02	Jan. 23, 2009	K.Okada	T.Anzai	IFujioka	Refer to Revision Record on page 2.					
Rev	DATE	DESIG.	CHECK	APPR.	DESCRIPTION			PFU LIMITED	PAGE	119/140
DESIG	Jan. 9, 2009	K.Okada	CHECK	T.Anzai		APPR.	IFujioka			

- 6) Check the result.
 The result is displayed as shown on steps (7) and (8).
 If any test item fails, a screen similar to the one below appears.

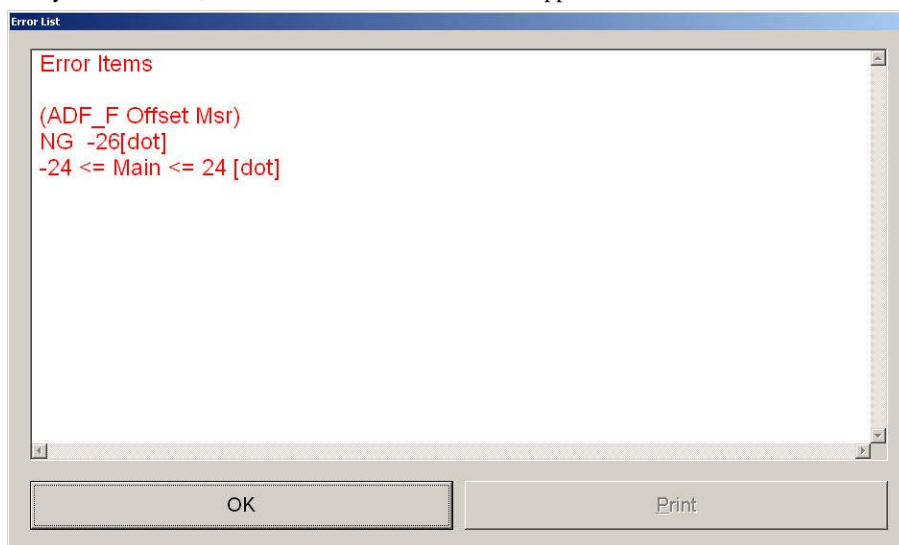

This screen indicates the item names, the results and standards judged NG.
 Click the [OK] button to close this screen.

Refer to the following table to troubleshoot the error.

Error	Table to refer
ADF_F Main Offset	Table 4.3.5
ADF_B Main Offset	
ADF_F Offset	
ADF_B Offset	
ADF F Magnif	
ADF B Magnif	
ADF white level	Table 4.3.6

The NG report is also saved in CSV file. The file is saved in the same file folder where the TP-TOWER is located;

- **Image Quality Test**
 ¥ QC_Data¥ ScanSnap S1500¥ SSnapS1500_DIAGNOSTIC_#####_yyyymmdd_hhmmss_NG
 ¥ QC_Data¥ ScanSnap S1500M¥ SSnapS1500M_DIAGNOSTIC_#####_yyyymmdd_hhmmss_NG
- **Image Quality Adjustment**
 ¥ QC_Data¥ ScanSnap S1500¥ SSnapS1500_ADJUSTMENT_#####_yyyymmdd_hhmmss_NG
 ¥ QC_Data¥ ScanSnap S1500M¥ SSnapS1500M_ADJUSTMENT_#####_yyyymmdd_hhmmss_NG
- **File name: NGReport.csv**
 ##### : Serial No. (Serial number entered on step (4))
 yyyymmdd : Tested date
 hhmmss : Tested time

						TITLE	ScanSnap S1500/S1500-SR/S1500M MAINTENANCE MANUAL			
						DRAW. No.	P1PA03586-B00X/6		CUST.	
02	Jan. 23, 2009	K.Okada	T.Anzai	IFujioka	Refer to Revision Record on page 2.					
Rev	DATE	DESIG.	CHECK	APPR.	DESCRIPTION				PFU LIMITED	PAGE 120/140
DESIG	Jan. 9, 2009	K.Okada	CHECK	T.Anzai		APPR.	IFujioka			

This file folder also contains the image scanned in testing the NG item.

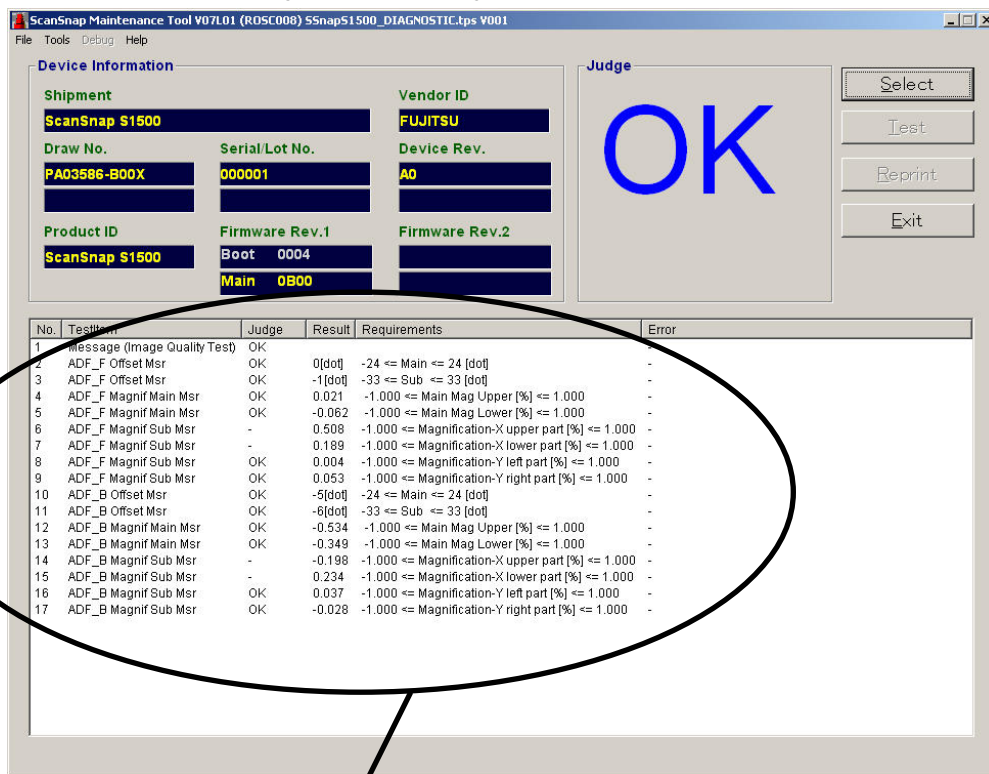

The contents of the display are just an example.

No.	Test Item	Judge	Result	Requirements	Error
1	Message (Image Quality Test)	OK			-
2	ADF_F Offset Msr	OK	0[dot]	-24 <= Main <= 24 [dot]	-
3	ADF_F Offset Msr	OK	-1[dot]	-33 <= Sub <= 33 [dot]	-
4	ADF_F Magnif Main Msr	OK	0.021	-1.000 <= Main Mag Upper [%] <= 1.000	-
5	ADF_F Magnif Main Msr	OK	-0.062	-1.000 <= Main Mag Lower [%] <= 1.000	-
6	ADF_F Magnif Sub Msr	-	0.508	-1.000 <= Magnification-X upper part [%] <= 1.000	-
7	ADF_F Magnif Sub Msr	-	0.189	-1.000 <= Magnification-X lower part [%] <= 1.000	-
8	ADF_F Magnif Sub Msr	OK	0.004	-1.000 <= Magnification-Y left part [%] <= 1.000	-
9	ADF_F Magnif Sub Msr	OK	0.053	-1.000 <= Magnification-Y right part [%] <= 1.000	-
10	ADF_B Offset Msr	OK	-5[dot]	-24 <= Main <= 24 [dot]	-
11	ADF_B Offset Msr	OK	-6[dot]	-33 <= Sub <= 33 [dot]	-
12	ADF_B Magnif Main Msr	OK	-0.534	-1.000 <= Main Mag Upper [%] <= 1.000	-
13	ADF_B Magnif Main Msr	OK	-0.349	-1.000 <= Main Mag Lower [%] <= 1.000	-
14	ADF_B Magnif Sub Msr	-	-0.198	-1.000 <= Magnification-X upper part [%] <= 1.000	-
15	ADF_B Magnif Sub Msr	-	0.234	-1.000 <= Magnification-X lower part [%] <= 1.000	-
16	ADF_B Magnif Sub Msr	OK	0.037	-1.000 <= Magnification-Y left part [%] <= 1.000	-
17	ADF_B Magnif Sub Msr	OK	-0.028	-1.000 <= Magnification-Y right part [%] <= 1.000	-

Front side offset measurement (No.2, 3)

- Test item: ADF_F Offset Msr
- Purpose: To confirm that main & sub-scanning offset values are within specification range.
- How to see the result
- Plus: Image shifted to right compared to the reference point.
- Minus: Image shifted to left compared to the reference point.

Front side magnification measurement (No.4 ~ 9)

- Test item: ADF_F Magnif Main Msr / ADF_F Magnif Sub Msr
- Purpose: To confirm that main & sub-scanning magnification values are within specification range.
- How to see the result
- Plus: Image size is larger than physical size of the chart.
- Minus: Image size is smaller than physical size of the chart.

Backside offset measurement (No.10, 11)

- Test item: ADF_B Offset Msr

Backside magnification measurement (No.12 ~ 17)

- Test item: ADF_B Magnif Main Msr / ADF_B Magnif Sub Msr

						TITLE	ScanSnap S1500/S1500-SR/S1500M MAINTENANCE MANUAL		
						DRAW. No.	P1PA03586-B00X/6	CUST.	
02	Jan. 23, 2009	K.Okada	T.Anzai	IFujioka	Refer to Revision Record on page 2.	PFU LIMITED			PAGE 121/140
Rev	DATE	DESIG.	CHECK	APPR.	DESCRIPTION				
DESIG	Jan. 9, 2009	K.Okada	CHECK	T.Anzai	APPR.	IFujioka			

Device Information

Shipment: ScanSnap S1500
 Vendor ID: FUJITSU
 Draw No.: PA03586-B00X
 Serial/Lot No.: 000001
 Device Rev.: A0
 Product ID: ScanSnap S1500
 Firmware Rev.1: Boot 0004
 Firmware Rev.2: Main 0000

Judge

OK

No.	Test Item	Judge	Result	Requirements	Error
1	EEPROM Initial Setting	OK	OK	---	-
2	Message (Adj Image Quality)	OK			-
3	ADF White Level ADJ Color	OK	Adj 206.47 Msr 247.84	241 < R (Front) Gradation < 251	-
4	ADF White Level ADJ Color	OK	Adj 190.83 Msr 248.62	241 < G (Front) Gradation < 251	-
5	ADF White Level ADJ Color	OK	Adj 186.25 Msr 248.77	241 < B (Front) Gradation < 251	-
6	ADF White Level ADJ Color	OK	Adj 178.62 Msr 245.73	241 < R (Back) Gradation < 251	-
7	ADF White Level ADJ Color	OK	Adj 165.23 Msr 245.68	241 < G (Back) Gradation < 251	-
8	ADF White Level ADJ Color	OK	Adj 161.20 Msr 246.64	241 < B (Back) Gradation < 251	-
9	ADF_F Offset Adj	OK	Adr 0x02 Val 0x8C(-12)	-72 <= Main offset <= +72	-
10	ADF_F Offset Adj	OK	Adr 0x03 Val 0x0C(12)	-127 <= Sub offset <= +127	-
11	ADF_F Magnif Adj	OK	Mag 0.10% Adr 0x0C Val 0x11	-2.5 <= Main Mag <= +1.5	-
12	ADF_F Magnif Adj	OK	Mag 0.22% Adr 0x0A Val 0x14	-3.0 <= Sub Mag <= +3.0	-
13	ADF_B Offset Adj	OK	Adr 0x07 Val 0x87(-7)	-72 <= Main offset <= +72	-
14	ADF_B Offset Adj	OK	Adr 0x08 Val 0x07(7)	-127 <= Sub offset <= +127	-
15	ADF_B Magnif Adj	OK	Mag -0.35% Adr 0x0E Val 0x04	-2.5 <= Main Mag <= +1.5	-
16	ADF_F Optimize Magnif Main	OK	Val:0x11->0x00	Adr:0x0C(0x00-0x04->0x00 0x10-0x14->0x00)	-
17	ADF_B Optimize Magnif Main	OK	Val:0x04->0x00	Adr:0x0E(0x00-0x04->0x00 0x10-0x14->0x00)	-
18	Thermistor Check and Setting	OK	42	10 <= Thermister Val <= 79	-
19	Thermistor Check and Setting	OK	Adr 0x09 Val 0x2A(42)	Thermister Value Write OK	-
20	EEPROM Final Setting	OK	OK	---	-

* The contents of the display are just an example.

No.	Test Item	Judge	Result	Requirements	Error
1	EEPROM Initial Setting	OK	OK	---	-
2	Message (Adj Image Quality)	OK			-
3	ADF White Level ADJ Color	OK	Adj 206.47 Msr 247.84	241 < R (Front) Gradation < 251	-
4	ADF White Level ADJ Color	OK	Adj 190.83 Msr 248.62	241 < G (Front) Gradation < 251	-
5	ADF White Level ADJ Color	OK	Adj 186.25 Msr 248.77	241 < B (Front) Gradation < 251	-
6	ADF White Level ADJ Color	OK	Adj 178.62 Msr 245.73	241 < R (Back) Gradation < 251	-
7	ADF White Level ADJ Color	OK	Adj 165.23 Msr 245.68	241 < G (Back) Gradation < 251	-
8	ADF White Level ADJ Color	OK	Adj 161.20 Msr 246.64	241 < B (Back) Gradation < 251	-
9	ADF_F Offset Adj	OK	Adr 0x02 Val 0x8C(-12)	-72 <= Main offset <= +72	-
10	ADF_F Offset Adj	OK	Adr 0x03 Val 0x0C(12)	-127 <= Sub offset <= +127	-
11	ADF_F Magnif Adj	OK	Mag 0.10% Adr 0x0C Val 0x11	-2.5 <= Main Mag <= +1.5	-
12	ADF_F Magnif Adj	OK	Mag 0.22% Adr 0x0A Val 0x14	-3.0 <= Sub Mag <= +3.0	-
13	ADF_B Offset Adj	OK	Adr 0x07 Val 0x87(-7)	-72 <= Main offset <= +72	-
14	ADF_B Offset Adj	OK	Adr 0x08 Val 0x07(7)	-127 <= Sub offset <= +127	-
15	ADF_B Magnif Adj	OK	Mag -0.35% Adr 0x0E Val 0x04	-2.5 <= Main Mag <= +1.5	-
16	ADF_F Optimize Magnif Main	OK	Val:0x11->0x00	Adr:0x0C(0x00-0x04->0x00 0x10-0x14->0x00)	-
17	ADF_B Optimize Magnif Main	OK	Val:0x04->0x00	Adr:0x0E(0x00-0x04->0x00 0x10-0x14->0x00)	-
18	Thermistor Check and Setting	OK	42	10 <= Thermister Val <= 79	-
19	Thermistor Check and Setting	OK	Adr 0x09 Val 0x2A(42)	Thermister Value Write OK	-
20	EEPROM Final Setting	OK	OK	---	-

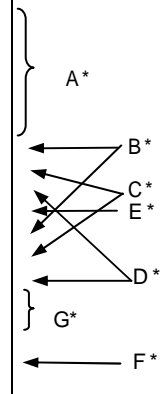

* See next page.

						TITLE	ScanSnap S1500/S1500-SR/S1500M MAINTENANCE MANUAL			
						DRAW. No.	P1PA03586-B00X/6	CUST.		
02	Jan. 23, 2009	K.Okada	T.Anzai	IFujioka	Refer to Revision Record on page 2.					
Rev	DATE	DESIG.	CHECK	APPR.	DESCRIPTION		PFU LIMITED		PAGE	122/140
DESIG	Jan. 9, 2009	K.Okada	CHECK	T.Anzai	APPR.	IFujioka				

- A White level adjustment (No.3~9)
 -Test item: ADF White Level Adj Color
 -Purpose: To adjust the white level balance to correct the image contrast.
 To check the image quality after adjustment.
 -How to see the result:
 "Adj 205.07" → White level before adjustment
 "Msr 248.16" → White level after adjustment
- B Main scanning offset adjustment (No.9, 13)
 -Test item: ADF_F Offset Adj → Front side
 ADF_B Offset Adj → Backside
 -Purpose: To correct the offset in main scanning direction.
 -Ho to see the result:
 "Adr 0x02" → EEPROM address
 "Val:0x8B(-11)" → EEPROM setting value
- C Sub-scanning offset adjustment (No.10, 14)
 -Test item: ADF_F Offset Adj → Front side
 ADF_B Offset Adj → Backside
 -Purpose: To correct the offset in sub-scanning direction.
 -How to see the result:
 "Adr 0x03" → EEPROM address
 "Val 0x0A(10)" → EEPROM setting value
- D Main scanning magnification adjustment (No.11, 15)
 - Test item: ADF_F Magnif Adj → Front side
 ADF_B Magnif Adj → Backside
 -Purpose: To correct the magnification in main scanning direction.
 -How to see the result:
 "Mag 0.09%" → Main scanning magnification before adjustment
 "Adr 0x0C" → EEPROM address
 "Val 0x11" → EEPROM setting value
- E Sub-scanning magnification adjustment (No.12)
 -Test item: ADF_F Magnif Adj → for both Front and Back
 -Purpose: To correct the magnification in sub-scanning direction.
 -How to see the result:
 "Mag 0.19%" → Sub-scanning magnification before adjustment
 "Adr 0x0A" → EEPROM address
 "Val 0x14" → EEPROM setting value
- F Temperature setting at adjustment (No.19)
 -Test item: Temperature measurement and adjustment by thermistor
 -Purpose: To set the temperature in the scanner at sub-scanning magnification adjustment.
 -How to see the result:
 "Mag 0x09" → EEPROM address
 "Val 0x2D(45)" → EEPROM setting value
- G Optimizing main scanning magnification (No.16, 17)
 -Test Item: ADF_F Optimize Magnif Main → Front side
 ADF_B Optimize Magnif Main → Backside
 -Purpose: To correct balance of main scanning magnification and resolution.
 -How to see the result:
 "Val:0x11 -> 0x00" → Last correction value of main scanning magnification

						TITLE	ScanSnap S1500/S1500-SR/S1500M MAINTENANCE MANUAL		
						DRAW. No.	P1PA03586-B00X/6	CUST.	
02	Jan. 23, 2009	K.Okada	T.Anzai	IFujioka	Refer to Revision Record on page 2.				
Rev	DATE	DESIG.	CHECK	APPR.	DESCRIPTION		PFU LIMITED	PAGE	123/140
DESIG	Jan. 9, 2009	K.Okada	CHECK	T.Anzai	APPR.	IFujioka			

Chapter 7 Operation and Daily Maintenance

7.1 Basic Operation

7.1.1 Power ON/OFF

ScanSnap is tuned ON/OFF in conjunction with the connected PC power.

■ Power ON

Open the ADF Paper Chute (cover) of the ScanSnap while the connected PC power is ON.

- ➔ The [Scan] button blinks blue, indicating the ScanSnap is turning on. When the button stops blinking and turns a steady blue, the ScanSnap is ready.

Note: Power Indicator when the ScanSnap is turned ON

When a lot of software is activating on the PC, it may take time until the indicator stops blinking and turns to a steady blue depending on load, performance and environment. If the indicator keeps blinking for a few minutes, close the ADF Paper Chute, and open it again five seconds later. If the indicator does not stop blinking yet, check the cable connection.

■ Power OFF

Turn OFF the connected PC power or close the ADF Paper Chute.

- ➔ The ScanSnap power and the indicator are turned OFF.

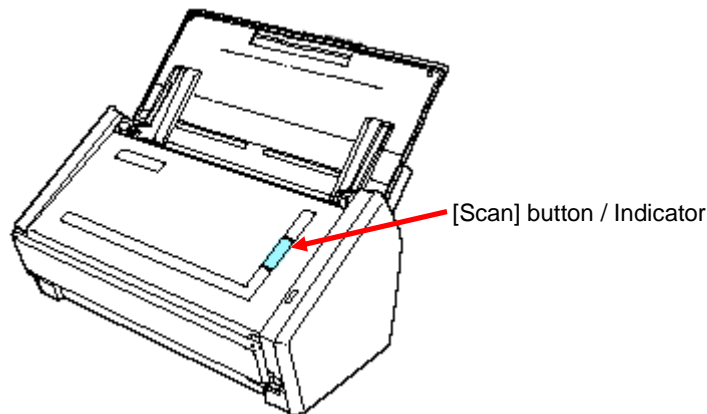

						TITLE	ScanSnap S1500/S1500-SR/S1500M MAINTENANCE MANUAL		
						DRAW. No.	P1PA03586-B00X/6	CUST.	
02	Jan. 23, 2009	K.Okada	T.Anzai	IFujioka	Refer to Revision Record on page 2.				
Rev	DATE	DESIG.	CHECK	APPR.	DESCRIPTION		PFU LIMITED	PAGE	124/140
DESIG	Jan. 9, 2009	K.Okada	CHECK	T.Anzai		APPR. IFujioka			

7.1.2 Opening/Closing the ADF

Follow the procedure below to open the ADF Paper Chute.

- (1) Pull the ADF paper chute release catch and then the Stacker.

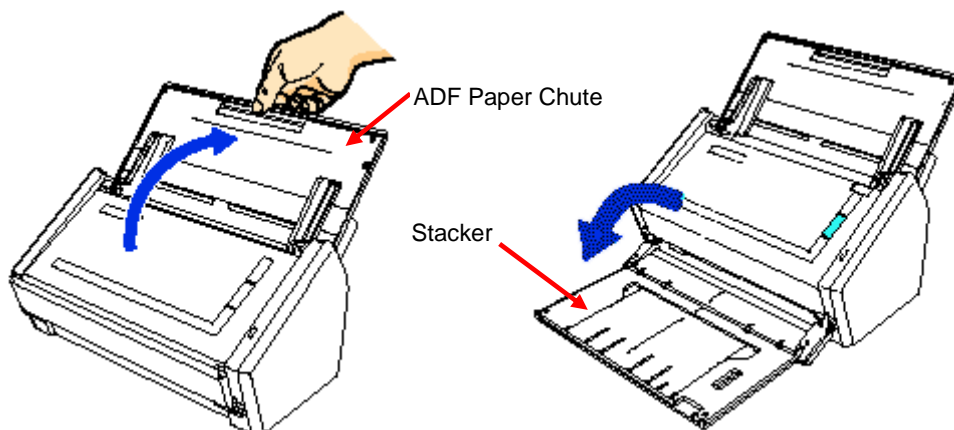

- (2) Pull the ADF release catch to open the ADF top section.

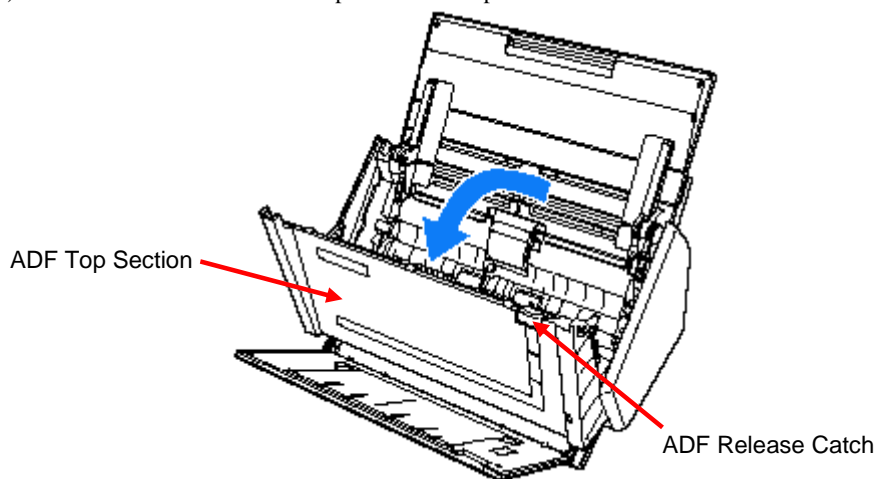

- (3) When closing, follow the procedure above in the reverse order.

NOTICE

You should hear the ADF top section click when it returns to its original position.

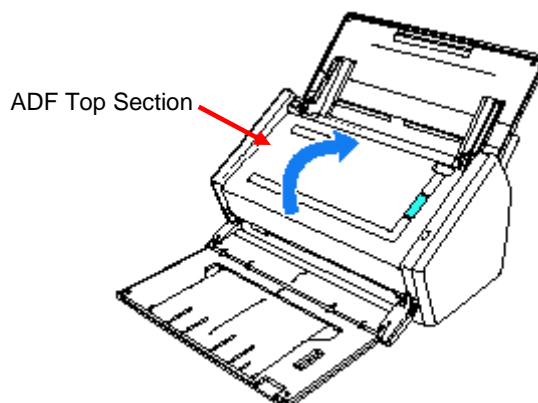

						TITLE	ScanSnap S1500/S1500-SR/S1500M MAINTENANCE MANUAL			
						DRAW. No.	P1PA03586-B00X/6	CUST.		
02	Jan. 23, 2009	K.Okada	T.Anzai	IFujioka	Refer to Revision Record on page 2.		PFU LIMITED		PAGE	125/140
Rev	DATE	DESIG.	CHECK	APPR.	DESCRIPTION					
DESIG	Jan. 9, 2009	K.Okada	CHECK	T.Anzai		APPR.	IFujioka			

7.1.3 Loading Documents

This section describes how to load documents onto the ScanSnap.

- 1) Confirm that ScanSnap Manager icon  is displayed on the taskbar (Windows) or Dock menu (Mac).
- 2) Check the number of sheets in the document stack.
 The maximum number of sheets that can be loaded on the ScanSnap is as follows:
 For A4-size paper or smaller: A document stack of 5 mm or less
 (50 sheets at 80g/m² or at 20lb)
- 3) To prevent paper jams, fan the document.
 1. Hold the document with both hands and fan it out as shown in the figure below.
 2. Turn the document 90 degrees, and then fan it in the different orientation again.

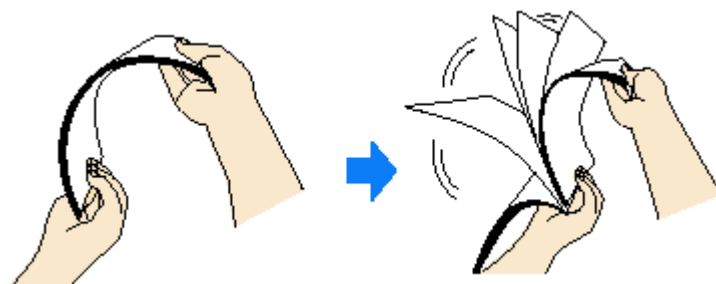

- 4) Straighten the edges of the document, and load it onto the ScanSnap so that the leading edges of the paper form a step-like pattern.

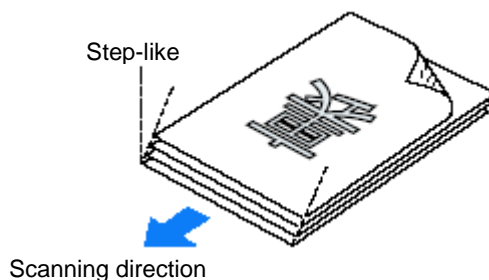

- 5) Open the ADF paper chute of the ScanSnap, and then the Stacker.

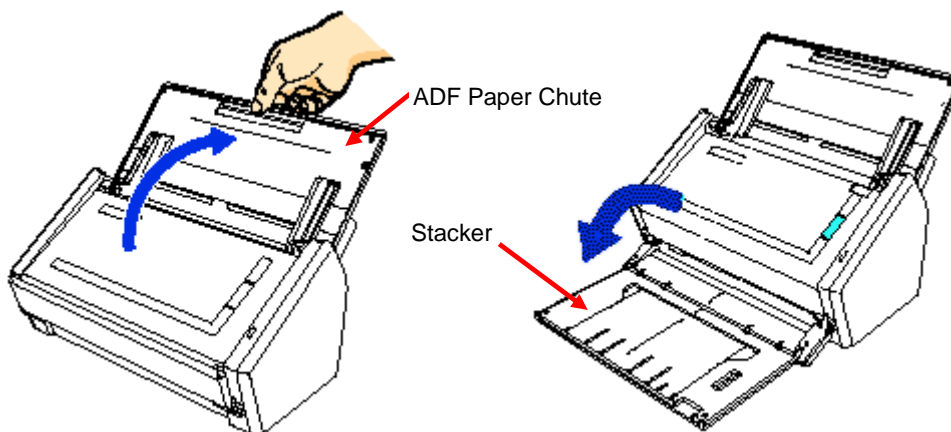

						TITLE	ScanSnap S1500/S1500-SR/S1500M MAINTENANCE MANUAL		
						DRAW. No.	P1PA03586-B00X/6	CUST.	
02	Jan. 23, 2009	K.Okada	T.Anzai	IFujioka	Refer to Revision Record on page 2.				
Rev	DATE	DESIG.	CHECK	APPR.	DESCRIPTION				
DESIG	Jan. 9, 2009	K.Okada	CHECK	T.Anzai		APPR.	IFujioka	PFU LIMITED	PAGE 126/140

6) Pull out the extensions of the ADF Paper Chute and Stacker if necessary (for scanning long length document).

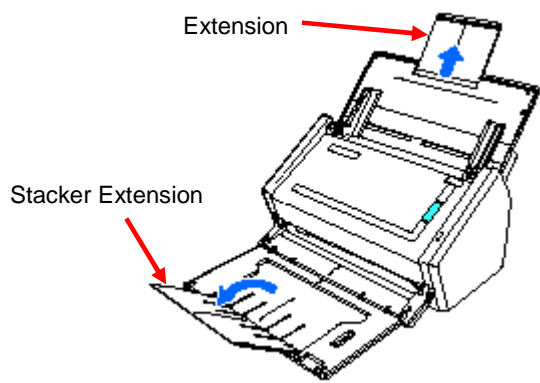

- 7) Load the document onto the paper chute.
- Load the document face-down (so that you are looking at the back of the last page) and leading edge on the ADF Paper Chute.
 - Do not load the document beyond the reference marks on the side guide.

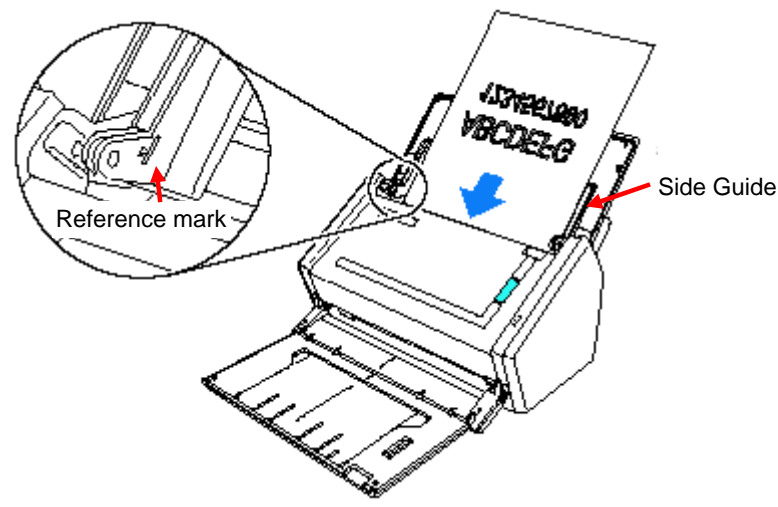

Notes when setting documents on the ADF paper chute:

On Windows, right-click the ScanSnap Manager taskbar icon, select [ScanButton Settings]. In the ScanSnap setup dialog box that appears, click the [Detail] button, select the [Setting] tab, and then click the [Option] button. In the [Read mode option] dialog box, check whether the [Set the documents with its face up] check box is selected. If selected, load the documents face-up and bottom-first.

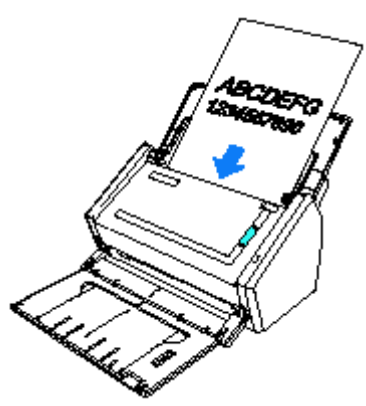

						TITLE	ScanSnap S1500/S1500-SR/S1500M MAINTENANCE MANUAL		
						DRAW. No.	P1PA03586-B00X/6	CUST.	
02	Jan. 23, 2009	K.Okada	T.Anzai	I.Fujioka	Refer to Revision Record on page 2.				
Rev	DATE	DESIG.	CHECK	APPR.	DESCRIPTION				
DESIG	Jan. 9, 2009	K.Okada	CHECK	T.Anzai	APPR.	I.Fujioka	PFU LIMITED		PAGE 127/140

- 8) Adjust the side guides to the document width.
- Move the side guides so that there is no gap between the document edge and side guide on both sides. Doing so eliminates skewing of the document during scanning.

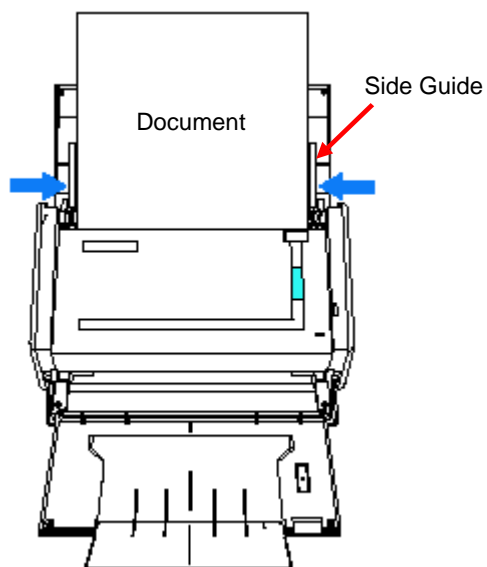

						TITLE	ScanSnap S1500/S1500-SR/S1500M MAINTENANCE MANUAL				
						DRAW. No.	P1PA03586-B00X/6		CUST.		
02	Jan. 23, 2009	K.Okada	T.Anzai	IFujioka	Refer to Revision Record on page 2.						
Rev	DATE	DESIG.	CHECK	APPR.	DESCRIPTION				PFU LIMITED	PAGE	128/140
DESIG	Jan. 9, 2009	K.Okada	CHECK	T.Anzai		APPR.	IFujioka				

7.2. Daily Care

This section describes how to clean the ScanSnap.



- Before you clean the ScanSnap, turn off the ScanSnap and disconnect the power cable from the AC outlet. Not doing so may cause a fire or electric shock.
- To avoid injuries, do not place internal parts such as pad assembly and pick roller in an area where small children may be able to reach them.
- Do not use any aerosol sprays or alcohol based sprays to clean the ScanSnap. Dust blown up by strong air from the spray may enter inside of the ScanSnap. This may cause the ScanSnap to fail, malfunction or scanning errors. Sparks, caused by static electricity, generated when blowing off dust and dirt from the outside of the ScanSnap may cause a fire.

7.2.1 Cleaning Materials

Following is the materials to be used for cleaning the ScanSnap.

- Isopropyl Alcohol
It may take long before the cleaner vaporizes if a large quantity is used. When cleaning the ScanSnap parts, dampen a cloth with modest quantities of the cleaner. In addition, wipe off the cleaner completely with a soft lint-free cloth to leave no residue on the surface of the cleaned parts.
- Cleaning Wipe
Pre-moistened with isopropyl alcohol, cleaning wipes are used instead of moistened cloths.
- Dry cloth
Any lint-free cloth can be used.

For the purchase of the consumables, contact the FUJITSU scanner dealer where you purchased your scanner.

7.2.2 Cleaning the ScanSnap Exterior

Clean the ScanSnap exterior and the Stacker with a dry cloth or a cloth moistened with neutral detergent or isopropyl alcohol.

- Never use paint thinner and other organic solvents.
- During the cleaning, prevent water or moisture from getting inside the ScanSnap.
- It may take long before the cleaner vaporizes if a large quantity is used. When cleaning the ScanSnap parts, dampen a cloth with modest quantities of the cleaner. In addition, wipe off the cleaner completely with a soft lint-free cloth to leave no residue on the surface of the cleaned parts.

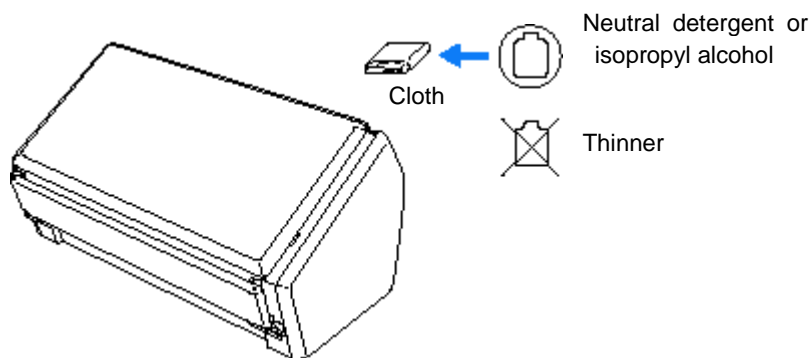

						TITLE	ScanSnap S1500/S1500-SR/S1500M MAINTENANCE MANUAL		
						DRAW. No.	P1PA03586-B00X/6	CUST.	
02	Jan. 23, 2009	K.Okada	T.Anzai	IFujioka	Refer to Revision Record on page 2.				
Rev	DATE	DESIG.	CHECK	APPR.	DESCRIPTION		PFU LIMITED	PAGE	129/140
DESIG	Jan. 9, 2009	K.Okada	CHECK	T.Anzai		APPR. IFujioka			

7.2.3 Cleaning the Inside of the ScanSnap

Clean inside of the ScanSnap with a cloth moistened with isopropyl alcohol.

In an alternating succession of scanning documents, the accumulated paper-powder and dust inside the ScanSnap causes a scanner error.

As a guideline, clean the inside of the ScanSnap every 1,000 scans. Note that this guideline varies according to the type of the documents you are scanning. For example, the inside of the ScanSnap must be cleaned more frequently when scanning documents with loose toner.

Clean the inside of the ScanSnap according to the following procedure.



WARNING

The scan glass surface inside the ADF becomes hot during ScanSnap operation. Before you start to clean the inside of the ScanSnap, disconnect the power cable from the AC outlet and wait at least 15 minutes to let the ScanSnap cool down.

Notes when cleaning:

- Do not use water or neutral detergent to clean the inside of the ScanSnap
- It may take long before the cleaner vaporizes if a large quantity is used. When cleaning the ScanSnap parts, dampen a cloth with modest quantities of the cleaner. In addition, wipe off the cleaner completely with a soft lint-free cloth to leave no residue on the surface of the cleaned parts.

- (1) Open the ADF Paper Chute, and then the Stacker.

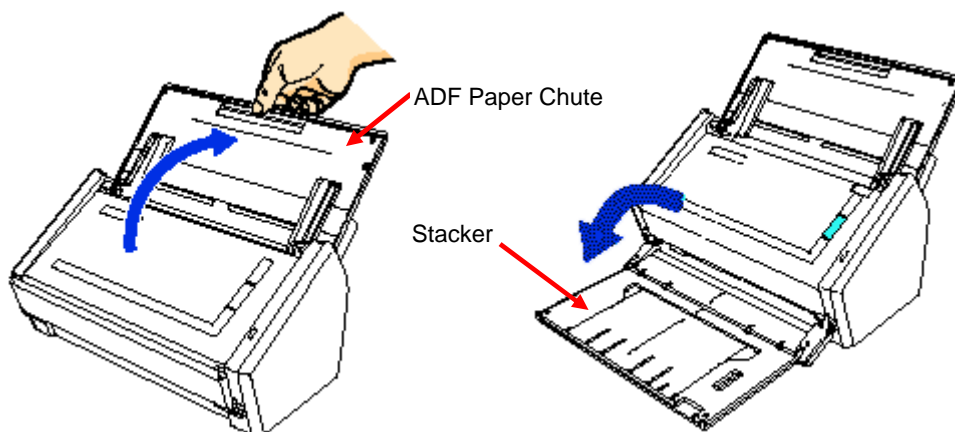

- (2) Pull the ADF Release Catch to open the ADF Top Section, and then open the Stacker.

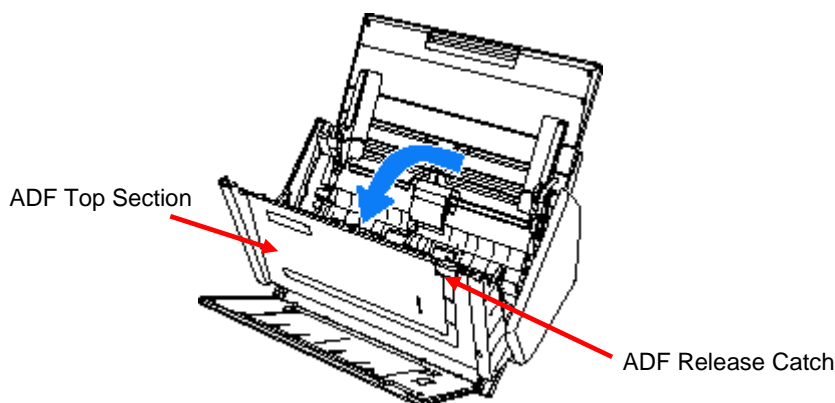

						TITLE	ScanSnap S1500/S1500-SR/S1500M MAINTENANCE MANUAL		
						DRAW. No.	P1PA03586-B00X/6	CUST.	
02	Jan. 23, 2009	K.Okada	T.Anzai	IFujioka	Refer to Revision Record on page 2.				
Rev	DATE	DESIG.	CHECK	APPR.	DESCRIPTION		PFU LIMITED	PAGE	130/140
DESIG	Jan. 9, 2009	K.Okada	CHECK	T.Anzai		APPR.		IFujioka	

(3) Clean the following locations with a cloth moistened with isopropyl alcohol.

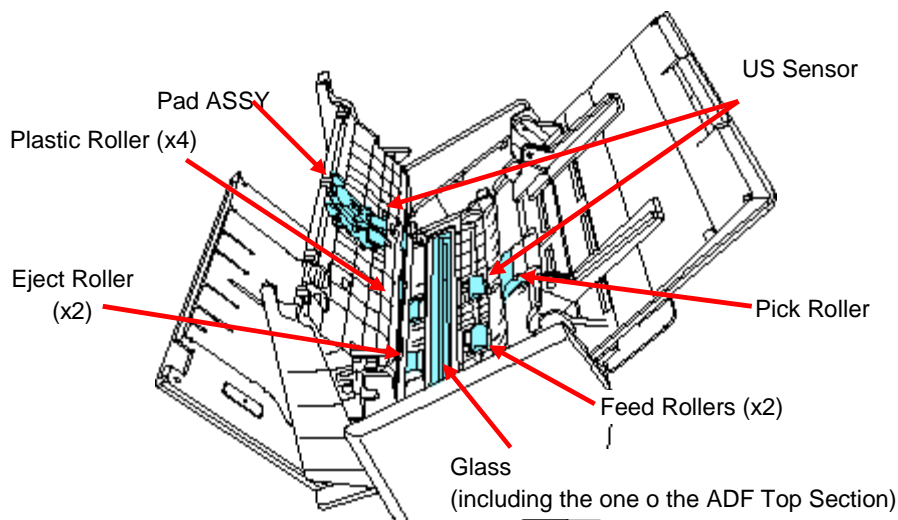

NOTICE

It may take long before the cleaner vaporizes if a large quantity is used. When cleaning the ScanSnap parts, dampen a cloth with modest quantities of the cleaner. In addition, wipe off the cleaner completely with a soft lint-free cloth to leave no residue on the surface of the cleaned parts.

Turn off the ScanSnap before cleaning the following locations:

Location	Cleaning Method
Pad ASSY (x1)	Wipe the pad assembly downwards. When cleaning the pad ASSY, take care to prevent the cloth from catching on the metal parts.
Scan Glass (x2, located on the ADF Top Section and opposite side)	Clean lightly with a soft cloth.
White Sheets x2, located on the ADF Top Section and opposite side)	White strips along the edge of the scan glass. Clean the surface lightly with a soft cloth.
Pick Roller (x1)	Clean it lightly while rotating the roller with your finger downwards. Be careful not to roughen the surface of the rollers. Take particular care in cleaning the rollers since debris left on the roller adversely affects the feed performance.
Idler Rollers (x4, located on the ADF Top Section)	Clean them lightly while rotating the rollers with your finger. Be careful not to roughen the surface of the rollers. Take particular care in cleaning the rollers since debris left on the roller adversely affects the feed performance.
US Sensor	Clean them lightly on the US Sensor surface.

Turn on the ScanSnap before cleaning the following locations, and clean the rollers while rotating them.

Connect the AC adapter and power cable only when cleaning the feed rollers and exit rollers

Location	Cleaning Method
Feed Rollers (x2)	Clean lightly taking care not to roughen the surface of the rollers. Take particular care in cleaning the rollers since debris left on the roller adversely affects the feed performance.
Exit rollers (x2)	Clean lightly, taking care not to roughen the surface of the rollers. Take particular care when cleaning the exit rollers since debris on these rollers adversely affect the pickup performance. Holding the [Scan] button down for 3 seconds while the ADF Top Section is open activates the cleaning mode. In this mode, every time the [Scan] button is pressed, the feed and exit rollers rotate about 1/6th of a full turn.

						TITLE	ScanSnap S1500/S1500-SR/S1500M MAINTENANCE MANUAL		
						DRAW. No.	P1PA03586-B00X/6	CUST.	
02	Jan. 23, 2009	K.Okada	T.Anzai	IFujioka	Refer to Revision Record on page 2.				
Rev	DATE	DESIG.	CHECK	APPR.	DESCRIPTION				
DESIG	Jan. 9, 2009	K.Okada	CHECK	T.Anzai	APPR.	IFujioka	PFU LIMITED	PAGE	131/140

(4) Close the ADF Top Section, the Stacker, and then the ADF Paper Chute.

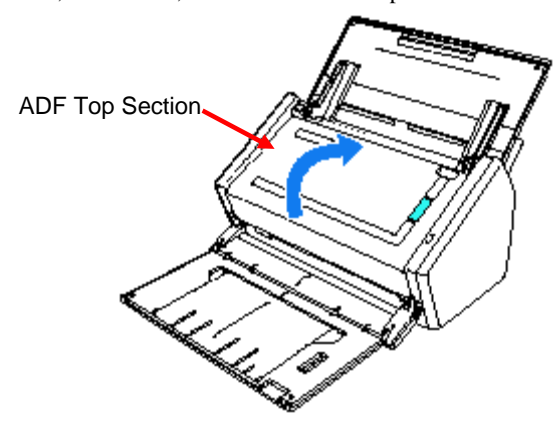

→ You should hear the ADF Top Section click when it returns to its original position.

7.2.4 Cleaning Carrier Sheet

If the Carrier Sheet is used extensively, dirt and dust may stick onto the surface or the interior and cause scanning errors. Clean it regularly to avoid errors.

Use dry, soft cloth, or soft cloth slightly moistened with isopropyl alcohol or mild detergent to lightly clean off the dirt and dust from the surface and the interior of the Carrier Sheet.

Notes when cleaning:

- Never use paint thinner or other organic solvents.
- Do not rub the Carrier Sheet too hard. Otherwise, it may be scratched or be deformed.
- After cleaning the interior of the Carrier Sheet with isopropyl alcohol or mild detergent, dry the Carrier Sheet completely before closing it.
- As a guideline, it is recommended to replace the Carrier Sheet with new one every 500 scans.

						TITLE	ScanSnap S1500/S1500-SR/S1500M MAINTENANCE MANUAL		
						DRAW. No.	P1PA03586-B00X/6	CUST.	
02	Jan. 23, 2009	K.Okada	T.Anzai	IFujioka	Refer to Revision Record on page 2.				
Rev	DATE	DESIG.	CHECK	APPR.	DESCRIPTION				
DESIG	Jan. 9, 2009	K.Okada	CHECK	T.Anzai		APPR.	IFujioka	PFU LIMITED	

7.3 Consumables and Replacement

This chapter describes how to replace consumables.



WARNING

- Before you replace the consumables, turn off the ScanSnap and disconnect the power cable from the AC outlet. Not doing so may cause a fire or electric shock.
- To avoid injuries, do not place internal parts such as pad assembly and pick roller in an area where small children may be able to reach them.

7.3.1 Consumables

The ScanSnap has the following consumables that users need to replace at the following regular intervals.

To check the number of scanned documents, go to [ScanSnap Manager] – [Check consumable supplies...].

No.	Part name	Specifications	Standard replacement cycle *	How to check the number of scanned documents	How to replace
1	Pick roller	PA03586-0001	100,000 sheets or one year	See Sections 7.3.2, 7.3.3.	See Section 7.3.4.
2	Pad ASSY	PA03586-0002	50,000 sheets or one year		See Section 7.3.5.

These replacement cycles are rough guidelines for the case of using A4/Letter wood-free paper 80 g/m² (20 lb). So it may differ according to the paper being used.

For the purchase of the consumables, contact the FUJITSU scanner dealer where you purchased your scanner.

						TITLE	ScanSnap S1500/S1500-SR/S1500M MAINTENANCE MANUAL		
						DRAW. No.	P1PA03586-B00X/6		CUST.
02	Jan. 23, 2009	K.Okada	T.Anzai	IFujioka	Refer to Revision Record on page 2.				
Rev	DATE	DESIG.	CHECK	APPR.	DESCRIPTION	PFU LIMITED		PAGE	133/140
DESIG	Jan. 9, 2009	K.Okada	CHECK	T.Anzai		APPR.	IFujioka		

7.3.2 Confirming and Resetting the Consumable Counter [Windows]

By the following procedure, check how many sheets have been scanned using the consumables.

- (1) Select [Check consumable supplies] from the Right-Click Menu on ScanSnap Manager.

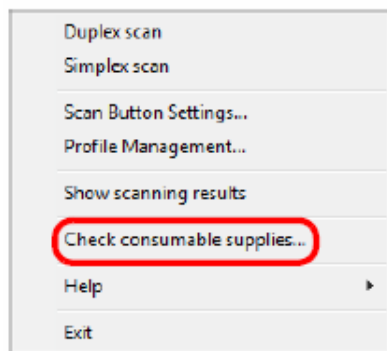

→ The [ScanSnap Manager - Check consumable status] dialog box appears.

- (2) Check how many times consumables have been used.

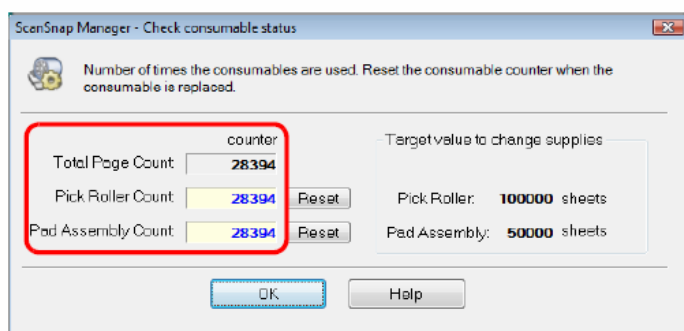

→ Replace consumables referring to [Target value to change supplies] as a rough guideline.

- (3) After replacing the consumables, click the [Reset] button for the replaced consumable. When the confirmation message appears, click the [Yes] button.

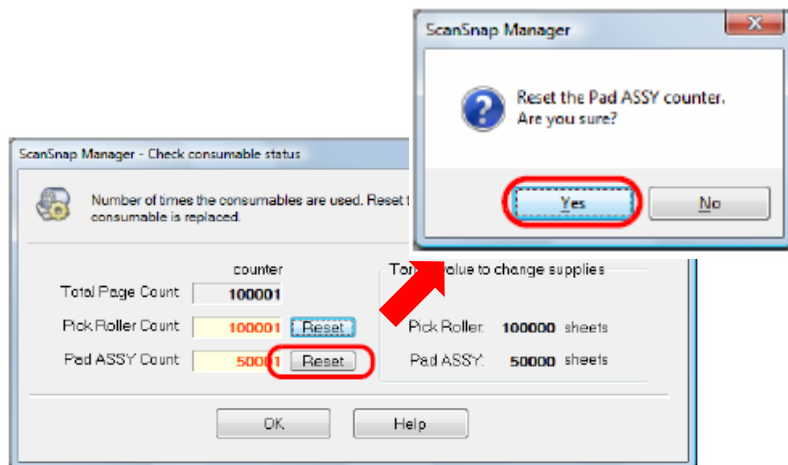

- (4) When the counter is reset, consumable replacement is complete.
Note: Once the counter is cleared, it cannot be restored.

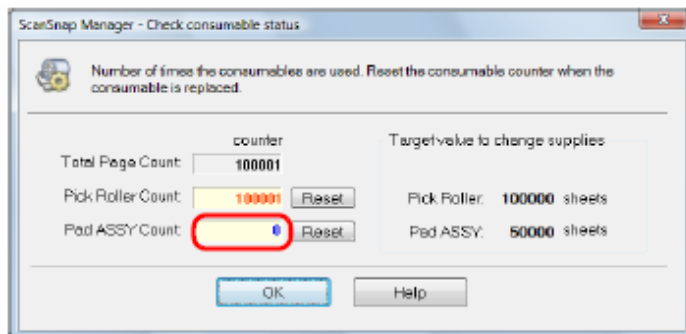

						TITLE	ScanSnap S1500/S1500-SR/S1500M MAINTENANCE MANUAL		
						DRAW. No.	P1PA03586-B00X/6		CUST.
02	Jan. 23, 2009	K.Okada	T.Anzai	IFujioka	Refer to Revision Record on page 2.				
Rev	DATE	DESIG.	CHECK	APPR.	DESCRIPTION				
DESIG	Jan. 9, 2009	K.Okada	CHECK	T.Anzai		APPR.	IFujioka	PFU LIMITED	PAGE 134/140

7.3.3 Confirming and Resetting the Consumable Counter [Mac]

By the following procedure, check how many sheets have been scanned using the consumables.

- (1) Select [Check consumable supplies] from the ScanSnap Manager menu.

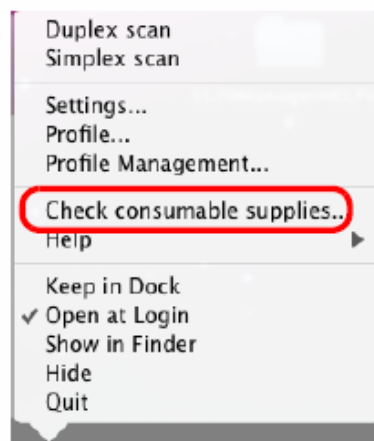

→ The [ScanSnap Manager - Check consumable status] dialog box appears.

- (2) Check how many times consumables have been used.

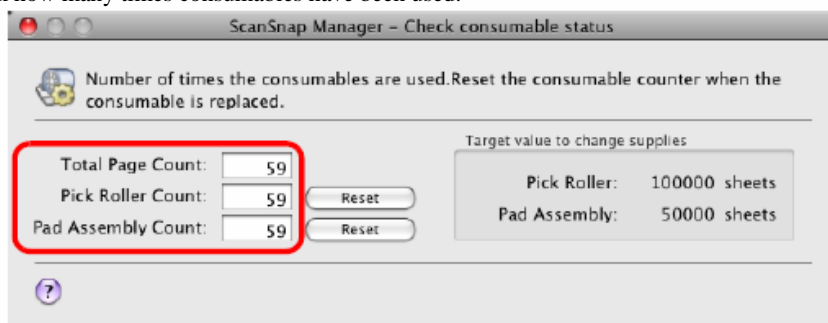

→ Replace consumables referring to [Target value to change supplies] as a rough guideline.

- (3) After replacing the consumables, click the [Reset] button for the replaced consumable. When the confirmation message appears, click the [Yes] button.

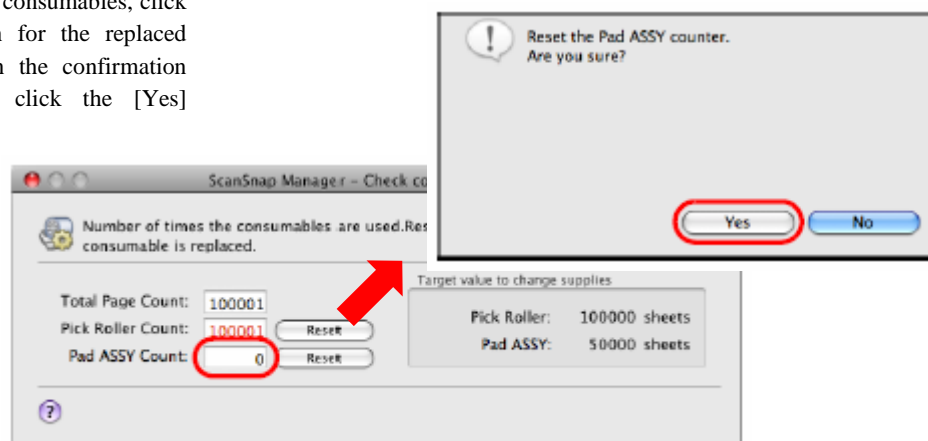

- (4) When the counter is reset, consumable replacement is complete.
Note: Once the counter is cleared, it cannot be restored.

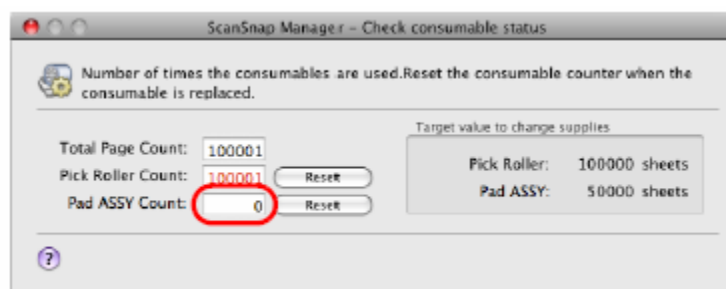

						TITLE	ScanSnap S1500/S1500-SR/S1500M MAINTENANCE MANUAL		
						DRAW. No.	P1PA03586-B00X/6	CUST.	
02	Jan. 23, 2009	K.Okada	T.Anzai	IFujioka	Refer to Revision Record on page 2.				
Rev	DATE	DESIG.	CHECK	APPR.	DESCRIPTION			PFU LIMITED	PAGE 135/140
DESIG	Jan. 9, 2009	K.Okada	CHECK	T.Anzai		APPR.	IFujioka		

7.3.4 Replacing the Pick Roller

Replace the Pick roller in the following procedure.

- (1) Remove the documents on the ADF Paper Chute.
- (2) Pull the ADF Release Catch to open the ADF Top Section.

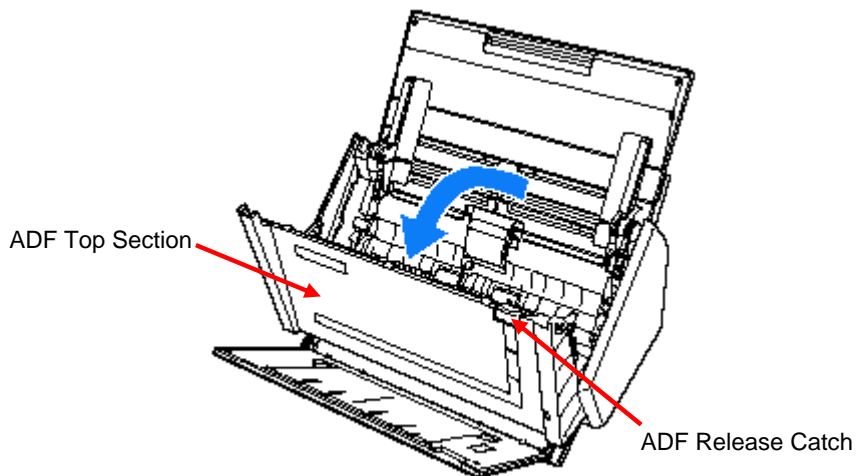

- (3) Adjust the side guide to the "A5" size.

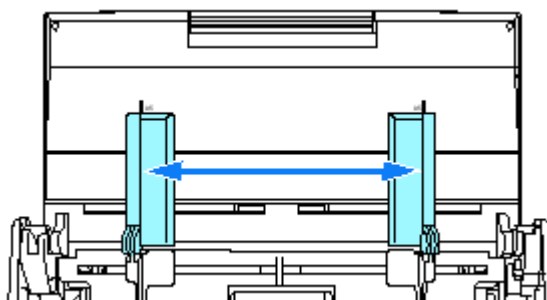

- (4) Hold the pickup tabs on the Guide P ASSY between the thumb and index fingers, and then pull up the Guide P ASSY to remove.

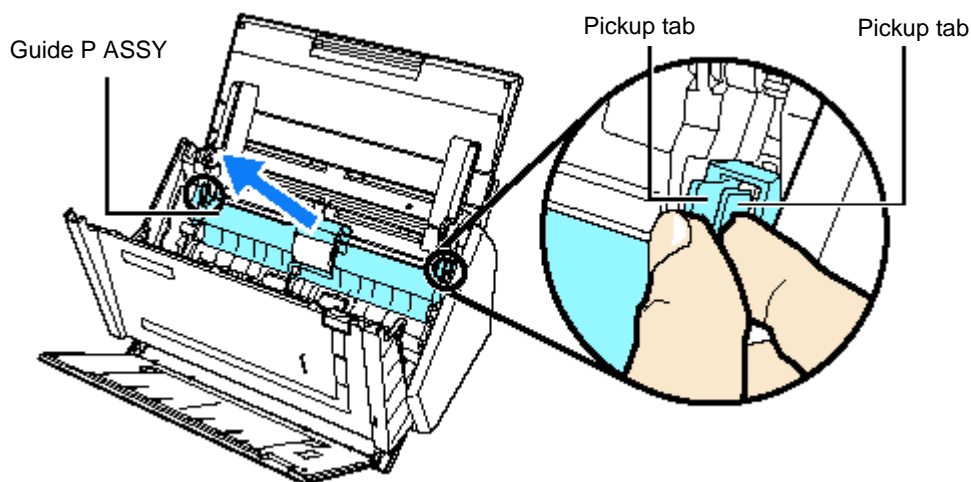

						TITLE	ScanSnap S1500/S1500-SR/S1500M MAINTENANCE MANUAL		
						DRAW. No.	P1PA03586-B00X/6	CUST.	
02	Jan. 23, 2009	K.Okada	T.Anzai	IFujioka	Refer to Revision Record on page 2.				
Rev	DATE	DESIG.	CHECK	APPR.	DESCRIPTION				
DESIG	Jan. 9, 2009	K.Okada	CHECK	T.Anzai	APPR.	IFujioka	PFU LIMITED		PAGE 136/140

(5) Rotate the bushing (left) of the Pick Shaft ASSY.

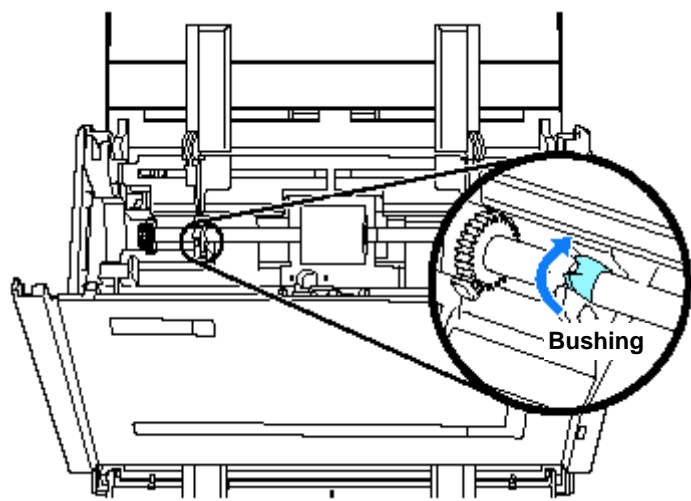

(6) Slightly pull up the left part of the Pick roller shaft, move it towards the left side (1), and then raise it (2) to remove from the ScanSnap.

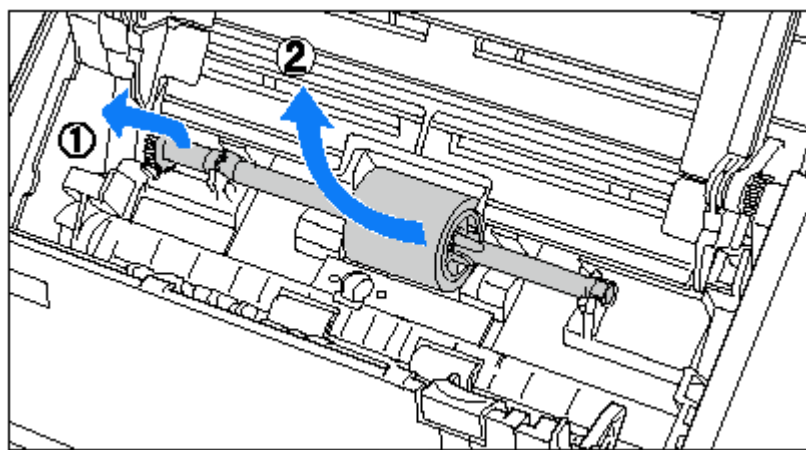

Notes:

If the area around the Pick roller is dirty by paper-powder, it may cause a scanning error.
 Remove the dirt using a dry cloth slightly moistened with isopropyl alcohol in order to prevent errors.
 Do NOT use water, mild detergent or air-spray.

						TITLE	ScanSnap S1500/S1500-SR/S1500M MAINTENANCE MANUAL		
						DRAW. No.	P1PA03586-B00X/6	CUST.	
02	Jan. 23, 2009	K.Okada	T.Anzai	IFujioka	Refer to Revision Record on page 2.				
Rev	DATE	DESIG.	CHECK	APPR.	DESCRIPTION		PFU LIMITED	PAGE	137/140
DESIG	Jan. 9, 2009	K.Okada	CHECK	T.Anzai	APPR.	IFujioka			

(7) Pull out the shaft from the Pick roller while lifting up its tab.

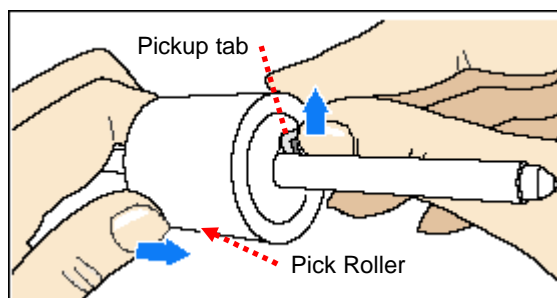

Note: If you push up the Pick roller tab using your fingernail, your fingernail may be hurt or get chipped.
 If you cannot push it up successfully with your fingernail, use a paper clip to push up the Pick roller tab.

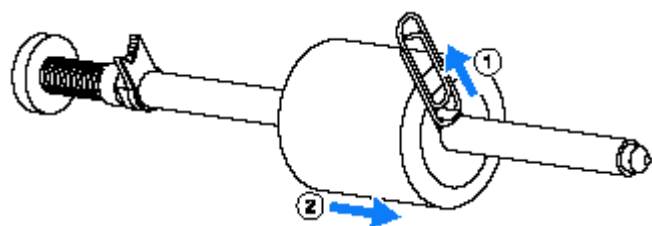

(8) Insert the shaft aligning the protrusion with the slot on the new Pick roller.

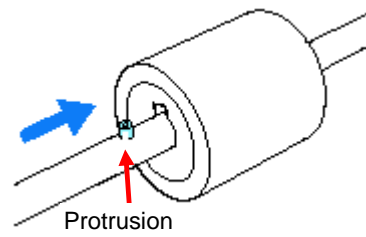

(9) Insert the top of the Pick Roller shaft into the right of the roller bushing, and set the shaft into the slot while lowering it.

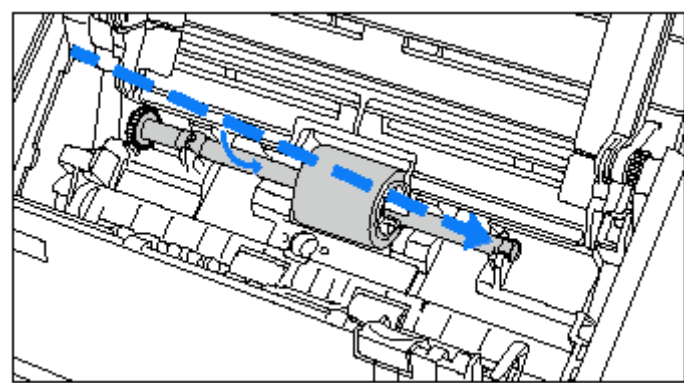

						TITLE	ScanSnap S1500/S1500-SR/S1500M MAINTENANCE MANUAL		
						DRAW. No.	P1PA03586-B00X/6	CUST.	
02	Jan. 23, 2009	K.Okada	T.Anzai	IFujioka	Refer to Revision Record on page 2.				
Rev	DATE	DESIG.	CHECK	APPR.	DESCRIPTION				
DESIG	Jan. 9, 2009	K.Okada	CHECK	T.Anzai	APPR.	IFujioka	PFU LIMITED		PAGE 138/140

(10) Secure the bushing (left) by rotating it in the direction of the arrow.

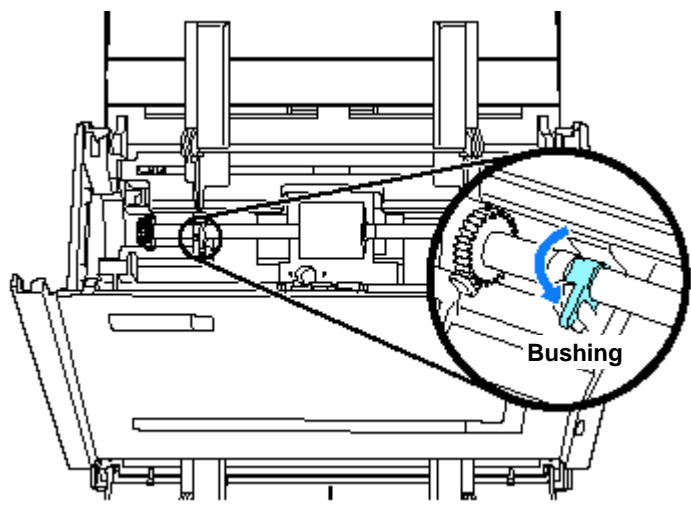

Note: Make sure that the Pick roller is completely attached. Otherwise document jams or other feeding errors may occur.

(11) Hold the pickup tabs on the Guide P ASSY between the thumb and index finger, and then attach the Guide P ASSY to the ScanSnap.

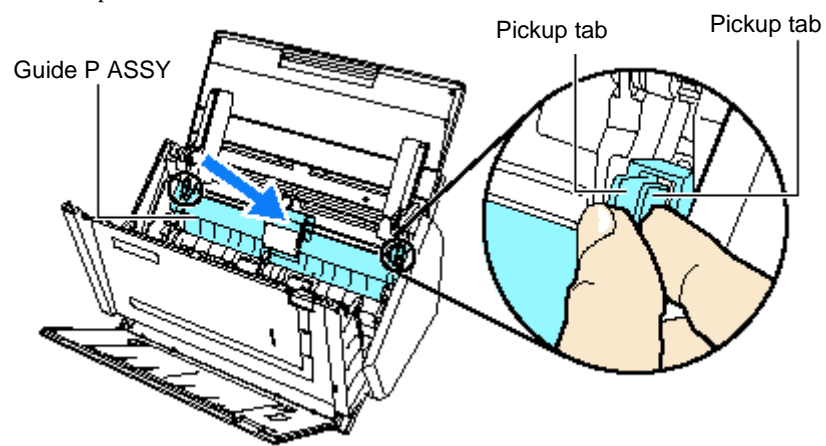

→ The Guide P ASSY makes a clicking sound when the pickup tabs fix into position.

Note: Make sure that the Guide P ASSY is completely attached. Otherwise document jams or other feeding errors may occur.

(12) Close the ADF Top Section.

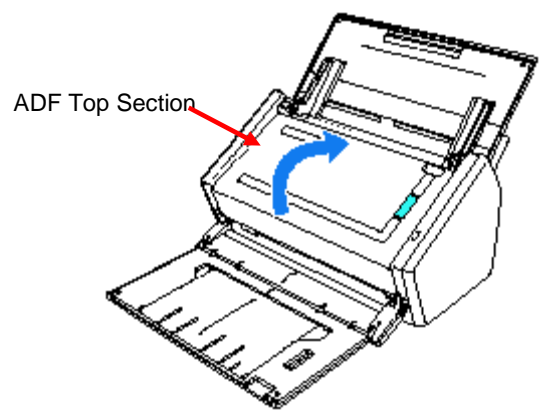

→ You should hear the ADF Top Section click when it returns to its original position.

						TITLE	ScanSnap S1500/S1500-SR/S1500M MAINTENANCE MANUAL		
						DRAW. No.	P1PA03586-B00X/6	CUST.	
02	Jan. 23, 2009	K.Okada	T.Anzai	IFujioka	Refer to Revision Record on page 2.				
Rev	DATE	DESIG.	CHECK	APPR.	DESCRIPTION				
DESIG	Jan. 9, 2009	K.Okada	CHECK	T.Anzai	APPR.	IFujioka	PFU LIMITED		PAGE 139/140

7.3.5 Replacing the Pad ASSY

Replace the Pad ASSY in the following procedure.

- (1) Remove the documents on the ADF Paper Chute.
- (2) Pull the ADF Release Catch to open the ADF Top Section.

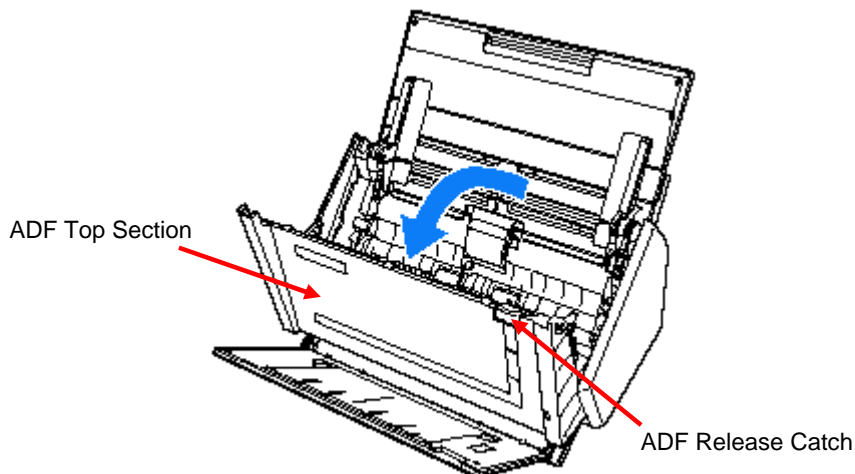

- (3) Pull out the Pad ASSY in the direction of the arrow while pinching both ends of the Pad ASSY.

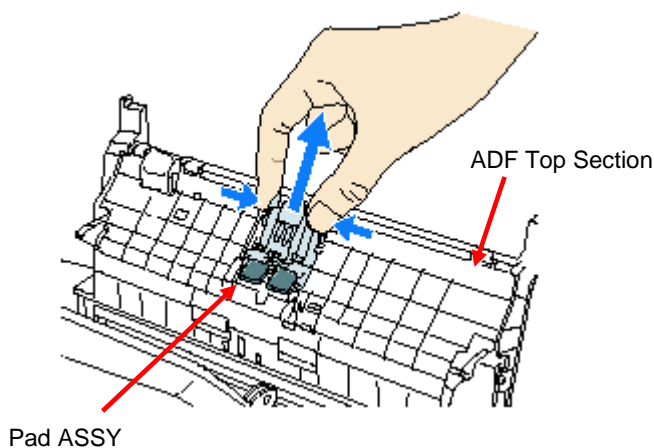

- (4) Attach the new Pad ASSY in the reverse order of removal.

Note: Make sure that the pad assembly is completely attached. Otherwise, document jams or other feeding errors may occur.

- (5) Close the ADF Top Section.

→ You should hear the ADF Top Section click when it returns to its original position.

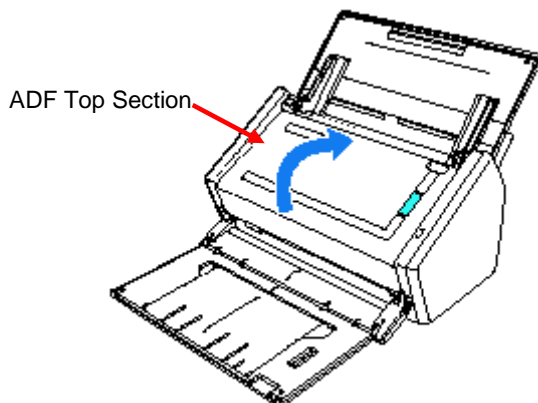

						TITLE	ScanSnap S1500/S1500-SR/S1500M MAINTENANCE MANUAL		
						DRAW. No.	P1PA03586-B00X/6	CUST.	
02	Jan. 23, 2009	K.Okada	T.Anzai	IFujioka	Refer to Revision Record on page 2.				
Rev	DATE	DESIG.	CHECK	APPR.	DESCRIPTION				
DESIG	Jan. 9, 2009	K.Okada	CHECK	T.Anzai	APPR.	IFujioka	PFU LIMITED		PAGE 140/140